

PARTS MANUAL



Mikasa SERIES
MODEL MVH408GH
REVERSIBLE PLATE COMPACTOR
(HONDA GX390UT2SMXC/GX390UT2SMC
GASOLINE ENGINES)

Revision #10 (04/01/21)

THIS MANUAL MUST ACCOMPANY THE EQUIPMENT AT ALL TIMES.

SUGGESTED SPARE PARTS

MVH408GH PLATE COMPACTOR

1 to 3 units

Qty.	P/N	Description
4	939010010	SHOCK ABSORB, STOPPER
4	939010260	SHOCK ABSORBER
2	070200453	V-BELT B-45
1	956100069	THROTTLE WIRE

NOTICE

Part numbers on this Suggested Spare Parts list may supersede/replace the part numbers shown in the following parts lists.

HONDA GX390UT2SMXC/GX390UT2SCM ENGINES

1 to 3 units

Qty.	P/N	Description
3	0650140480	SPARK PLUG
1	28462ZE3W01	ROPE, RECOIL STARTER
3◆	17210ZE3505	AIR CLEANER ELEMENT
3◇	17210Z1C781	AIR CLEANER ELEMENT
1◆	17218ZE3505	FILTER, OUTER
1◇	17218Z1C780	FILTER, OUTER
1	17620Z4H900	FUEL TANK CAP COMP.
2	17672Z4H000	FILTER, FUEL

NOTICE

- ◆ GX390UT2SMXC
- ◇ GX390UT2SCM

NAMEPLATE AND DECALS ASSY.

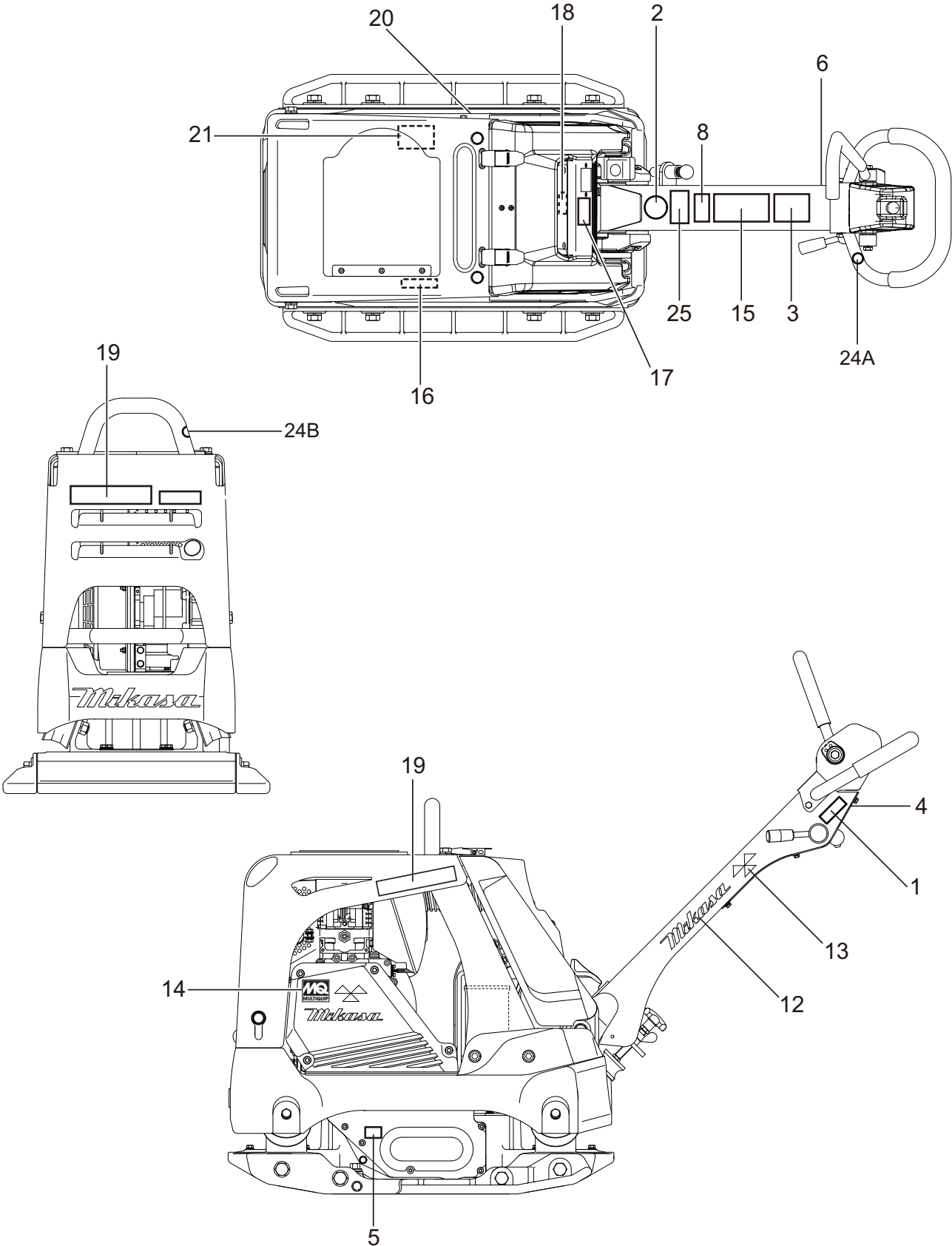

NAMEPLATE AND DECALS ASSY.

<u>NO.</u>	<u>PART NO.</u>	<u>PART NAME</u>	<u>QTY.</u>	<u>REMARKS</u>
1	920204580	DECAL: FULL THROTTLE	1	
2	920203330	EAR PROTECTION LABEL	1	
3	920211060	DECAL: CAUTION (LEVER)	1	
4	920211090	DECAL: SHELL TELLUS OIL 32	1	
5	920201950	DECAL: OIL SAE 10W-30	1	
6	920106760	DECAL: STOP-RUN-START	1	
8	920214100	DECAL: E/G FIRE WARNING	1	
12	920217130	DECAL: MIKASA MARK (W) 200L	2	
13	920217110	DECAL: MIKASA MARK 35X70	2	
14	920201580	DECAL: MQ MARK 71X55	1	
15	920218390	DECAL: CAUTION	1	
16	920205860	DECAL: V-BELT	1	
17	920218160	DECAL: E/G RPM 3200	1	
18	920217880	DECAL: MODEL	1	
19	920217770	DECAL: MODEL (R, OR)	2	
20	920217780	DECAL: MODEL (L, OR)	1	
21		PLATE: SERIAL NO.	1CONTACT MQ PARTS DEPT.
24A	920900090	DECAL, SET, DO NOT LIFT	1	
24B	920900090	DECAL, SET, LIFTING POSITION	1	
25	920222240	DECAL, WARNING PROPOSITION 65	1	

VIBRATING PLATE ASSY.

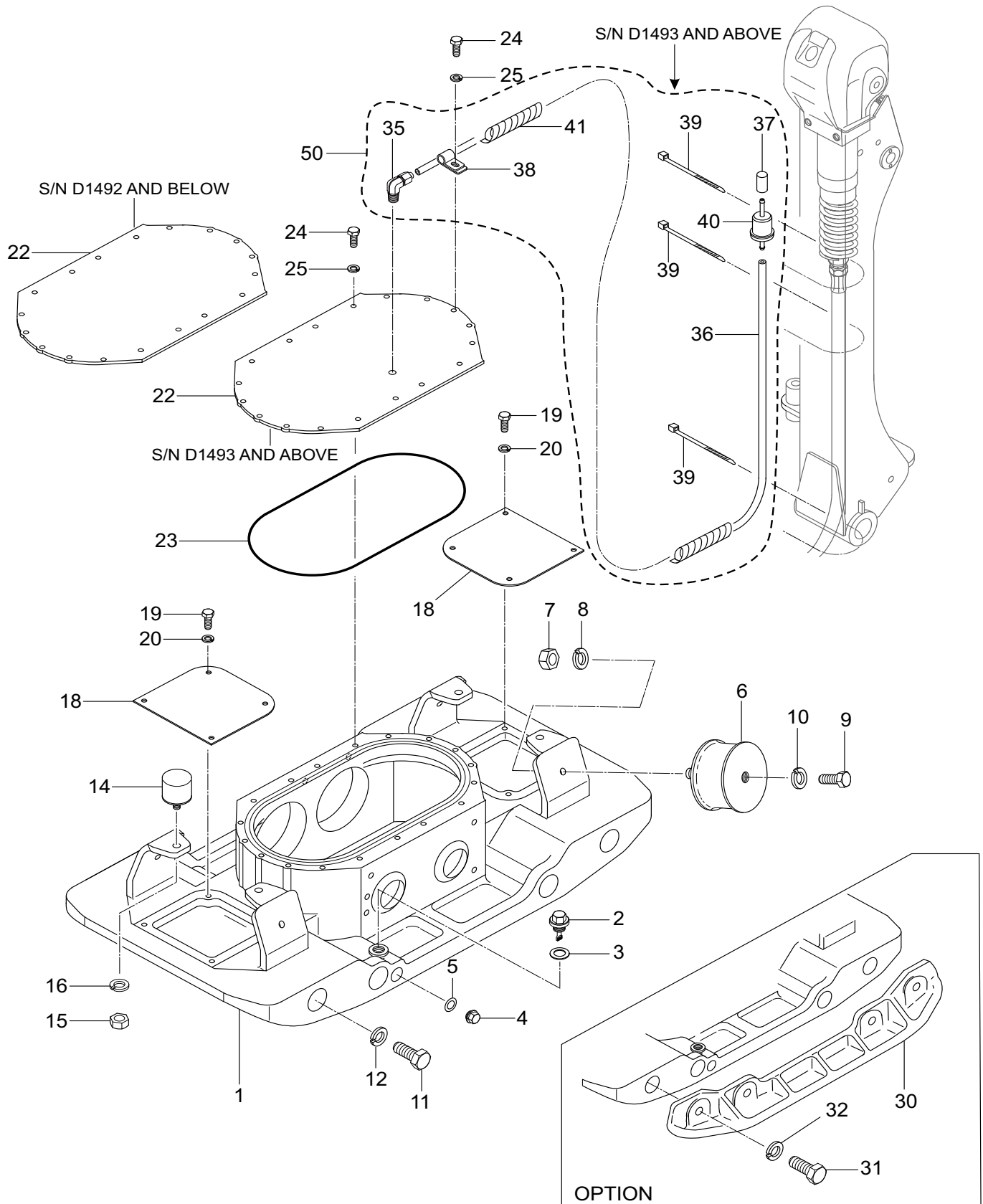

VIBRATING PLATE ASSY.

<u>NO.</u>	<u>PART NO.</u>	<u>PART NAME</u>	<u>QTY.</u>	<u>REMARKS</u>
1	468121201	VIBRATING PLATE	1	
2	465460670	OIL GAUGE	1	
3	953402930	COPPER PACKING 19X30X1	1	
4	953400270	PLUG 1/4X14 10L	1	
5	953405260	PACKING 1/4 (CU)	1	
6	939010260	SHOCK ABSORBER 110X60H	4	
7	020316130	NUT M16	4	
8	030216400	WASHER, LOCK M16	4	
9	001221635	BOLT 16X35	4	
10	030216400	WASHER, LOCK M16	4	
11	001221830	BOLT 18X30	8	
12	58407	WASHER, LOCK M18	8.....	REPLACES P/N 030218460
14	939010010	SHOCK ABSORBER, STOPPER	4	
15	020310080	NUT M10	4	
16	030210250	WASHER, LOCK M10	4	
18	468352110	COVER, VIBRATING PLATE	2	
19	014208020	BOLT 8X20	8.....	REPLACES P/N 001220820
20	030208200	WASHER, LOCK M8	8	
22	467351790	COVER, VIBRATOR	1.....	S/N 1492 AND BELOW
22	467355940	COVER, VIBRATOR, BREATHER	1.....	S/N 1493 AND ABOVE
23	050103250	O-RING G-325	1	
24	014208020	BOLT 8X20	18.....	REPLACES P/N 001220820
25	030208200	WASHER, LOCK M8	18	
30	467219050	EXTENSION PLATE	2	
31	012218050	BOLT 18X50	8.....	REPLACES P/N 001221850
32	58407	WASHER, LOCK M18	8.....	REPLACES P/N 030218460
35#	954410070	90° ELBOW.....	1.....	S/N 1493 AND ABOVE
36#	959029209	TUBE, NYLON 6X8X1000	1.....	S/N 1493 AND ABOVE
37#	467471710	ELEMENT, BREATHER	1.....	S/N 1493 AND ABOVE
38#	959408920	CLIP, M8.....	1.....	S/N 1493 AND ABOVE
39#	507010110	CLAMP.....	3.....	S/N 1493 AND ABOVE
40#	16910GB2005	FUEL FILTER, IN-LINE	1.....	S/N 1493 AND ABOVE
41#	959021818	SPRIAL TUBE.....	1.....	S/N 1493 AND ABOVE
50	467910040	AIR BREATHER TUBE	1.....	INCLUDES ITEMS W/#

VIBRATOR ASSY.

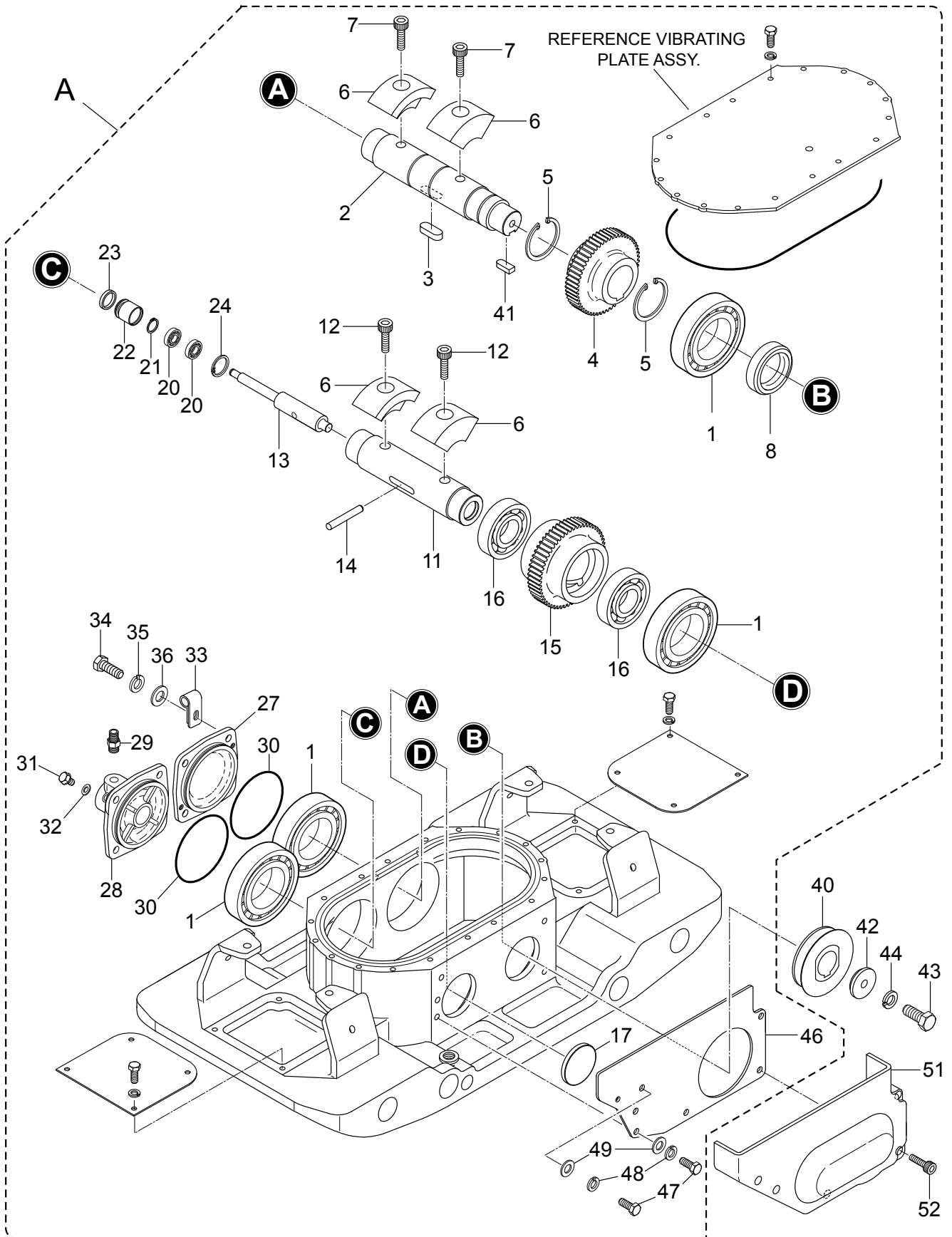

VIBRATOR ASSY.

<u>NO.</u>	<u>PART NO.</u>	<u>PART NAME</u>	<u>QTY.</u>	<u>REMARKS</u>
A	468910040	VIBRATING PLATE ASSY. (OLD)	1.....	S/N D1492 AND BELOW INCLUDES ITEMS W/#
A	468910041	VIBRATING PLATE ASSY. (NEW)	1.....	S/N D1493 AND ABOVE INCLUDES ITEMS W/%
1#%	047920120	ROLLER BEARING	4	
2#	457212410	ROTARY SHAFT, DRIVE	1.....	S/N D1492 AND BELOW
2%	467355910	ROTARY SHAFT, DRIVE	1.....	S/N D1493 AND ABOVE
3#%	951405370	KEY 15X10X39	1	
4#%	456327150	GEAR, DRIVE	1	
5#%	080200550	STOP RING	2	
6#%	468352210	ECCENTRIC ROTATOR	4	
7#%	009120301	SOCKET HEAD BOLT 16X40	2	
8#	060105030	OIL SEAL	1.....	S/N D1492 AND BELOW
8%	060405040	OIL SEAL	1.....	S/N D1493 AND ABOVE
11#%	456337670	ROTARY SHAFT, DRIVEN	1	
12#%	009120302	SOCKET HEAD BOLT 16X30	2	
13#%	456337380	PISTON ROD	1	
14#%	456010010	KNOCK PIN 10X70	1	
15#%	467351910	GEAR (DRIVEN)	1	
16#%	040006911	BEARING	2	
17#%	953010030	SEAL CAP	1	
20#%	042506000	BEARING 6000ZZSG	2	
21#%	0080000010	STOP RING	1.....	REPLACES P/N 080200100
22#%	455435051	PISTON	1	
23#%	455010070	PACKING VSH-22.4X30X5	1	
24#%	080100260	STOP RING	1	
27#%	467352540	BEARING COVER	1	
28#%	467219070	CYLINDER (R)	1	
29#%	954010020	CONNECTOR PT, PF1/4	1	
30#%	050101050	O-RING	2	
31#%	001720812	FLANGE BOLT8X12	1	
32#%	953404600	COPPER PACKING	1	
33#%	959408880	CLIP 15 (M10)	1	
34#%	0105091025	BOLT 10X25	8.....	REPLACES P/N 001221025
35#%	030210250	WASHER, LOCK M10	8	
36#%	031110160	WASHER, FLAT M10	8	
40	465345090	PULLEY	1	
41#%	951404970	KEY 12X8X30 R	1	
42	456437920	WASHER, PULLEY	1	
43	012212035	BOLT 12X35	1.....	REPLACES P/N 001221235
44	030212300	WASHER, LOCK M12	1	
46#%	467351920	GUIDE, BELT COVER	1	
47#%	014208020	BOLT 8X20	2.....	REPLACES P/N 001220820
48#%	030208200	WASHER, LOCK M8	2	
49#%	0401450080	WASHER, FLAT M8	2.....	REPLACES P/N 031108160
51	468218960	BELT COVER, LOWER	1	
52	001520856	SOCKET HEAD BOLT 8X80	5	

BASE AND ENGINE ASSY.

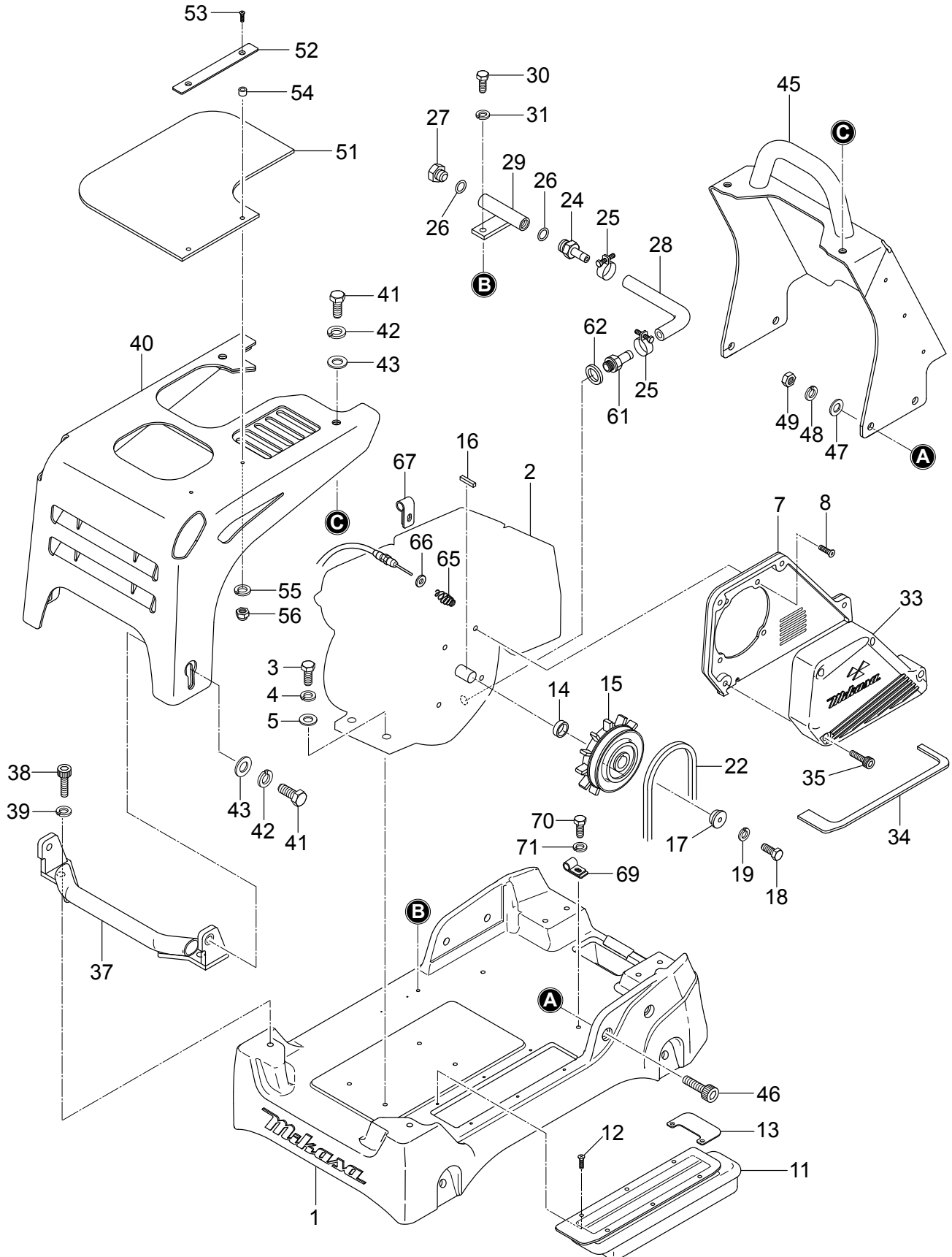

BASE AND ENGINE ASSY.

<u>NO.</u>	<u>PART NO.</u>	<u>PART NAME</u>	<u>QTY.</u>	<u>REMARKS</u>
1	468121260	BASE L100	1	
2	912239016	ENGINE ASSY., GX390UT2SMXC.....	1	S/N C1147 ~ BELOW
2	912239022	ENGINE ASSY., GX390UT2SCM.....	1	S/N C1148 ~ ABOVE
3	0105051045	BOLT 10X45	4	REPLACES P/N 001221045
4	030210250	WASHER, LOCK M10	4	
5	031110160	WASHER, FLAT M10	4	
7	468352240	BELT COVER, IN	1	
8	009110071	SOCKET HEAD BOLT 10X25	4	
11	468352120	DUST COVER	1	
12	092006010	FLAT HEAD SCREW 6X10	6	
13	468467050	PLATE, BELT COVER	1	
14	952408810	SPACER 25X31.8X10	1	
15	456343340	CLUTCH ASSY.	1	
16	951400110	KEY 7X7X35	1	
17	952406050	SPECIAL WASHER	1	
18	011208030	BOLT 8X30	1	REPLACES P/N 001220830
19	030208200	WASHER, LOCK M8	1	
22	070200453	V-BELT B-45	1	
24	954407310	UNION, DRAIN	1	
25	0091720000	HOSE CLAMP	2	
26	0211140020	GASKET	2	
27	0401140030	PLUG	1	
28	465459390	DRAIN HOSE	1	
29	464457380	DRAIN JOINT	1	
30	014208020	BOLT 8X20	1	REPLACES P/N 001220820
31	030208200	WASHER, LOCK M8	1	
33	467121100	BELT COVER (OUT)	1	
34	467351800	DUST SPONGE (OUT)	2	
35	001521054	SOCKET HEAD BOLT 10X70	4	
37	468352140	FRONT BUMPER	1	
38	001521435	SOCKET HEAD BOLT 14X35	2	
39	030214350	WASHER, LOCK M14	2	
40	468121230	FRONT COVER	1	

BASE AND ENGINE ASSY. (CONT'D.)

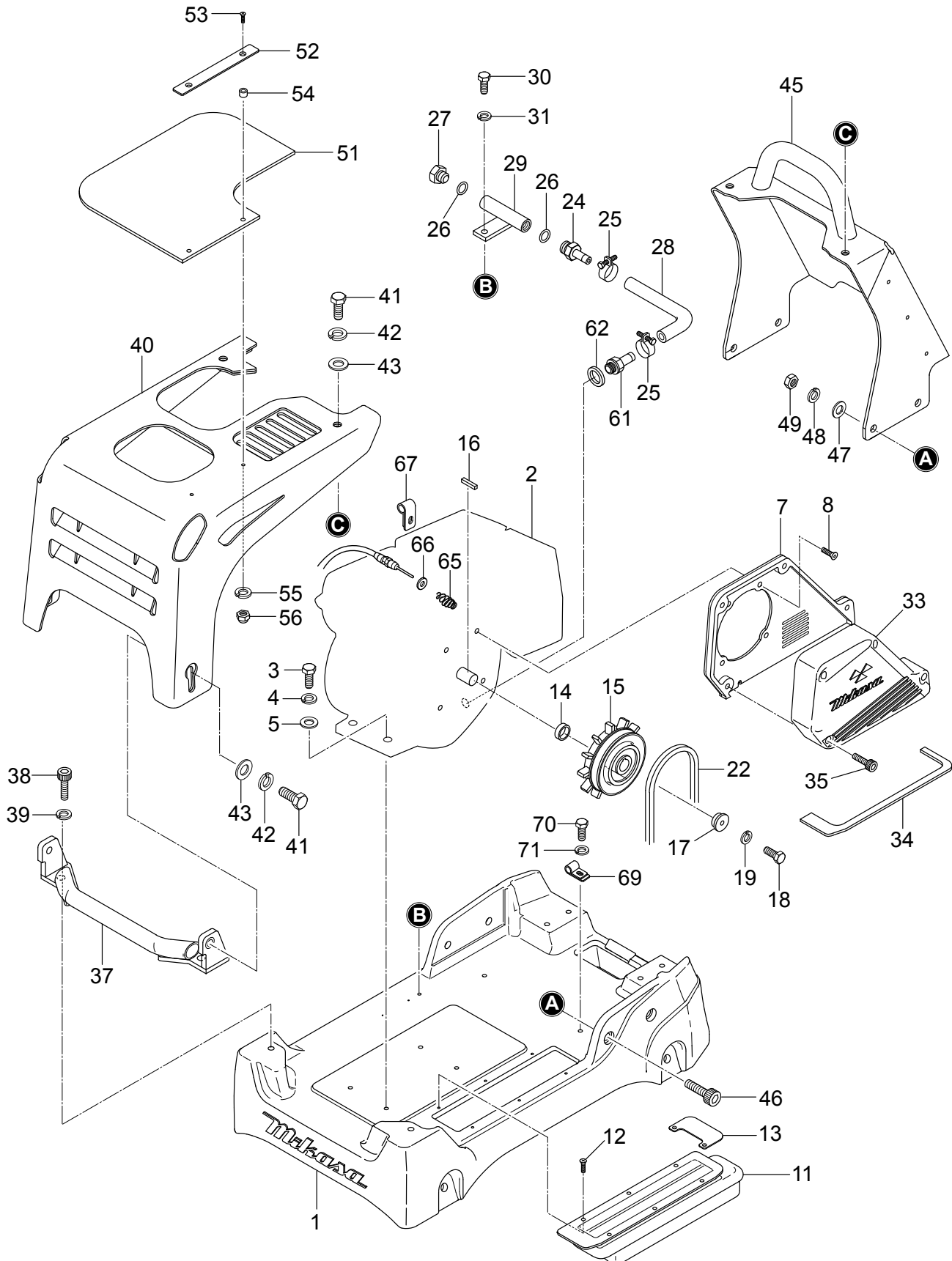

BASE AND ENGINE ASSY. (CONT'D.)

<u>NO.</u>	<u>PART NO.</u>	<u>PART NAME</u>	<u>QTY.</u>	<u>REMARKS</u>
41	001221445	BOLT 14X45	4	
42	030214350	WASHER, LOCK M14	4	
43	031114260	WASHER, FLAT M14	4	
45	468121240	CENTER COVER	1	
46	001521435	SOCKET HEAD BOLT 14X35	4	
47	031114260	WASHER, FLAT M14	4	
48	030214350	WASHER, LOCK M14	4	
49	020314110	NUT M14	4	
51	467466800	RUBBER COVER, UPPER	1	
52	467466810	STOPPER, COVER	1	
53	009120424	SOCKET HEAD BOLT 6X25	2	
54	617465130	COLLAR 6.2X7.8X4.5	2	
55	030206150	WASHER, LOCK M6	2	
56	022710607	NYLON NUT M6	2	
61	90131ZE3790	DRAIN JOINT	1	
62	031112230	WASHER, DRAIN PLUG M12	1.....	REPLACES P/N 9410912000
65	402010110	COIL SPRING	1.....	REPLACES P/N 0830000010
66	58151	WASHER, FLAT M5	1.....	REPLACES P/N 031105080
67	2067550101	CLAMP COMPLETE	1	
69	959407260	CLIP D6 (FOR M10)	1	
70	012210015	BOLT 10X15	1.....	REPLACES P/N 001221015
71	030210250	WASHER, LOCK M10	1	

ELECTRIC DEVICE ASSY.

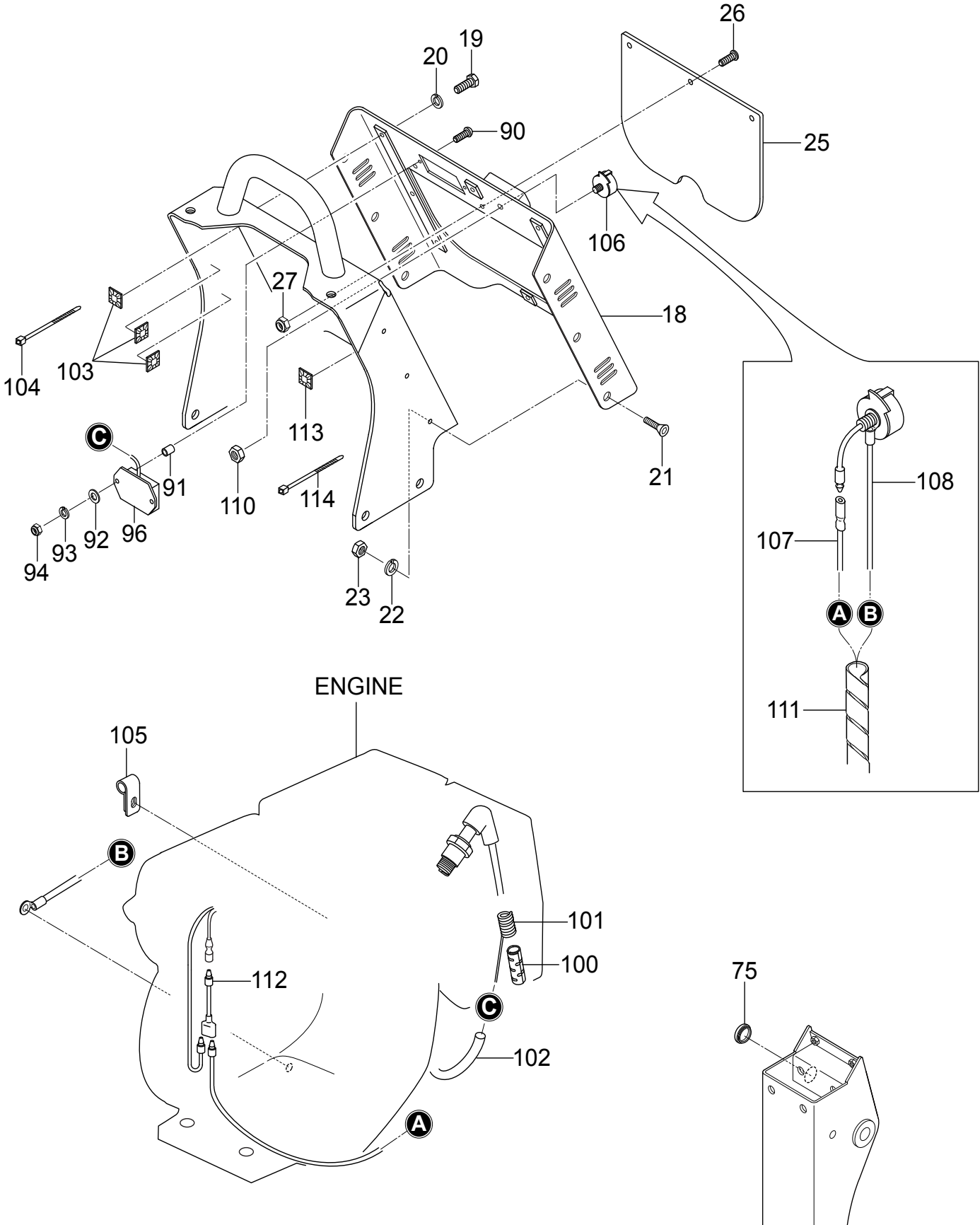

ELECTRIC DEVICE ASSY.

<u>NO.</u>	<u>PART NO.</u>	<u>PART NAME</u>	<u>QTY.</u>	<u>REMARKS</u>
18	468218970	REAR COVER	1	
19	011006010	BOLT 6X10	8	REPLACES P/N 001220610
20	030206150	WASHER, LOCK M6	8	
21	009120413	SUNK HEAD BOLT 6X15	6	
22	030206150	WASHER, LOCK M6	6	
23	020106050	NUT M6	6	REPLACES P/N 020306050
25	467466950	RUBBER COVER, REAR	1	
26	009110062	SOCKET HEAD SCREW 6X20	3	
27	022710607	NYLON NUT M6	3	
75	515010070	GROMMET	1	
90	009110072	PAN HEAD SCREW 5X35	2	
91	952407930	COLLAR 6X10X13.5	2	
92	58151	WASHER, FLAT M5	2	REPLACES P/N 031105080
93	030205130	WASHER, LOCK M5	2	
94	022710506	NYLON NUT M5	2	
96	955010311	TACH./HOUR METER	1	
100	955010307	CLIP BELT	1	
101	955010308	CURL CORD	1	
102	959026828	RUBBER TUBE L=850	1	
103	955407970	WIRING FIXED BASE	3	
104	454010020	CLAMP TC-100	3	
105	2067550101	CLAMP COMPLETE	1	
106	955301010	STOP SWITCH,ENGINE	1	
107	468467570	READ CORD	1	
108	467466980	LEAD WIRE (SW-GROUND)	1	
110	020108060	NUT M8	1	REPLACES P/N 020308060
111	959021812	SPIRAL TUBE 6D-800L	1	
112	515450380	WIRE HARNESS/MRH-600, 700	1	
113	955407970	WIRING FIXED BASE	3	
114	454010020	CLAMP	3	

CONTROL ASSY.

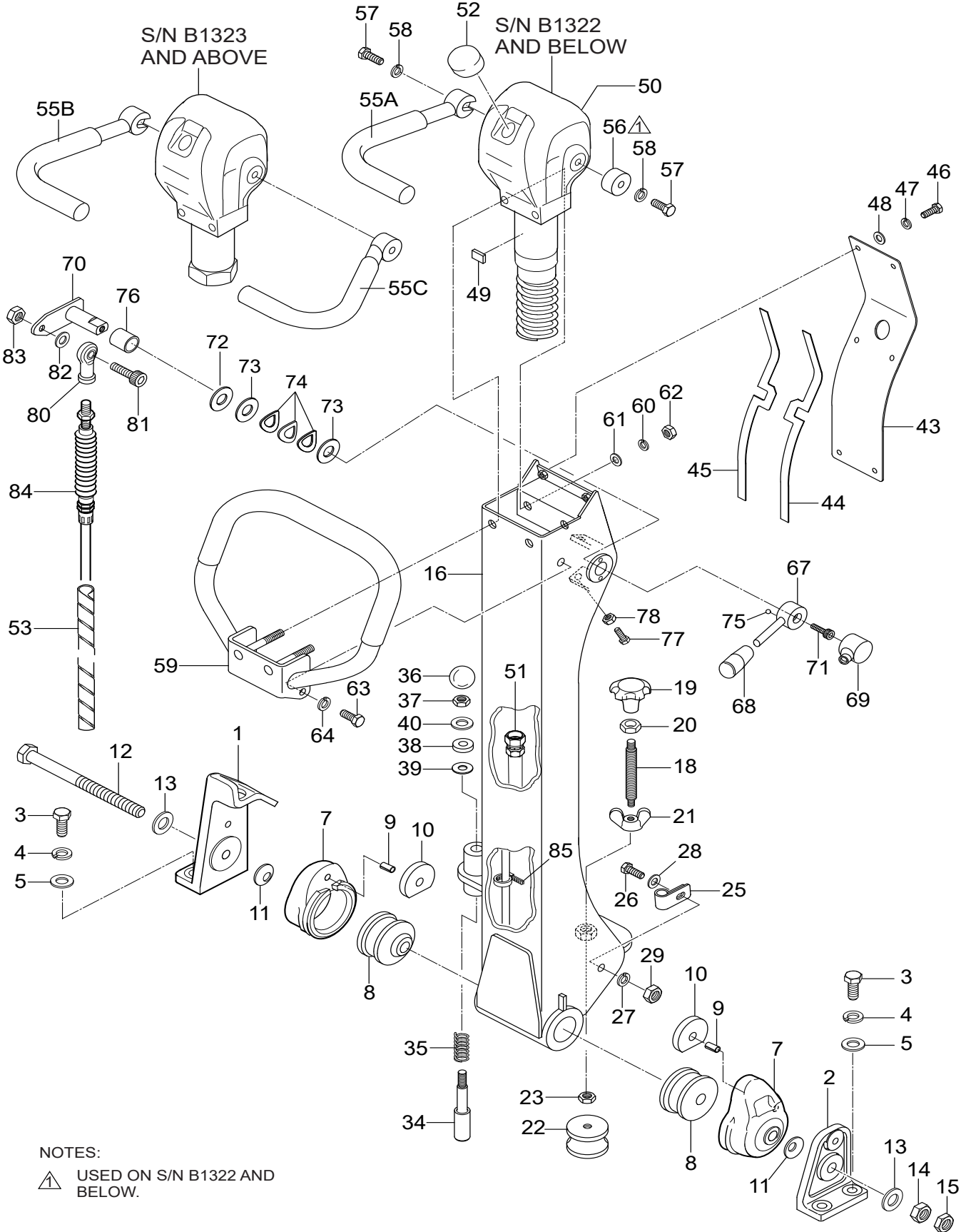

NOTES:
 ▲ USED ON S/N B1322 AND BELOW.

CONTROL ASSY.

<u>NO.</u>	<u>PART NO.</u>	<u>PART NAME</u>	<u>QTY.</u>	<u>REMARKS</u>
1	467351950	HANDLE BRACKET (R)	1	
2	467351960	HANDLE BRACKET (L)	1	
3	012212035	BOLT 12X35	4	REPLACES P/N 001221235
4	030212300	WASHER, LOCK M12	4	
5	031112230	WASHER, FLAT M12	4	
7	456336400	RUBBER COUPLING	2	
8	456449940	SHOCK ABSORBER	2	
9	025306016	SPRING PIN 6X16	2	REPLACES P/N 025406016
10	456449930	RUBBER PLATE	2	
11	032124400	CONICAL SPRING WASHER M24	2	
12	001221681	BOLT 16X250	1	
13	0401450160	WASHER, FLAT M16	2	REPLACES P/N 031116260
14	020316130	NUT M16	1	
15	020416100	NUT M16, H=10	1	
16	467121180	COLUMN, HANDLE BAR	1	
18	455434950	SPINDLE	1	
19	455010030	KNOB	1	
20	020412070	NUT M12, H=7	1	
21	022411635	WING NUT M16	1	
22	939010060	SHOCK ABSORBER 60	1	
23	020310080	NUT M10, H=6	1	REPLACES P/N 020410060
25	959408930	CLIP 15 (M6)	1	
26	011206020	BOLT 6X20	1	REPLACES P/N 001220620
27	030206150	WASHER, LOCK M6	1	
28	952404470	WASHER, FLAT M6	1	REPLACES P/N 031106100
29	020106050	NUT M6	1	REPLACES P/N 020306050
34	501402870	HANDLE STOPPER	1	
35	501402880	SPRING HANDLE	1	
36	959403460	BALL GRIP 32D-M10	1	
37	020310080	NUT M10.....	1	REPLACES P/N 020410060
38	456449980	RUBBER PACKING	1	
39	953405260	PACKING 1/4 (CU)	1	
40	031110160	WASHER, FLAT M10	1	
43	467351980	HANDLE COVER, DSY	1	
44	467467340	PACKING (L), HANDLE	1	
45	467467350	PACKING (R), HANDLE	1	
46	0105050616	BOLT 6X15	6	REPLACES P/N 001220615
47	030206150	WASHER, LOCK M6	6	
48	952404470	WASHER, FLAT M6	6	REPLACES P/N 031106100
49	464457930	RUBBER PIECE (T2)	1	
50	468219160	HYDRAULIC PUMP	1	

CONTROL ASSY. (CONT'D.)

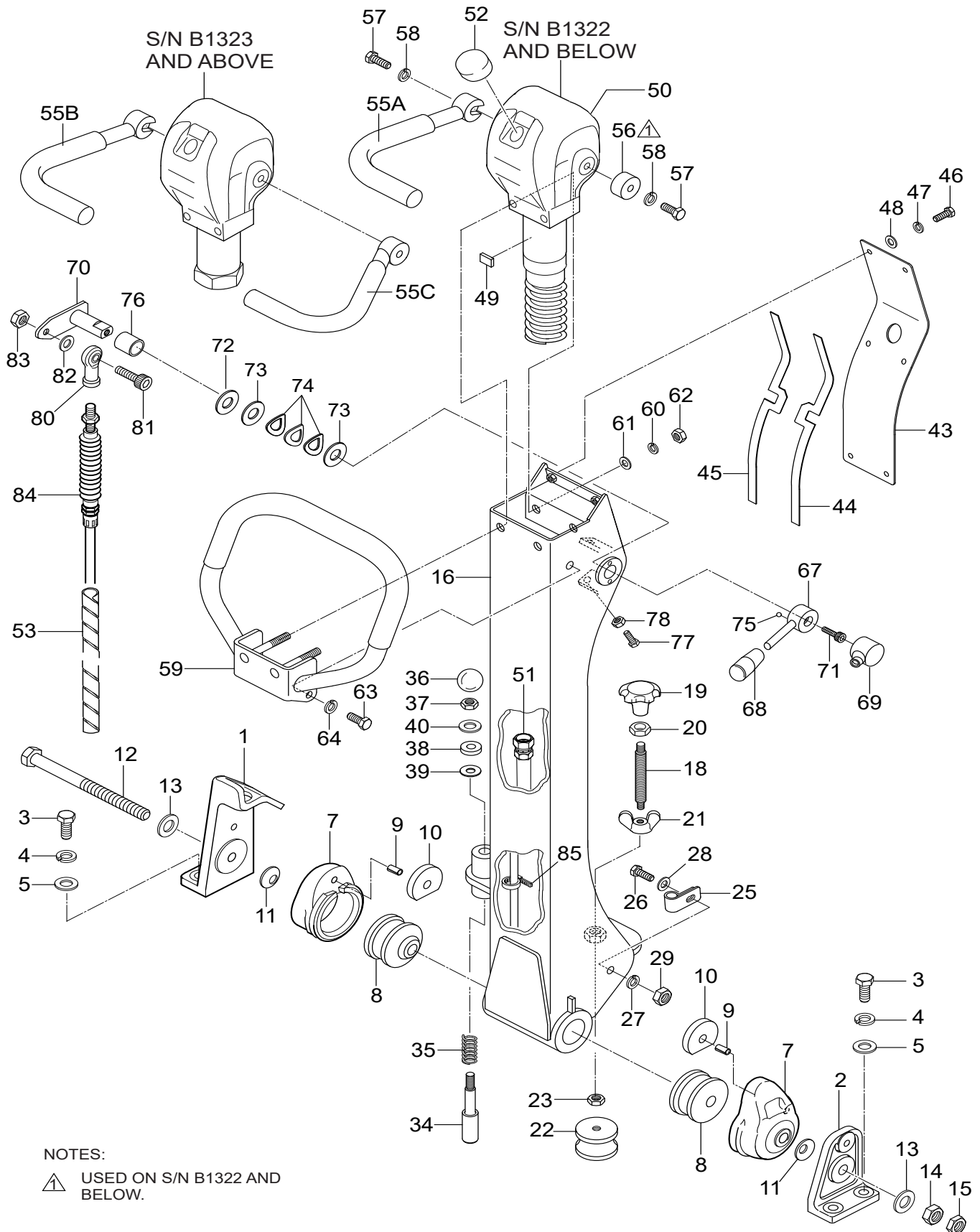

CONTROL ASSY. (CONT'D.)

<u>NO.</u>	<u>PART NO.</u>	<u>PART NAME</u>	<u>QTY.</u>	<u>REMARKS</u>
51	954003110	OIL HOSE	1	
52	458451630	BREATHER CAP	1	
53	959021813	SPIRAL TUBE	1	
55A	464216630	TRAVEL LEVER, RIGHT	1.....	S/N B1322 AND BELOW
55B	464216820	TRAVEL LEVER, RIGHT	1.....	S/N B1323 AND ABOVE
55C	464216830	TRAVEL LEVER, LEFT.....	1.....	S/N B1323 AND ABOVE
56	464457400	HANDLE BOSS	1.....	S/N B1322 AND BELOW
57	012010030	BOLT 10X30	2.....	REPLACES P/N 001221030
58	030210250	WASHER, LOCK M10	2	
59	467218900	HANDLE W/RUBBER GRIP	1	
60	030210250	WASHER, LOCK M10	2	
61	031110160	WASHER, FLAT M10	2	
62	020310080	NUT M10	2	
63	0105091025	BOLT 10X25	2.....	REPLACES P/N 001221025
64	030210250	WASHER, LOCK M10	2	
67	467467380	THROTTLE LEVER	1	
68	959403840	BAR GRIP, I.D. 12MM	1	
69	464457420	COVER, THROTTLE LEVER	1	
70	464457350	ARM, THROTTLE	1	
71	014208020	SOCKET HEAD BOLT 8X20	1.....	REPLACES P/N 001520820
72	0401450160	WASHER, FLAT M16.....	1.....	REPLACES P/N 031116260
73	458450660	WASHER 16.4-35-0.6	2	
74	033910080	CONICAL WASHER, LOCK 16.3X31.5X1.2	3	
75	464457440	STEEL BALL	1	
76	464010010	DRY BUSHING	1	
77	011606025	BOLT 6X25	2.....	REPLACES P/N 001220625
78	020106050	NUT M6.....	2.....	REPLACES P/N 020306050
80	464010020	ROD END M5	1	
81	001520520	SOCKET HEAD BOLT 5X20	1	
82	58151	WASHER, FLAT M5.....	1.....	REPLACES P/N 031105080
83	020305040	NUT M5	1	
84	956100070	THROTTLE WIRE	1	
85	454010020	CLAMP	1	

HYDRAULIC HAND PUMP ASSY.

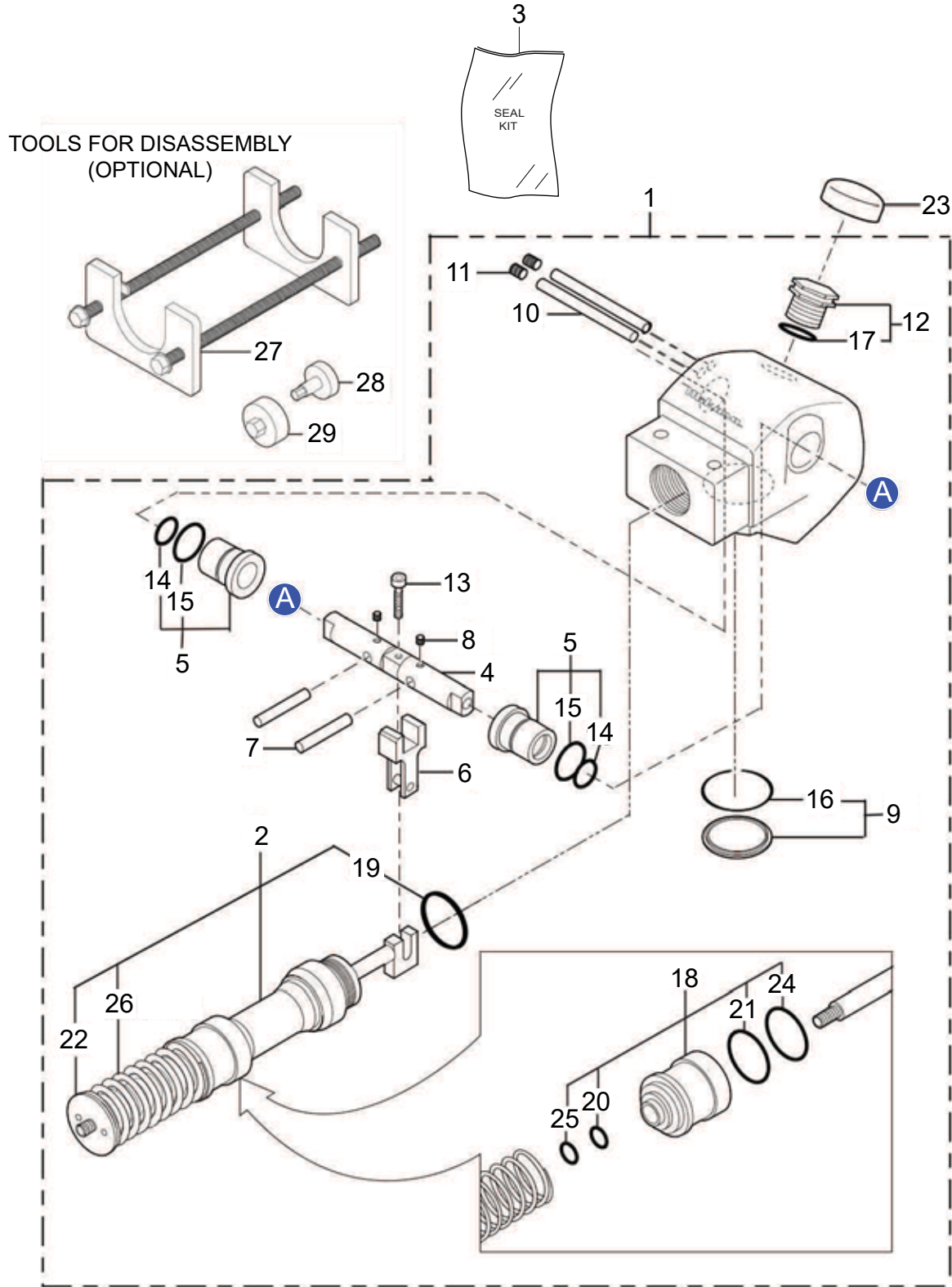

HYDRAULIC HAND PUMP ASSY.

<u>NO.</u>	<u>PART NO.</u>	<u>PART NAME</u>	<u>QTY.</u>	<u>REMARKS</u>
1	468219160	HAND PUMP	1.....	INCLUDES ITEMS W/#
2#	468910020	ACCUMULATOR.....	1.....	INCLUDES ITEMS W/\$ NOT SOLD SEPARATELY
3	464910080	SEAL KIT	1.....	INCLUDES ITEMS W/%
4#	464010040	CONTROL SHAFT	1	
5#	467010020	BUSH.....	2.....	INCLUDES ITEMS W/@
6#	464010060	CAM	1	
7#	464010070	STOPPER	2	
8#	099205005	SCREW, SOCKET HEAD	2	
9#	464010080	PLUG	1.....	INCLUDES ITEMS W/*
10#	464010090	PIN, STOPPER	2	
11#	464010100	PLUG	2	
12#	458010080	BREATHER.....	1.....	INCLUDES ITEMS W/^
13#	001520620	BOLT, SOCKET HEAD.....	1.....	REPLACES P/N 001520620
14@%#	050200200	O-RING, P-20	2	
15@%#	050210220	O-RING, P-22	2.....	REPLACES P/N 050200220
16*%#	050300380	O-RING, S-38	1	
17^%#	050200180	O-RING, P-18	1	
18\$#	464010111	CASE, ACCUMULATOR	1.....	INCLUDES ITEMS W/&
19\$%#	050300400	O-RING, S-40	1	
20\$&%#	050200150	O-RING, P-15	1	
21\$&%#	050100400	O-RING, G-40	1	
22\$#	468010010	PLUG, SPRING	1	
23#	458451630	CAP, BREATHER	1	
24\$&%#	069904010	SEAL, SER-40	1	
25\$&%#	069901010	SEAL, SER-15	1	
26\$#	468910030	SPRING, ACCUMULATOR	1	
27	984010060	SPRING COMPRESSION, TOOL	1	
28	984010040	TOOL A, DISASSEMBLING	1	
29	984010050	TOOL B, DISASSEMBLING	1	

HONDA GX390UT2SMXC/SCM ENG. — CYLINDER HEAD ASSY.

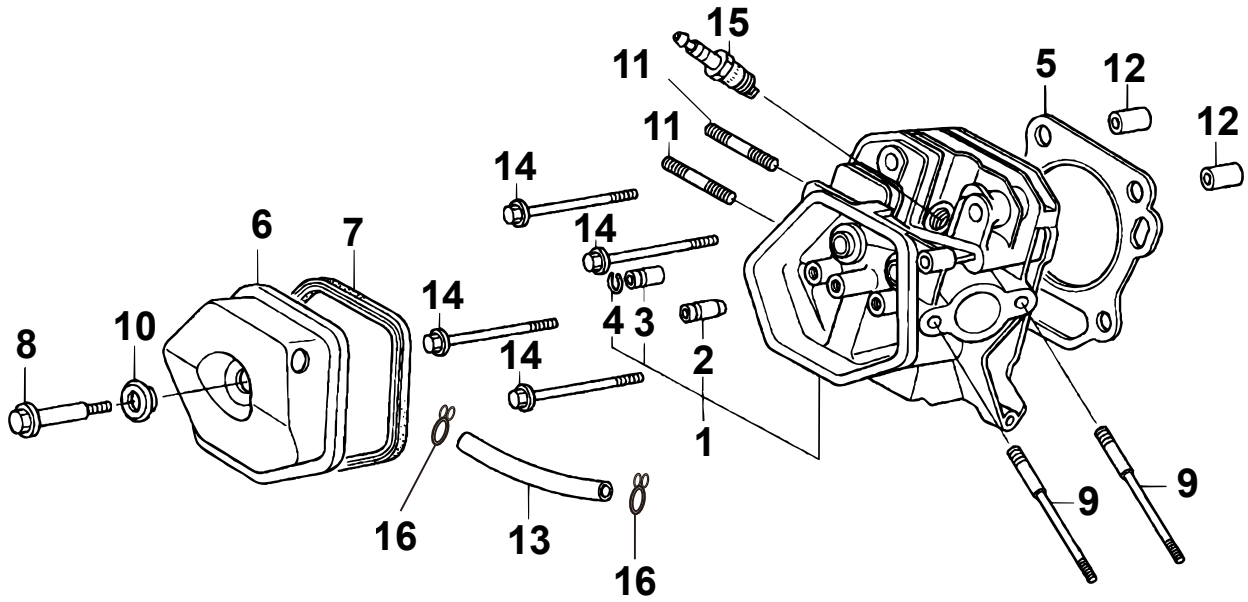

HONDA GX390UT2SMXC/SCM ENG. — CYLINDER HEAD ASSY.

<u>NO.</u>	<u>PART NO.</u>	<u>PART NAME</u>	<u>QTY.</u>	<u>REMARKS</u>
1	12210Z5T416	HEAD COMP., CYLINDER	1.....	INCLUDES ITEMS W/#
2#	12204ZE2306	GUIDE, IN. VALVE (OVERSIZE)	1	
3#	12205ZE2305	GUIDE, EX. VALVE (OVERSIZE)	1	
4#	12216ZE2300	CLIP, VALVE GUIDE	1	
5	12251Z5T003	GASKET, CYLINDER HEAD	1	
6	12310ZE3791	COVER COMP., HEAD	1	
7	12391ZE2020	PACKING, HEAD COVER	1	
8	90014Z5T000	BOLT, HEAD COVER	1	
9	90042ZE8000	BOLT, STUD 8X31.5	2	
10	90441ZE2010	WASHER COMP., HEAD COVER	1	
11	92900080320E	BOLT, STUD 8X32	2	
12	9430112200	PIN, DOWEL 12X20	2	
13	12315ZE3840	TUBE, BREATHER	1	
14	957011008000	BOLT, FLANGE 10X80	4	
15	0650140480	SPARK PLUG	1	
16	17316611000	CLIP, BREATHER TUBE	2	

HONDA GX390UT2SMXC/SCM ENG. — CYLINDER BARREL ASSY.

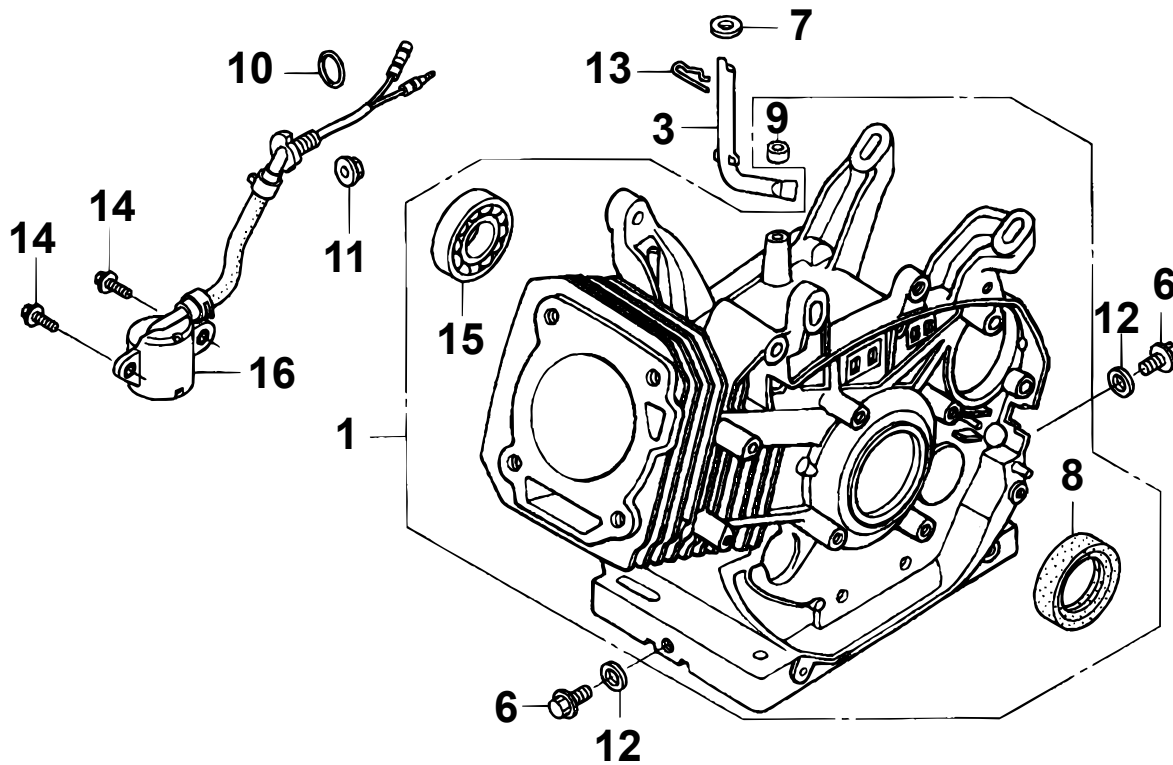

HONDA GX390UT2SMXC/SCM ENG. — CYLINDER BARREL ASSY.

<u>NO.</u>	<u>PART NO.</u>	<u>PART NAME</u>	<u>QTY.</u>	<u>REMARKS</u>
1	12000Z5T407	BARREL ASSY., CYLINDER/ALERT	1.....	INCLUDES ITEMS W/\$
3	16541ZE3010	SHAFT, GOVERNOR ARM	1	
6	90131896650	BOLT, DRAIN PLUG	2	
7	90446KE1000	WASHER 8.2X17X0.8	1	
8\$	91201Z1C003	OIL SEAL	1	
9\$	91201ZE9003	OIL SEAL	1.....	REPLACES P/N 91203952771
10	91353671003	O-RING 14MM	1.....	REPLACES P/N 91353671004
11	9405010000	FLANGE NUT M10	1	
12	9410912000	WASHER, DRAIN PLUG M12	2	
13	9425110000	PIN LOCK 10MM	1	
14	957010601200	FLANGE BOLT 6X12	2	
15\$	961006202000	BEARING, RADIAL BALL 6202	1	
16	35480ZF6003	SWITCH ASSY., OIL LEVEL	1	

HONDA GX390UT2SMXC/SCM ENG. — CRANKCASE COVER ASSY.

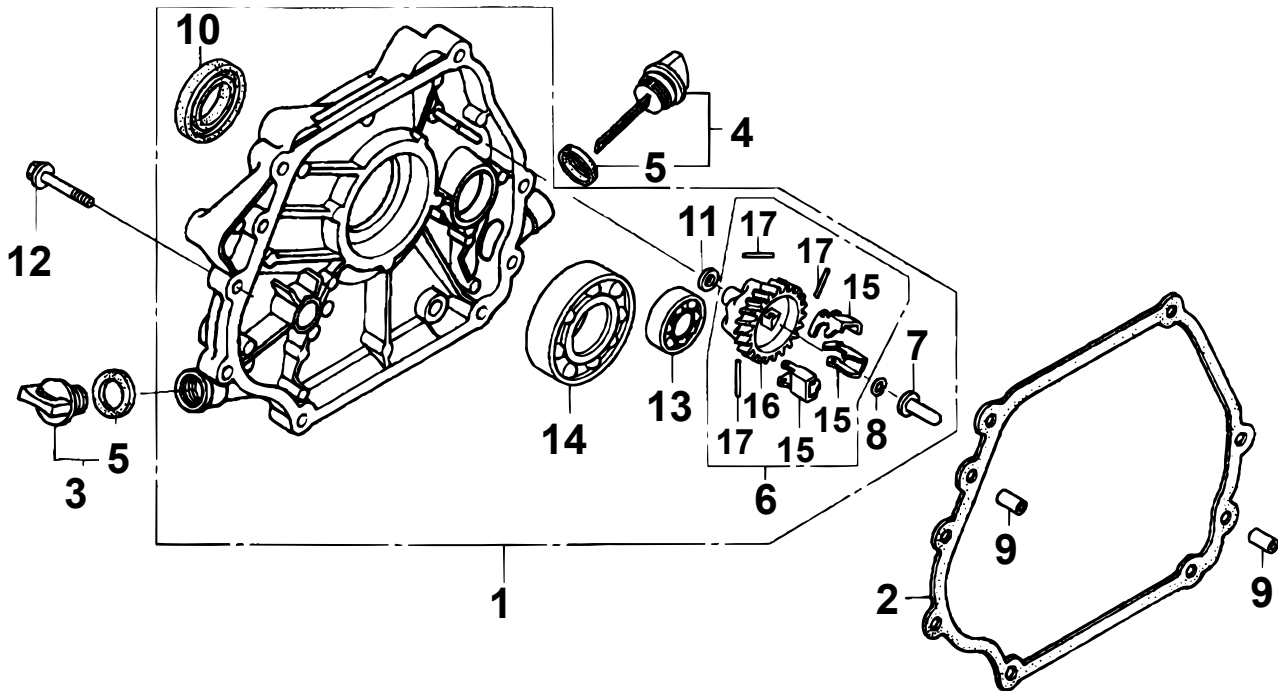

HONDA GX390UT2SMXC/SCM ENG. — CRANKCASE COVER ASSY.

<u>NO.</u>	<u>PART NO.</u>	<u>PART NAME</u>	<u>QTY.</u>	<u>REMARKS</u>
1	11300Z8W800	COVER ASSY., CRANKCASE/S-TYPE.....	1.....	INCLUDES ITEMS W/@
2	11381Z5T000	PACKING, CRANKCASE COVER	1	
3	15600Z0T820	CAP ASSY., OIL FILLER	1.....	INCLUDES ITEM W/\$
4	15600Z1C000	CAP ASSY., OIL FILLER	1.....	INCLUDES ITEM W/%
5\$%	15625Z0T800	PACKING, OIL FILLER CAP	2	
6@	16510ZE3000	GOVERNOR ASSY.....	1.....	INCLUDES ITEMS W/#
7@	16531Z0A000	SLIDER, GOVERNOR	1	
8@	90602ZE1000	CLIP, GOVERNOR HOLDER	1	
9	90701HC4000	PIN, DOWEL	2	
10@	91201Z1C003	OIL SEAL	1	
11@	58176	WASHER, FLAT 6MM.....	1.....	REPLACES P/N 9410106800
12	957010804000	BOLT, FLANGE 8X40	7	
13@	961006202000	BEARING, RADIAL BALL 6202	1	
14@	961006207000	BEARING, RADIAL BALL 6207	1	
15@#	16511ZE8000	WEIGHT, GOVERNOR	3	
16@#	16512ZE3000	HOLDER, GOVERNOR WEIGHT	1	
17@#	16513ZE2000	PIN, GOVERNOR WEIGHT	3	

HONDA GX390UT2SMXC/SCM ENG. — CRANKSHAFT ASSY.

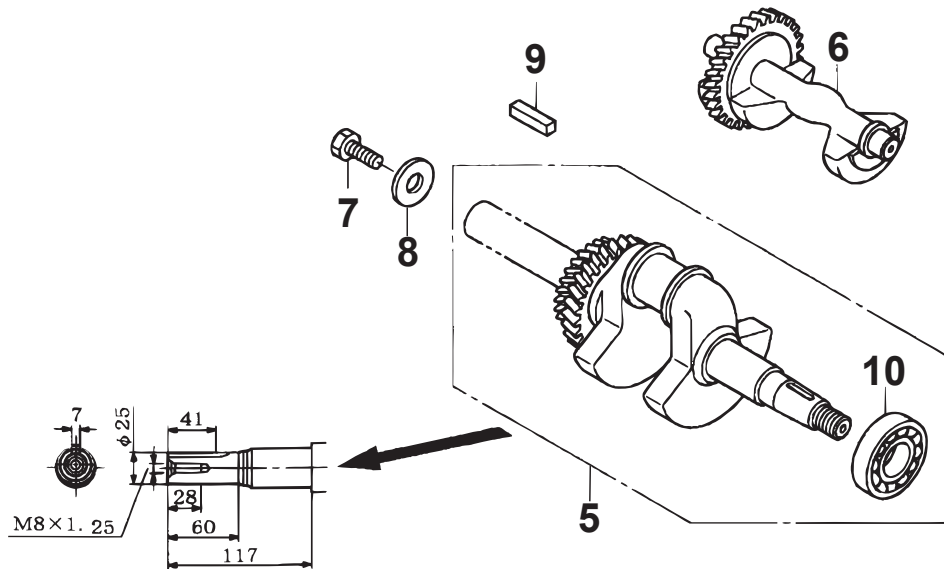

HONDA GX390UT2SMXC/SCM ENG. — CRANKSHAFT ASSY.

NO.	PART NO.	PART NAME	QTY.	REMARKS
5	13310ZF6W72	CRANKSHAFT.....	1.....	INCLUDES ITEM W/#
6	13351Z1C900	WEIGHT, BALANCER	1	
7◆	92101080250A	BOLT 8X25	1	
8◆	90534706010	WASHER, LOCK 8MM	1	
9	90741889810	KEY 7X7X33.....	1.....	REPLACES P/N 90741805000
10#	91001ZF6013	BEARING, RADIAL BALL 6207SH	1	

NOTICE

- ◆ GX390UT2SMXC
- ◇ GX390UT2SCM

HONDA GX390UT2SMXC/SCM ENG. — PISTON ASSY.

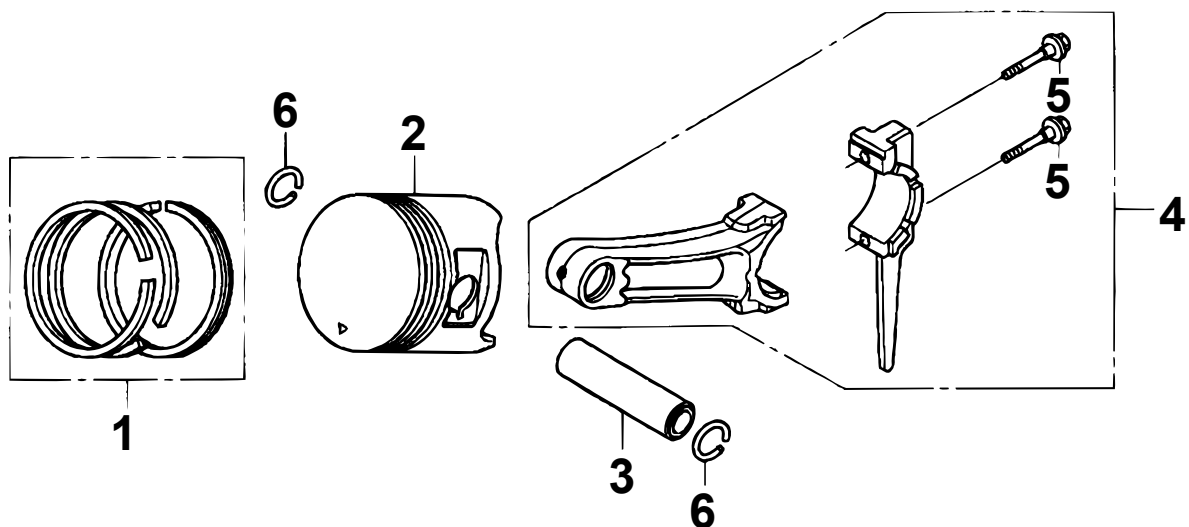

HONDA GX390UT2SMXC/SCM ENG. — PISTON ASSY.

NO.	PART NO.	PART NAME	QTY.	REMARKS
1	13010Z5R004	RING SET, PISTON (STD)	1	
1	13011Z5R004	RING SET, PISTON (0.25)	1	
1	13012Z5R004	RING SET, PISTON (0.50)	1	
1	13013Z5R004	RING SET, PISTON (0.75)	1	
2	13101Z1C900	PISTON (STD)	1	
2	13102Z5T800	PISTON (0.25)	1	
2	13103Z5T800	PISTON (0.50)	1	
2	13104Z5T800	PISTON (0.75)	1	
3	13111Z5T000	PIN, PISTON	1	
4	13200Z1C900	ROD ASSY., CONNECTING /STD.....	1	INCLUDES W/%
4◆	13200Z1C305	ROD ASSY., CONNECTING 0.25UN.....	1	INCLUDES W/\$
5%\$	90001ZE8000	BOLT, CONNECTING ROD	2	
6	90601ZE3000	CLIP, PISTON PIN 20MM	2	

NOTICE

◆ GX390UT2SMXC

◇ GX390UT2SCM

HONDA GX390UT2SMXC/SCM ENG. — CAMSHAFT ASSY.

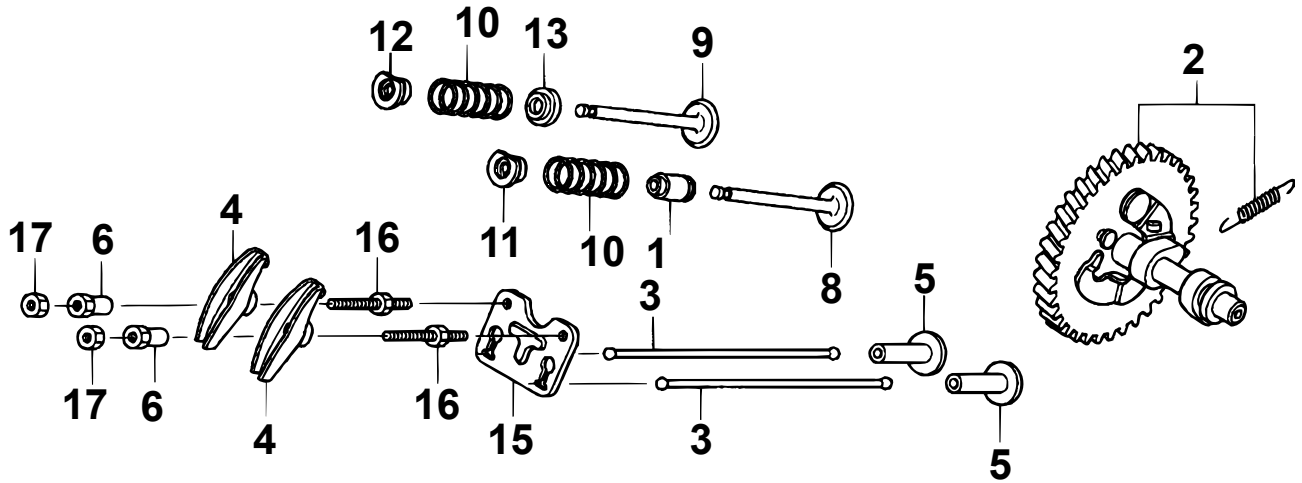

HONDA GX390UT2SMXC/SCM ENG. — CAMSHAFT ASSY.

<u>NO.</u>	<u>PART NO.</u>	<u>PART NAME</u>	<u>QTY.</u>	<u>REMARKS</u>
1	12209ZE8003	SEAL, VALVE STEM	1	
2	14100Z5T910	CAMSHAFT ASSY.	1	
3	14410Z1C000	ROD, PUSH	2	
4	14431ZE2010	ARM, VALVE ROCKER	2	
5	14441ZE2000	LIFTER, VALVE	2	
6◆	14451ZE1013	PIVOT, ROCKER ARM	2	
6◇	14451Z4M000	PIVOT, ROCKER ARM	2	
8	14711Z5T900	VALVE, IN.	1	
9	14721Z5T900	VALVE, EX.	1	
10	14751Z1C000	SPRING, VALVE	2	
11	14771Z8S000	RETAINER, VALVE SPRING	1	
12	14771Z8S000	RETAINER, VALVE SPRING	1	
13	14775ZE2010	SEAT, VALVE SPRING	1	
15	14791Z1D000	PLATE, PUSH ROD GUIDE	1	
16	90012ZE0010	BOLT, PIVOT, 8MM	2	
17	90206ZE1000	NUT, PIVOT ADJUSTING	2	

NOTICE

◆ GX390UT2SMXC

◇ GX390UT2SCM

HONDA GX390UT2SMXC/SCM ENG. — RECOIL STARTER ASSY.

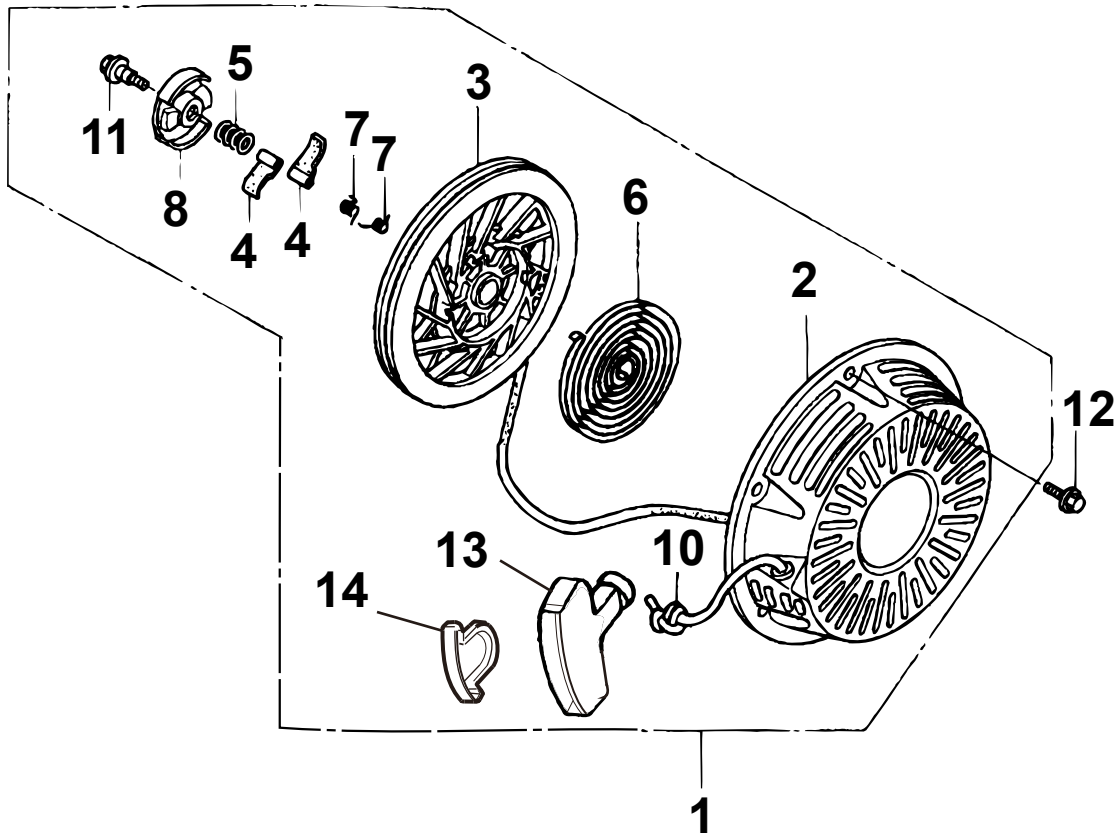

HONDA GX390UT2SMXC/SCM ENG. — RECOIL STARTER ASSY.

NO.	PART NO.	PART NAME	QTY.	REMARKS
1◆	28400ZE3W01ZB	STARTER ASSY.....	1.....	REPLACES P/N28400ZE3W02ZB INCLUDES ITEMS W/#
1◇	28400Z5T305ZB	STARTER ASSY.....	1.....	INCLUDES ITEMS W/%
2#%	28410ZE3W01ZB	CASE COMPLETE, RECOIL STARTER	1	
3#%	28421ZE3W01	PULLEY, RECOIL STARTER	1	
4#%	28422ZE2W01	RATCHET, STARTER	2	
5#%	28441ZE2W01	SPRING FRICTION	1	
6#%	28442ZE2W01	SPRING, STARTER RETURN	1	
7#%	28443ZE2W01	SPRING, RATCHET	2	
8#%	28444ZE2W01	RETAINER, SPRING	1	
10#%	28462ZE3W01	ROPE, RECOIL STARTER	1.....	REPLACES P/N 28462ZE3W01
11#%	90004ZE2W01	SCREW, CENTER	1	
12	957010601000	FLANGE BOLT 6X10	3	
13#%	28461Z5T305	GRIP, STARTER	1	
14#%	28463Z5T013	GRIP, REINFORCEMENT	1	

NOTICE

◆ GX390UT2SMXC

◇ GX390UT2SCM

HONDA GX390UT2SMXC/SCM ENG. — FAN COVER ASSY.

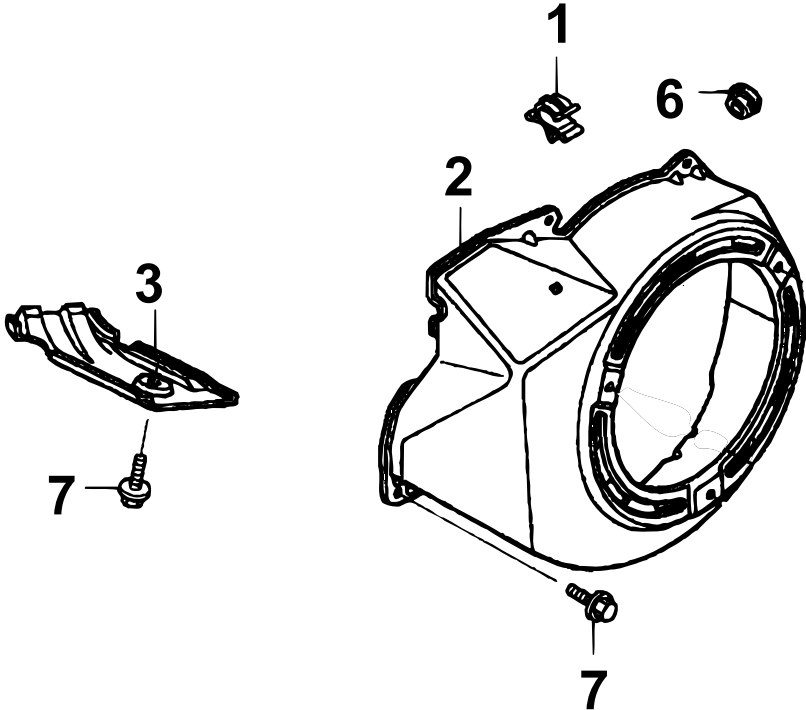

HONDA GX390UT2SMXC/SCM ENG. — FAN COVER ASSY.

<u>NO.</u>	<u>PART NO.</u>	<u>PART NAME</u>	<u>QTY.</u>	<u>REMARKS</u>
1	16731ZE2003	CLIP, TUBE	1	
2	19610Z5T000ZB	COVER COMPLETE, FAN/BLACK	1	
3	19631Z5T000	SHROUD	1	
6	81329567020	GROMMET, DRAIN HOLE	1	
7	90013883000	FLANGE BOLT 6X12	6	

HONDA GX390UT2SMXC/SCM ENG. — CARBURETOR ASSY.

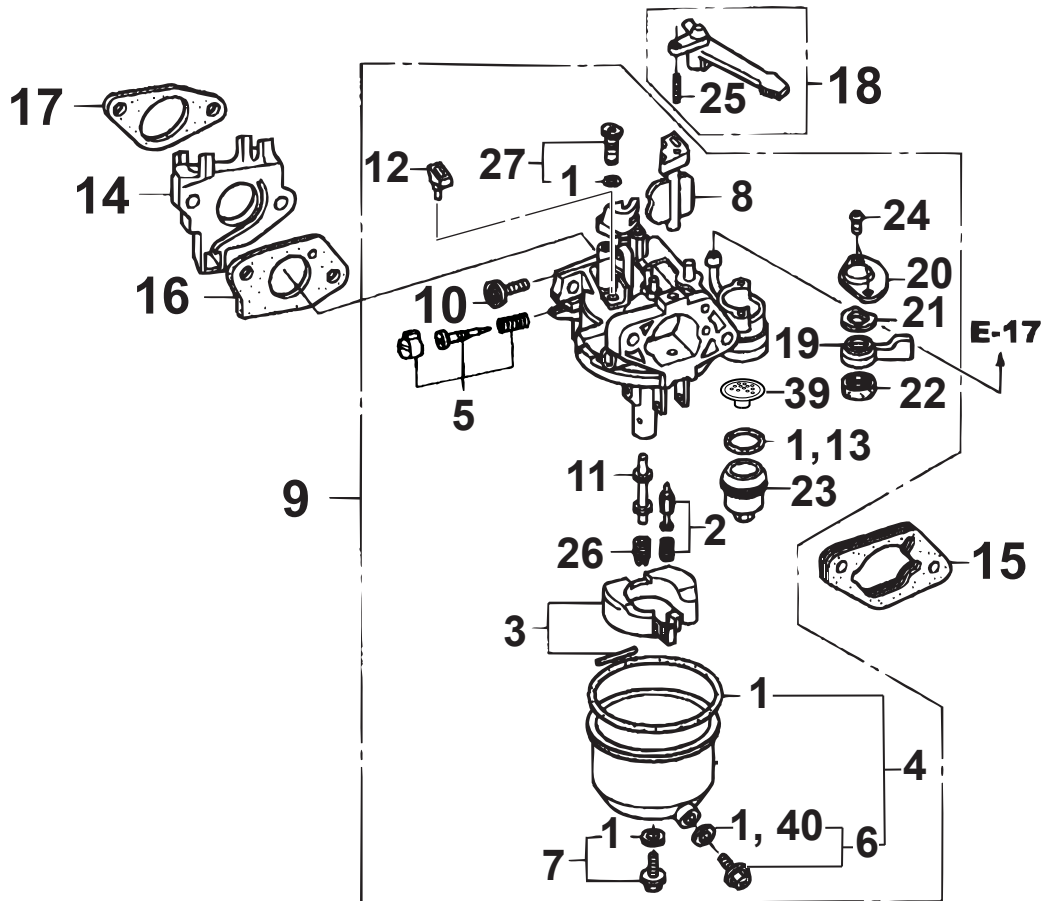

NOTICE

Gasket set, item 1 included with items 4, 7, 13, 27 and 40.

HONDA GX390UT2SMXC/SCM ENG. — CARBURETOR ASSY.

NO.	PART NO.	PART NAME	QTY.	REMARKS
1#	16010ZE2812	GASKET SET	1	
2#%	16011ZA0931	VALVE SET, FLOAT	1	
3#%	16013Z1C003	FLOAT SET	1	
4#%	16015Z5T901	CHAMBER SET, FLOAT	1	INCLUDES ITEM W/
5#%	16016ZH7W01	SCREW SET PILOT	1	
6#%	16024Z5T901	SCREW SET, DRAIN	1	
7#%	16028Z5T901	SCREW SET.....	1	INCLUDES ITEM W/
8#%	16044Z5T901	CHOKE SET	1	
9	16100Z5TP72	CARBURETOR ASSY., BE94F A (◆ ENGINE) ..	1	INCLUDES ITEMS W/#
9	16100-Z5T-781	CARBURETOR ASSY., BE94J A (◇ ENGINE) ...	1	INCLUDES ITEMS W/%
10#%	16124ZE0005	SCREW, THROTTLE STOP	1	
11#	16166Z5T931	NOZZLE MAIN	1	
11%	16166-Z5T-781	NOZZLE MAIN	1	
12#%	16172ZE3W10	COLLAR SET	1	
13#%	16955283000	PACKING, CUP.....	1	INCLUDES ITEM W/
14	16211Z5T000	INSULATOR, CARBURETOR	1	
15	16220ZA0702	SPACER COMP. CARBURETOR	1	
16	16221Z5T000	PACKING, CARBURETOR	1	
17	16212Z5T000	PACKING, INSULATOR	1	
18	16610ZE1000	CHOKE LEVER COMP.	1	INCLUDES ITEM W/\$
19#%	16953ZE1812	LEVER, COCK	1	
20#%	16954ZE1812	PLATE, LEVER SETTING	1	
21#%	16956ZE1811	SPRING, COCK LEVER	1	
22#%	16957ZE1812	PACKING, FUEL COCK	1	
23#%	16967ZE0811	CUP, FUEL STRAINER	1	
24#%	93500030060H	SCREW 3X6	3	
25\$	9430520122	SPRING PIN 2X12	1	
26#	99101ZH81080	JET, MAIN #92	1	
26%	99101-ZH81180	JET, MAIN #118	1	
27#%	99204ZA00450	PILOT JET SET #45	1	INCLUDES ITEM W/
39#%	16959Z5T901	FILTER, CUP	1	
40◇%	16141Z0S003	WASHER, FLAT	1	INCLUDES ITEM W/

NOTICE

◆ GX390UT2SMXC

◇ GX390UT2SCM

HONDA GX390UT2SMXC ENG. — AIR CLEANER ASSY.

<u>NO.</u>	<u>PART NO.</u>	<u>PART NAME</u>	<u>QTY.</u>	<u>REMARKS</u>
1	16271ZE2010	PACKING, ELBOW	1	
2	17210ZE3505	ELEMENT, AIR CLEANER	1.....	INCLUDES ITEMS W/#
3#	17218ZE3505	FILTER, OUTER	1	
4\$	17219HA2405	PACKING, AIR CLEANER COVER.....	1.....	REPLACES P/N 17219ZE3840
5	17230ZE3841	COVER COMP., AIR CLEANER	1	
6#	17232891000	GROMMET, AIR CLEANER	1	
7\$	17238ZE2310	COLLAR, AIR CLEANER	2	
8\$	17239ZE3840	COLLAR B, AIR CLEANER	1	
9	17410ZE3841	ELBOW COMP., AIR CLEANER.....	1.....	INCLUDES ITEMS W/\$
10	17470ZE3842	CASE COMP., PRE-AIR CLEANER	1	
11	17475ZE3841	CAP, PRE-AIR CLEANER	1	
12	17476ZE3841	GUIDE, PRE-AIR CLEANER	1	
13	90009Z1C000	BOLT, WASHER 6X22	1	
14	90142MB0000	SCREW, PAN 5X16.5	5	
15	90325044000	NUT, TOOL BOX SETTING	2	
16	9405006000	FLANGE NUT 6MM	2	

HONDA GX390UT2SCM ENG. — AIR CLEANER ASSY. (CYCLONE)

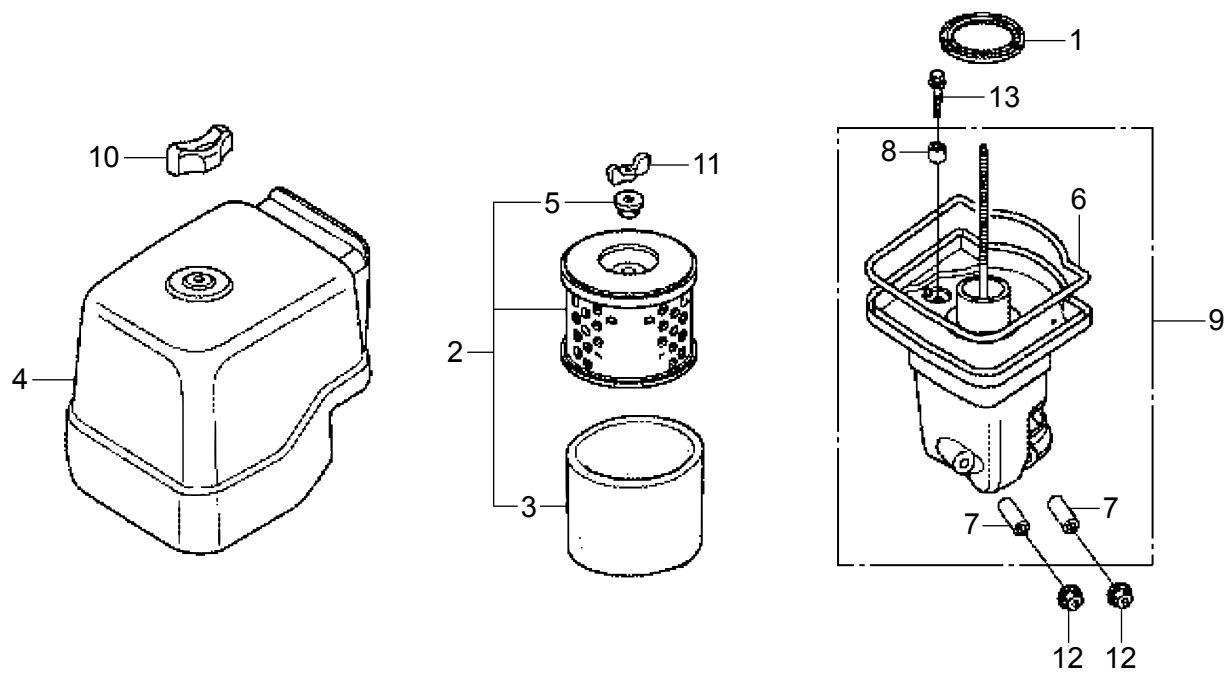

HONDA GX390UT2SCM ENG. — AIR CLEANER ASSY. (CYCLONE)

<u>NO.</u>	<u>PART NO.</u>	<u>PART NAME</u>	<u>QTY.</u>	<u>REMARKS</u>
1	17417Z5T000	PACKING, ELBOW	1	
2	17210Z1C781	ELEMENT, AIR CLEANER	1.....	INCLUDES ITEMS W/#
3#	17218Z1C780	FILTER, OUTER	1	
4	17230Z1C780	COVER ASSY., AIR CLEANER	1	
5#	17232891000	GROMMET, AIR CLEANER	1	
6%	17233Z1C780	SEAL, AIR CLEANER COVER	1	
7%	17238ZE2310	COLLAR, AIR CLEANER	2	
8%	17239ZE3840	COLLAR B, AIR CLEANER	1	
9	17410Z1C780	ELBOW COMPLETE, AIR CLEANER	1.....	INCLUDES ITEMS W/%
10	90300Z4M800	NUT, AIR CLEANER	1	
11	90325044000	NUT, TOOL BOX SETTING	1	
12	9405006000	FLANGE NUT 6MM	2	
13	90009Z1C000	FLANGE BOLT 6X22	1	

HONDA GX390UT2SMXC/SCM ENG. — MUFFLER ASSY.

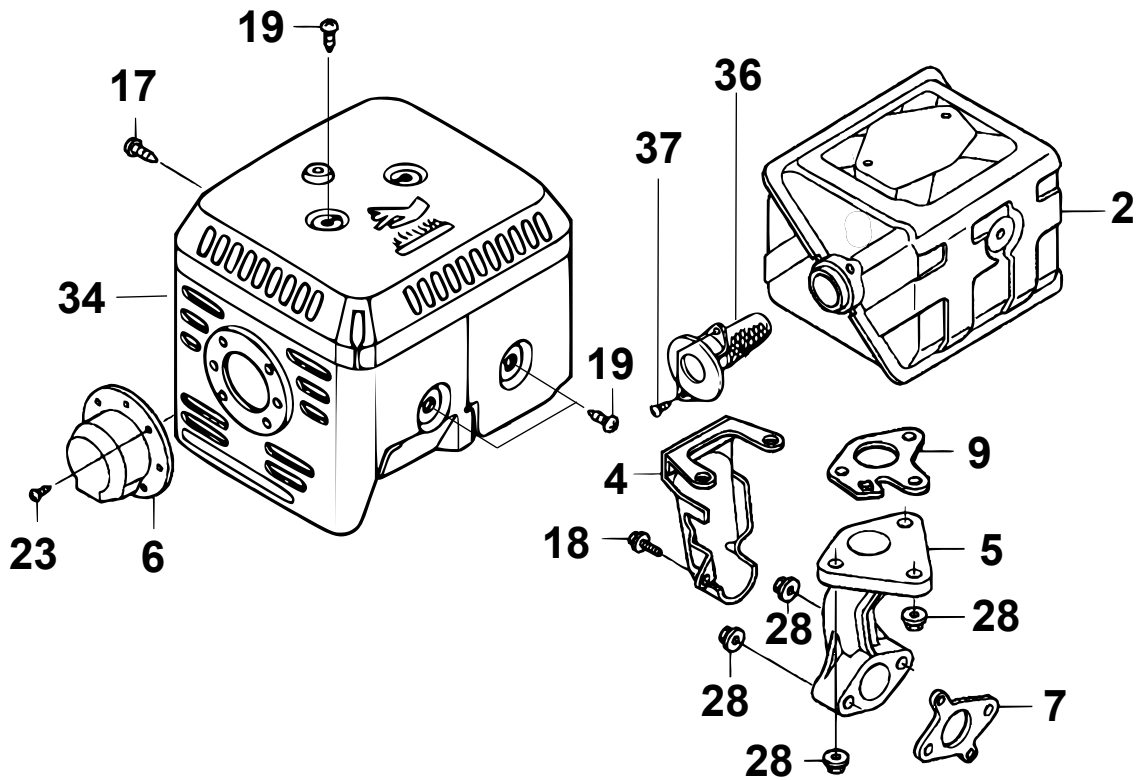

HONDA GX390UT2SMXC/SCM ENG. — MUFFLER ASSY.

<u>NO.</u>	<u>PART NO.</u>	<u>PART NAME</u>	<u>QTY.</u>	<u>REMARKS</u>
2	18310Z5T010	MUFFLER COMP.	1	
4	18323Z5TW41	PROTECTOR, EXHAUST PIPE	1	
5	18331Z5T000	PIPE, EXHAUST	1	
6	18331ZE3811	CAP, MUFFLER	1	
7	18333Z1C901	GASKET EX. PIPE	1	
9◆	18381ZE2W10	GASKET, MUFFLER (ARRESTER)	1	
9◇	18381Z8S801	GASKET, MUFFLER (ARRESTER)	1	
17	90006ZE2000	TAPPING SCREW 6X10	1	
18	90013883000	FLANGE BOLT 6X12	1	
19◆	90050ZE1000	TAPPING SCREW 5X8	4	
23	90055ZE1000	TAPPING SCREW 4X6	3	
28	9405008000	FLANGE NUT M8	5	
34	18320Z5T000	PROTECTOR COMP., MUFFLER	1	
36	18350Z5T800	ARRESTER COMP., SPARK	1	
37	90050ZE1000	TAPPING SCREW 5X8	5	

NOTICE

◆ GX390UT2SMXC

◇ GX390UT2SCM

HONDA GX390UT2SMXC/SCM ENG. — FUEL TANK ASSY.

<u>NO.</u>	<u>PART NO.</u>	<u>PART NAME</u>	<u>QTY.</u>	<u>REMARKS</u>
1	16854ZH8000	RUBBER, SUPPORT (107MM)	1	
3	16955ZE1010	JOINT, FUEL TANK	1	
4	17510Z5T000ZA	TANK COMP., FUEL/BLACK	1	
12	91353671003	O-RING 14MM.....	1.....	REPLACES P/N 91353671004
14	91424Z5T003	TUBE, FUEL, 4.5X235	1	
15	9405008000	FLANGE NUT M8	2	
16	950024080008	CLAMP, TUBE (D8)	1	
17	957010802500	FLANGE BOLT 8X25	2	
18	17620Z4H900	FUEL TANK CAP COMP.	1.....	INCLUDES ITEM W/#
19#	17631Z0T801	PACKING, FUEL FILLER CAP	1	
22	17672Z4H000	FILTER, FUEL	1	

HONDA GX390UT2SMXC/SCM ENG. — FLYWHEEL ASSY.

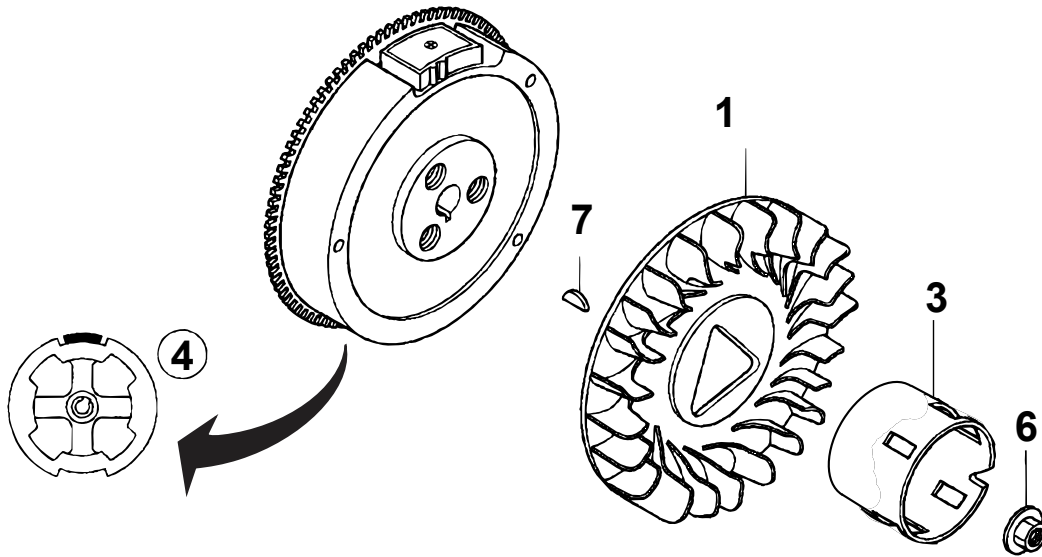

HONDA GX390UT2SMXC/SCM ENG. — FLYWHEEL ASSY.

<u>NO.</u>	<u>PART NO.</u>	<u>PART NAME</u>	<u>QTY.</u>	<u>REMARKS</u>
1	19511ZE3000	FAN, COOLING	1	
3	28451ZE3W01	PULLEY, STARTER	1	
4	31110Z5T000	FLYWHEEL COMP.	1	
6	90201ZE3V00	NUT, SPECIAL 16MM	1	
7	90741ZE2000	KEY SPECIAL WOODRUFF 25X18	1	

HONDA GX390UT2SMXC/SCM ENG. — IGNITION COIL ASSY.

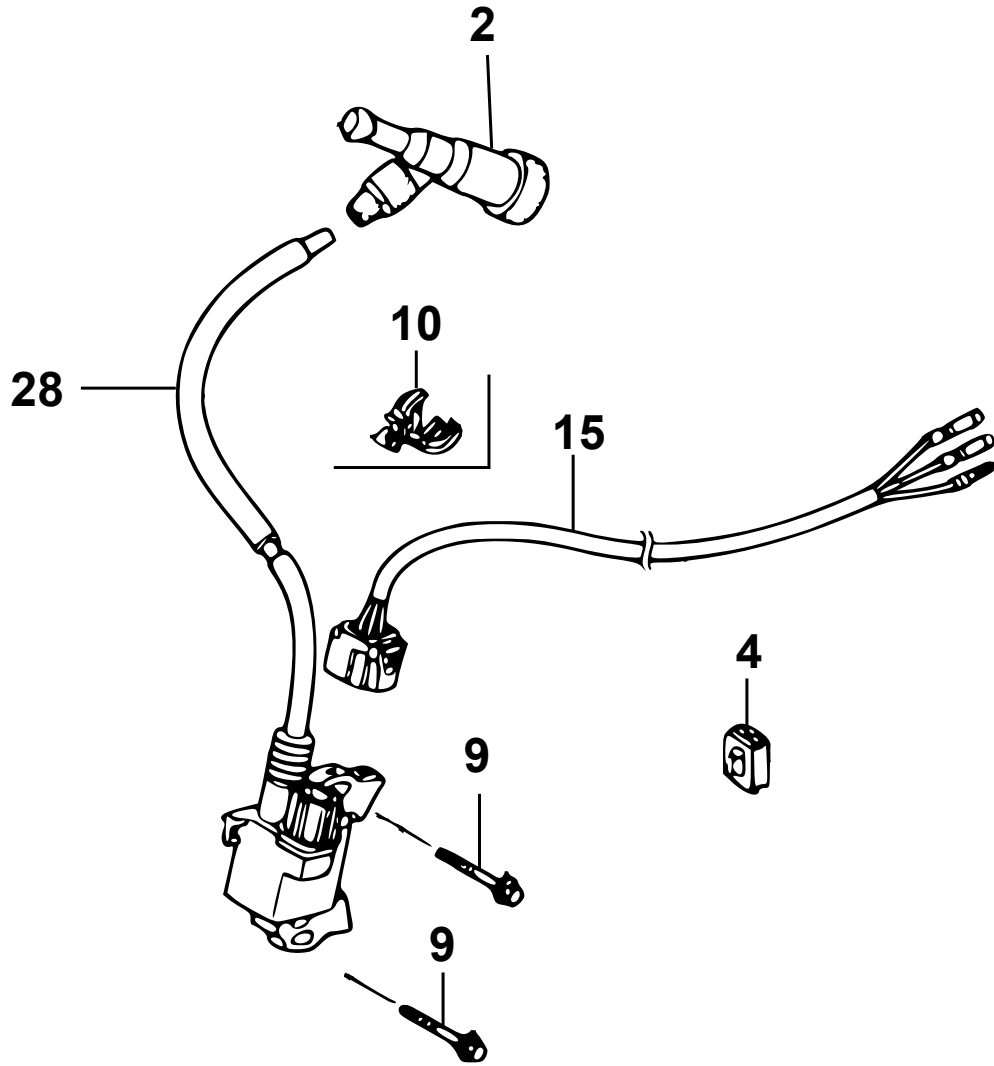

HONDA GX390UT2SMXC/SCM ENG. — IGNITION COIL ASSY.

<u>NO.</u>	<u>PART NO.</u>	<u>PART NAME</u>	<u>QTY.</u>	<u>REMARKS</u>
2◆	30700Z1C811	CAP ASSY., NOISE SUPPRESOR	1	
2◇	30700Z1C813	CAP ASSY., NOISE SUPPRESOR	1	
4	31512ZE2000	GROMMET, CORD	1	
9	90015883000	FLANGE BOLT 6X28	2	
10	90684ZA0601	CLIP, HARNESS	1	
15	32110Z5K000	HARNESS ASSY. ENGINE WIRE	1	
28	30500Z5T003	COIL ASSY. IGNITION	1	

NOTICE

◆ GX390UT2SMXC

◇ GX390UT2SCM

HONDA GX390UT2SMXC/SCM ENG. — CONTROL ASSY.

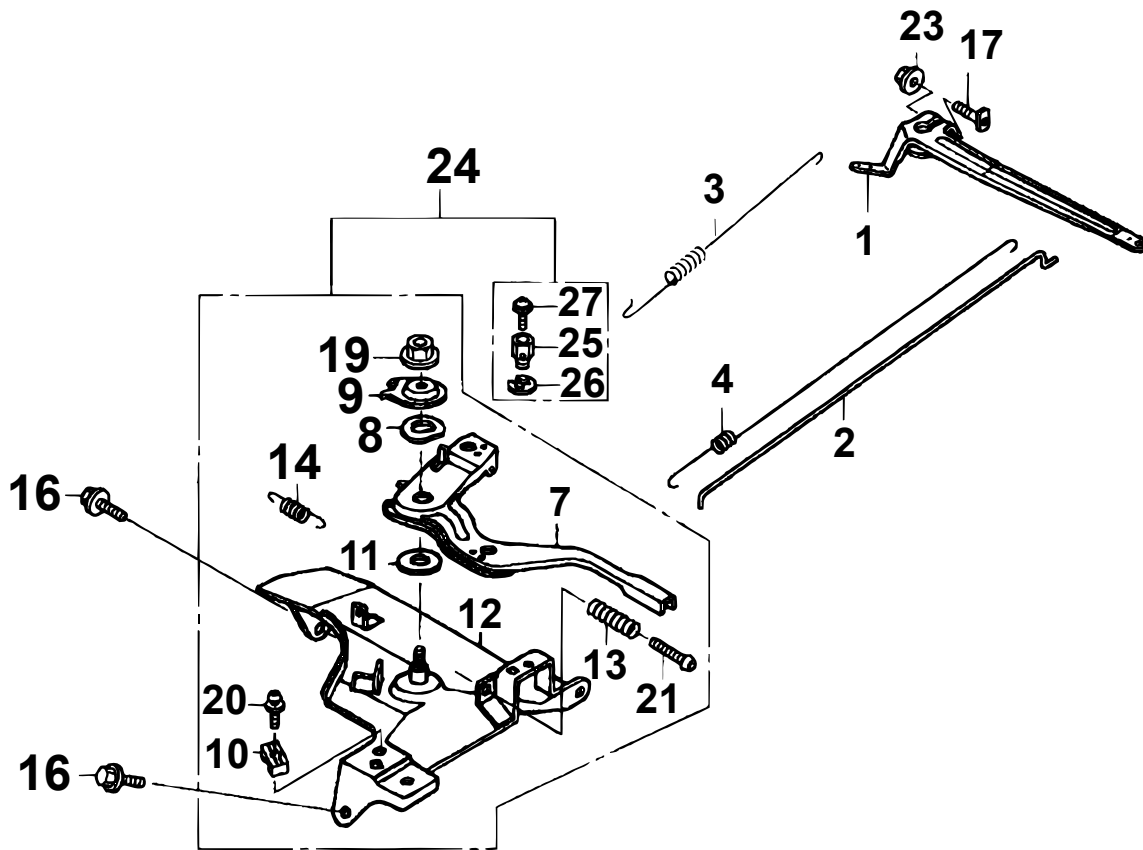

HONDA GX390UT2SMXC/SCM ENG. — CONTROL ASSY.

NO.	PART NO.	PART NAME	QTY.	REMARKS
1	16551ZE3000	ARM, GOVERNOR	1	
2	16555ZE3000	ROD, GOVERNOR	1	
3	16561ZE3000	SPRING, GOVERNOR	1	
4◆	16562ZE3000	SPRING, THROTTLE RETURN	1	
4◇	16562ZE2700	SPRING, THROTTLE RETURN	1	
7#%	16571ZE3W00	LEVER CONTROL	1	
8#%	16574ZE1000	LEVER SPRING	1	
9#%	16575ZE2W00	WASHER, CONTROL LEVER	1	
10#%	16576891000	HOLDER, CABLE	1	
11#%	16578ZE1000	SPACER, CONTROL LEVER	1	
12#%	16580Z5T000	BASE COMP., CONTROL	1	
13#%	16584883300	ADJUSTING SPRING	1	
14#%	16592883310	SPRING, CABLE RETURN	1	
16	90013883000	FLANGE BOLT 6X12	2	
17	90015Z5T000	BOLT, GOVERNOR ARM	1	
19#%	90114SA0000	LOCK NUT 6MM	1	
20#%	0202005T125	SCREW 5X16	1	REPLACES P/N 93500050160A
21#%	93500050320A	PAN SCREW 5X32	1	
23	9405006000	FLANGE NUT 6MM	1	
24◆	16500Z5T306	CONTROL ASSY., (REMOTE)	1	INCLUDES ITEMS W/#
24◇	16500Z5T800	CONTROL ASSY., (REMOTE)	1	INCLUDES ITEMS W/%
25#%	16594883010	HOLDER, WIRE	1	
26#%	90605230000	CIR CLIP	1	
27#%	0043504060	SCREW 4X6	1	REPLACES P/N 93500040060H

NOTICE

- ◆ GX390UT2SMXC
- ◇ GX390UT2SCM

HONDA GX390UT2SMXC/SCM ENG. — ENGINE DECAL ASSY.

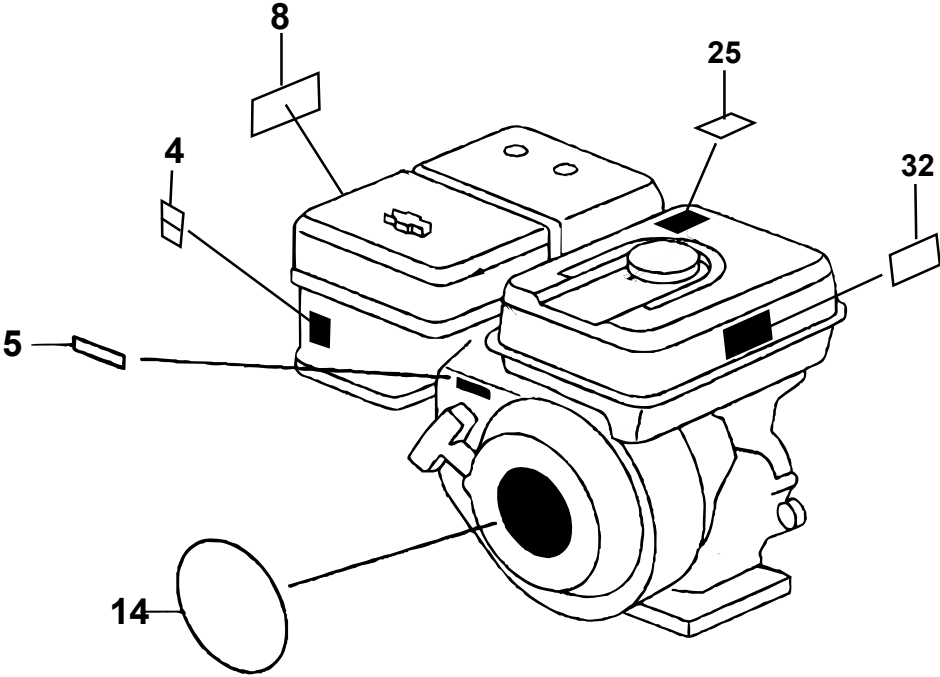

HONDA GX390UT2SMXC/SCM ENG. — ENGINE DECAL ASSY.

<u>NO.</u>	<u>PART NO.</u>	<u>PART NAME</u>	<u>QTY.</u>	<u>REMARKS</u>
4◆	87528Z5T000	MARK, CHOKE (GRAY)	1	
4◇	87528Z4M000	MARK, CHOKE	1	
5	87532ZH7000	MARK, THROTTLE INDICATION	1	
8◆	87535ZE1841	MARK, AIR CLEANER	1	
14	87521Z5T000	EMBLEM	1	
25	87539Z0J000	MARK, EX, CAUTION/ENGLISH	1	
32	87516Z4H010	MARK, OP-CAUTION/ENGLISH	1	

NOTICE

◆ GX390UT2SMXC

◇ GX390UT2SCM