

PARTS MANUAL



Mikasa SERIES
MODEL MVC88VTH
MODEL MVC88VTHW
ONE-WAY PLATE COMPACTOR
**(HONDA GX160UT2QMX2/GX160UT2QMXC/
GX160UT2QCM GASOLINE ENGINES)**

Revision #10 (06/09/20)

THIS MANUAL MUST ACCOMPANY THE EQUIPMENT AT ALL TIMES.

TABLE OF CONTENTS

MVC88VTH/MVC88VTHW Plate Compactor

Explanation Of Code In Remarks Column.....	4
Suggested Spare Parts	5

Compactor Component Drawings

Body Assembly	6–11
Vibrator Plate/Case Assembly.....	12–13
Transport Wheel Assembly (Option).....	14–15
Sprinkler Assembly.....	16–17
Urethane Plate Assembly (Option).....	18–19
Nameplate And Decals Assembly	20–21

Honda GX160UT2QMX2, GX160UT2QMXC and GX160UT2QCM Engines

Engine Component Drawings

Cylinder Head Assembly	22–23
Cylinder Barrel Assembly	24–25
Crankcase Cover Assembly	26–27
Crankshaft Assembly.....	28–29
Piston Assembly.....	30–31
Camshaft Assembly.....	32–33
Recoil Starter Assembly	34–35
Fan Cover Assembly.....	36–37
Carburetor Assembly.....	38–39
Air Cleaner Assembly (GX160UT2QMX2)	40–41
Air Cleaner Assembly (GX160UT2QMXC).....	42–43
Air Cleaner Assembly (GX160UT2QCM)	44–45
Muffler Assembly	46–47
Fuel Tank Assembly.....	48–49
Flywheel Assembly	50–51
Ignition Coil Assembly (GX160UT2QMX2/QMXC)..	52–53
Ignition Coil Assembly (GX160UT2QCM)	54–55
Control Assembly	56–57
Engine Decals Assembly	58–59

NOTICE

Specifications and part numbers are subject to change without notice.

EXPLANATION OF CODE IN REMARKS COLUMN

The following section explains the different symbols and remarks used in the Parts section of this manual. Use the help numbers found on the back page of the manual if there are any questions.

NOTICE

The contents and part numbers listed in the parts section are subject to change **without notice**. Multiquip does not guarantee the availability of the parts listed.

SAMPLE PARTS LIST

NO.	PART NO.	PART NAME	QTY.	REMARKS
1	12345	BOLT	1	INCLUDES ITEMS W/%
2%		WASHER, 1/4 IN.		NOT SOLD SEPARATELY
2%	12347	WASHER, 3/8 IN. ...	1	MQ-45T ONLY
3	12348	HOSE	A/R	MAKE LOCALLY
4	12349	BEARING	1	S/N 2345B AND ABOVE

NO. Column

Unique Symbols — All items with same unique symbol (@, #, +, %, or >) in the number column belong to the same assembly or kit, which is indicated by a note in the “Remarks” column.

Duplicate Item Numbers — Duplicate numbers indicate multiple part numbers, which are in effect for the same general item, such as different size saw blade guards in use or a part that has been updated on newer versions of the same machine.

NOTICE

When ordering a part that has more than one item number listed, check the remarks column for help in determining the proper part to order.

PART NO. Column

Numbers Used — Part numbers can be indicated by a number, a blank entry, or TBD.

TBD (To Be Determined) is generally used to show a part that has not been assigned a formal part number at the time of publication.

A blank entry generally indicates that the item is not sold separately or is not sold by Multiquip. Other entries will be clarified in the “Remarks” Column.

QTY. Column

Numbers Used — Item quantity can be indicated by a number, a blank entry, or A/R.

A/R (As Required) is generally used for hoses or other parts that are sold in bulk and cut to length.

A blank entry generally indicates that the item is not sold separately. Other entries will be clarified in the “Remarks” Column.

REMARKS Column

Some of the most common notes found in the “Remarks” Column are listed below. Other additional notes needed to describe the item can also be shown.

Assembly/Kit — All items on the parts list with the same unique symbol will be included when this item is purchased.

Indicated by:
 “INCLUDES ITEMS W/(unique symbol)”

Serial Number Break — Used to list an effective serial number range where a particular part is used.

Indicated by:
 “S/N XXXXX AND BELOW”
 “S/N XXXX AND ABOVE”
 “S/N XXXX TO S/N XXX”

Specific Model Number Use — Indicates that the part is used only with the specific model number or model number variant listed. It can also be used to show a part is NOT used on a specific model or model number variant.

Indicated by:
 “XXXXX ONLY”
 “NOT USED ON XXXX”

“Make/Obtain Locally” — Indicates that the part can be purchased at any hardware shop or made out of available items. Examples include battery cables, shims, and certain washers and nuts.

“Not Sold Separately” — Indicates that an item cannot be purchased as a separate item and is either part of an assembly/kit that can be purchased, or is not available for sale through Multiquip.

SUGGESTED SPARE PARTS

MVC88VTH/MVC88VTWH PLATE COMPACTOR WITH HONDA GX160UT2QMX2/GX160UT2QMXC/GX160UT2QCM GASOLINE ENGINES

1 to 5 units

Qty.	P/N	Description
3	070100332	V-BELT, RPF3330
5◆◆	0650140480	SPARK PLUG, EY45V
5◆	9807956846	SPARK PLUG, BPR6ES
1	28462ZH8003	ROPE, RECOIL STARTER
5◆◆	17210ZE1517	ELEMENT, AIR CLEANER
5◆	17210Z0V781	ELEMENT, AIR CLEANER
1◆	17620Z4H030	CAP COMPLETE, FUEL TANK
1◆◆	17620Z4H900	CAP COMPLETE, FUEL TANK
1	17672Z4H000	FUEL FILTER, FUEL TANK
4	939010230	SHOCK ABSORBER

NOTICE

- ◆ GX160UT2QMX2
- ◇ GX160UT2QMXC
- ◆ GX160UT2QCM

NOTICE

Part numbers on this Suggested Spare Parts list may supersede/replace the part numbers shown in the following parts lists.

BODY ASSY.

S/N B1001 ~ B6084, S/N C6085 ~ C9999,
S/N C1001 ~ C1152, S/N C1253 ~ C1471

S/N C1153 ~ C1252,
S/N C1472 AND ABOVE

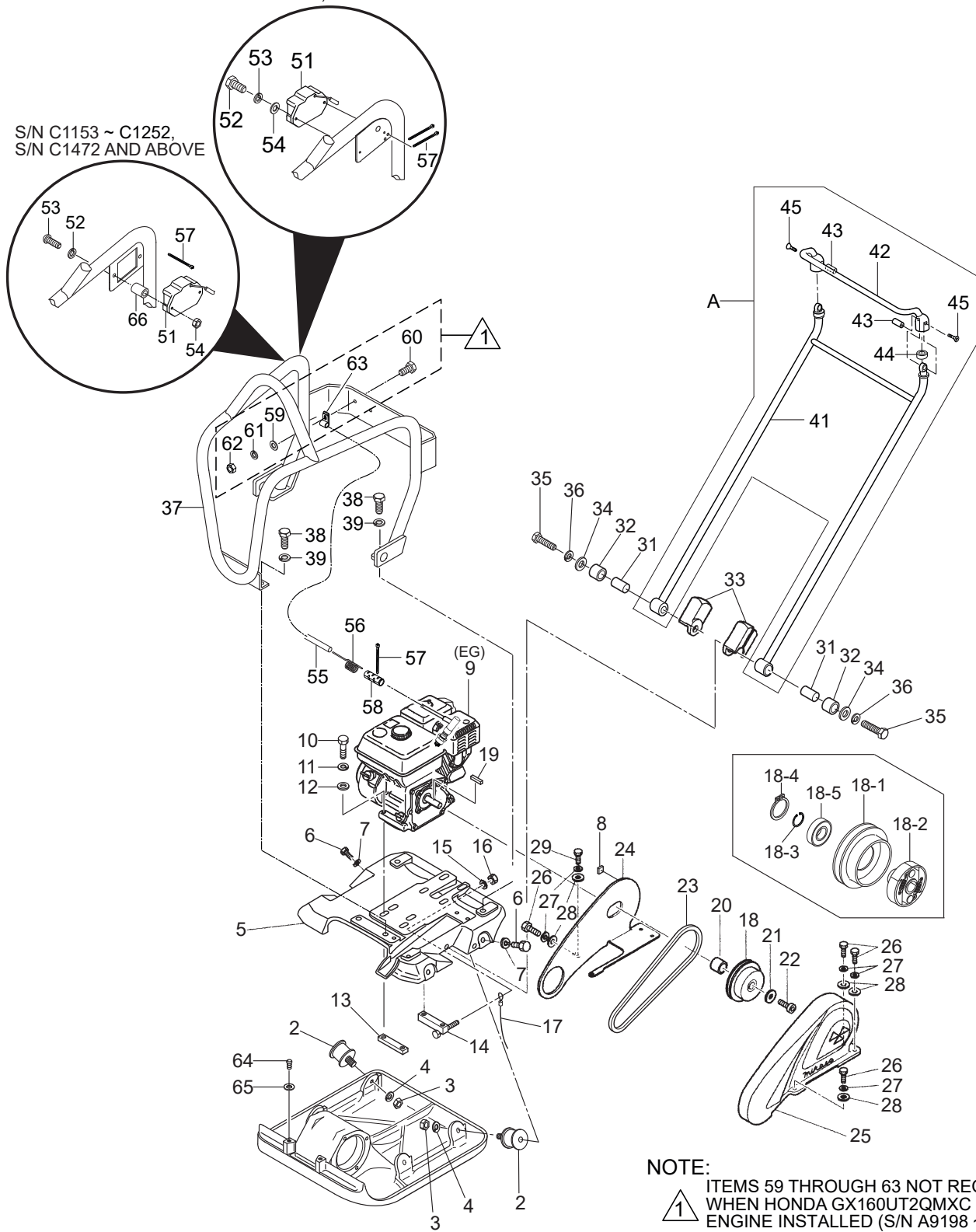

NOTE:



ITEMS 59 THROUGH 63 NOT REQUIRED
WHEN HONDA GX160UT2QMXC
ENGINE INSTALLED (S/N A9198 ~ A9999,
S/N A1001 ~ A3342, S/N B1001 ~ B6084,
S/N C6085 ~ C9999, S/N C1001 ~ C1152,
S/N C1253 ~ C1471).

BODY ASSY.

<u>NO.</u>	<u>PART NO.</u>	<u>PART NAME</u>	<u>QTY.</u>	<u>REMARKS</u>
A	416910120	HANDLE ASSY.	1.....	INCLUDES ITEMS W/%
2	939010230	SHOCK ABSORBER	4	
3	020310080	NUT M10	4	
4	030210250	WASHER, LOCK M10	4	
5	416120390	BASE	1	
6	001221025	BOLT 10X25	4	
7	030210250	WASHER, LOCK M10	4	
8	416454360	RUBBER PLATE 25X25X8	1	
9	912216015	ENGINE ASSY.,GX160UT2QMX2.....	1.....	S/N A9197 AND BELOW
9	912216021	ENGINE ASSY.,GX160UT2QMXC	1.....	S/N A9198 ~ A9999 S/N A1001 ~ A3342 S/N B1001 ~ B6084 S/N C6085 ~ C9999 S/N C1001 ~ C1152 S/N C1253 ~ C1471
9	912216025	ENGINE ASSY.,GX160UT2QCM.....		S/N C1153 ~ C1252 S/N C1472 AND ABOVE
10	001220850	BOLT 8X50	4	
11	030208200	WASHER, LOCK M8	4	
12	031108160	WASHER, FLAT M8	4	
13	416466520	ENGINE NUT	1	
14	416466540	ENGINE NUT	1	
15	031108160	WASHER, FLAT M8	1	
16	022710809	NYLON NUT M8	1	
17	959404350	EARTH WIRE, 1"	1	
18	416910100	CLUTCH ASSY	1	
18-1	416464490	CLUTCH DRUM, 1"	1	
18-2	416351320	CLUTCH SHOE AND BOSS ASSY.	1	
18-3	080200300	STOP RING, S30	1	
18-4	080600550	STOP RING, AR55	1	
18-5	042006006	BEARING 6006	1	
19	90745ZE1600	KEY 4.78X4.78X38	1	
20	416452809	COLLAR	1	
21	952400130	WASHER	1	
22	009110004	SOCKET HEAD BOLT 5/16"	1	
23	070100332	V-BELT RPF3330	1	
24	416120950	BELT COVER, INNER	1	
25	416010040	BELT COVER, OUTER	1	
26	001220825	BOLT 8X25	4	
27	030208200	WASHER, LOCK M8	5	
28	031108160	WASHER, FLAT M8	5	
29	001220820	BOLT 8X20	1	
31	952408710	COLLAR 13X20X44	2	
32	404433430	RUBBER 20X32X28	2	
33	416452360	HANDLE STOPPER	2	
34	952405600	WASHER 12.5X35X4.5	2	

BODY ASSY. (CONTINUED)

S/N B1001 ~ B6084, S/N C6085 ~ C9999,
S/N C1001 ~ C1152, S/N C1253 ~ C1471

S/N C1153 ~ C1252,
S/N C1472 AND ABOVE

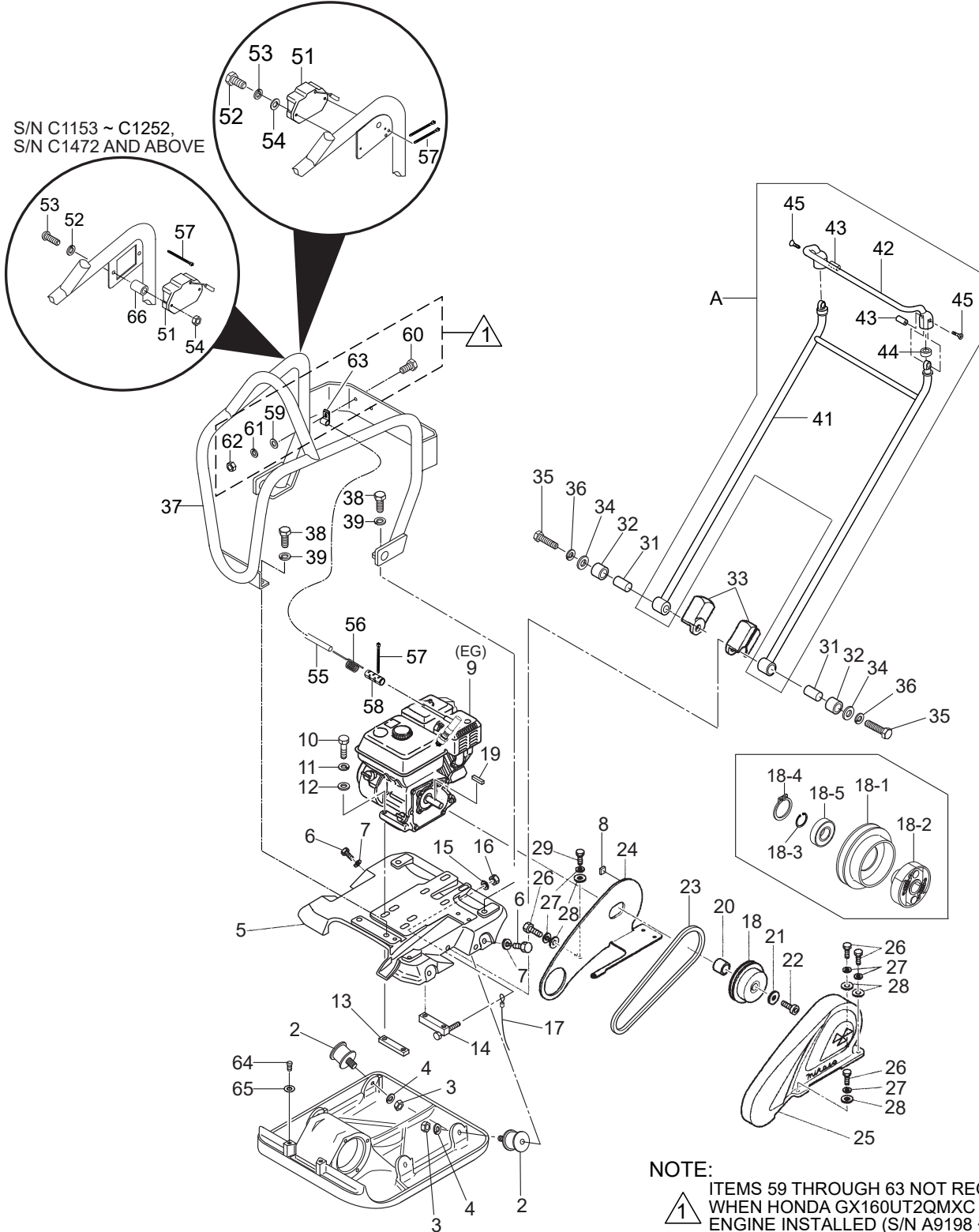

NOTE:



ITEMS 59 THROUGH 63 NOT REQUIRED
WHEN HONDA GX160UT2QMXC
ENGINE INSTALLED (S/N A9198 ~ A9999,
S/N A1001 ~ A3342, S/N B1001 ~ B6084,
S/N C6085 ~ C9999, S/N C1001 ~ C1152,
S/N C1253 ~ C1471).

BODY ASSY. (CONTINUED)

<u>NO.</u>	<u>PART NO.</u>	<u>PART NAME</u>	<u>QTY.</u>	<u>REMARKS</u>
35	001221253	BOLT 12X65	2	
36	030212300	WASHER, LOCK M12	2	
37	416121050	GUARD HOOK	1.....	S/N A9197 AND BELOW
37	416121740	GUARD HOOK	1.....	S/N A9198 ~ A9999 S/N A1001 ~ A3342 S/N B1001 ~ B6084 S/N C6085 ~ C9999 S/N C1001 ~ C1152 S/N C1253 ~ C1471
37	416121051	GUARD HOOK	1.....	S/N C1153 ~ C1252 S/N C1472 AND ABOVE
38	0105091025	BOLT 10X25	4	
39	030210250	WASHER, LOCK M10	4	
41%	416121010	VAS HANDLE BODY	1	
42%	416218770	GRIP, VAS HANDLE	1	
43%	416459320	HANDLE NUT, VAS HANDLE	2	
44%	416459340	RUBBER, VAS HANDLE	2	
45%	009120407	SUNK HEAD BOLT 10X20	2	
51	955010311	TACH/HOUR METER	1	
52	001220510	BOLT 5X10.....	2.....	S/N B1001 ~ B6084 S/N C6085 ~ C9999 S/N C1001 ~ C1152 S/N C1253 ~ C1471
52	009110101	PAN HEAD SCREW 5X25	2.....	S/N C1153 ~ C1252 S/N C1472 AND ABOVE
53	030205130	WASHER, LOCK M5	2	
54	58151	WASHER, FLAT M5.....	2.....	S/N B1001 ~ B6084 S/N C6085 ~ C9999 S/N C1001 ~ C1152 S/N C1253 ~ C1471
54	020305040	NUT, M5.....	2.....	S/N C1153 ~ C1252 S/N C1472 AND ABOVE
55	959026822	RUBBER TUBE	1	
56	955010310	CURL CORD	1	
57	507010110	CLAMP.....	3.....	S/N B1001 ~ B6084 S/N C6085 ~ C9999 S/N C1001 ~ C1152 S/N C1253 ~ C1471
57	507010110	CLAMP.....	2.....	S/N C1153 ~ C1252 S/N C1472 AND ABOVE
58	955010307	CLIP BELT	1	

BODY ASSY. (CONTINUED)

S/N B1001 ~ B6084, S/N C6085 ~ C9999,
S/N C1001 ~ C1152, S/N C1253 ~ C1471

S/N C1153 ~ C1252,
S/N C1472 AND ABOVE

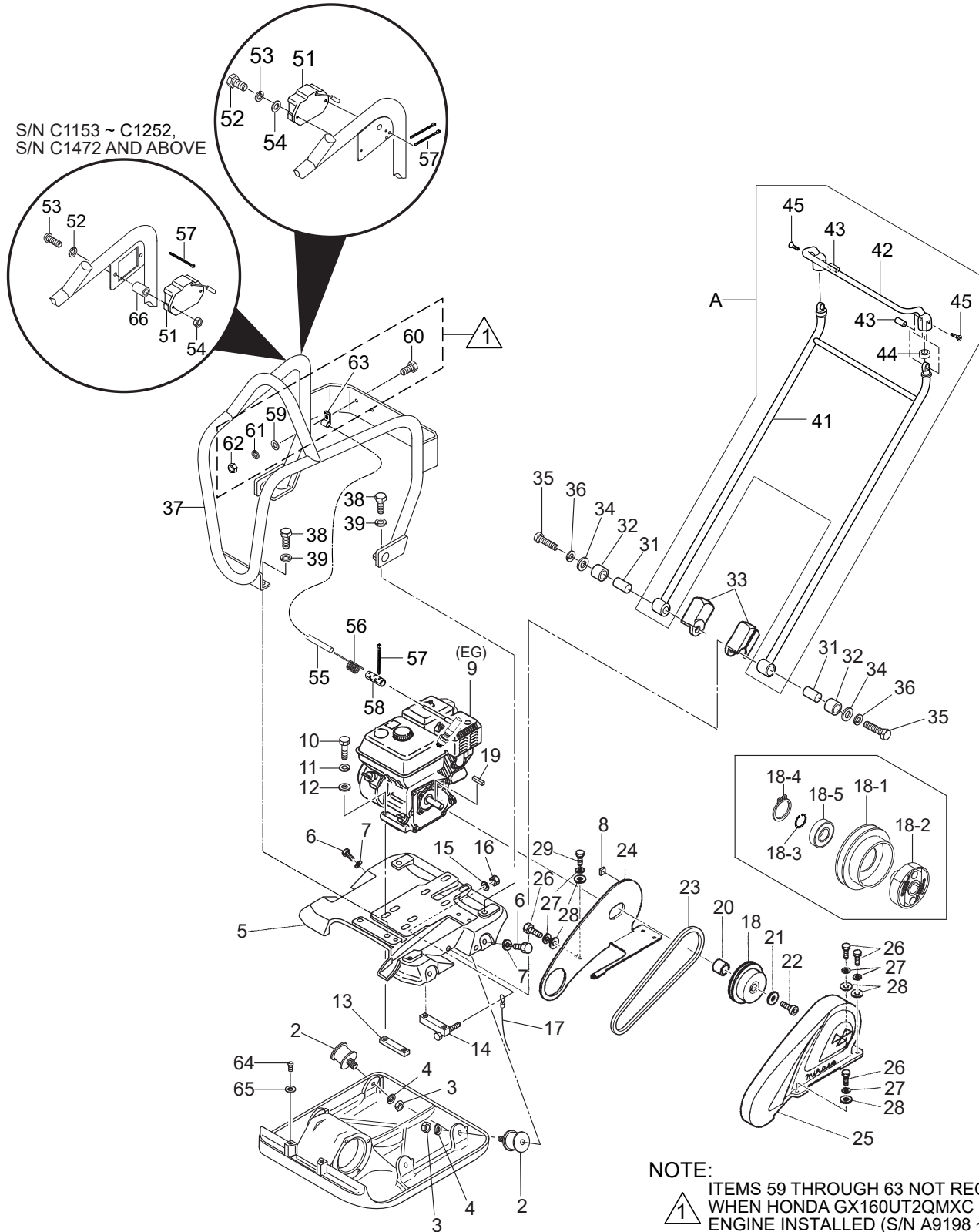

NOTE:



ITEMS 59 THROUGH 63 NOT REQUIRED
WHEN HONDA GX160UT2QMXC
ENGINE INSTALLED (S/N A9198 ~ A9999,
S/N A1001 ~ A3342, S/N B1001 ~ B6084,
S/N C6085 ~ C9999, S/N C1001 ~ C1152,
S/N C1253 ~ C1471).

BODY ASSY. (CONTINUED)

<u>NO.</u>	<u>PART NO.</u>	<u>PART NAME</u>	<u>QTY.</u>	<u>REMARKS</u>
59	952404470	WASHER, FLAT M6.....	1.....	S/N A9197 AND BELOW
60	0105050616	BOLT 6X15.....	1.....	S/N A9197 AND BELOW
61	030206150	WASHER, LOCK M6.....	1.....	S/N A9197 AND BELOW
62	020106050	NUT M6.....	1.....	S/N A9197 AND BELOW
63	2067550101	CLAMP COMPLETE.....	1.....	S/N A9197 AND BELOW
64	001221215	BOLT 12X15	2	
65	031112230	WASHER, FLAT M12	2	
66	952409910	COLLAR 6.5X10.5X12.7.....	2.....	S/N C1153 ~ C1252 S/N C1472 AND ABOVE

VIBRATOR PLATE/CASE ASSY.

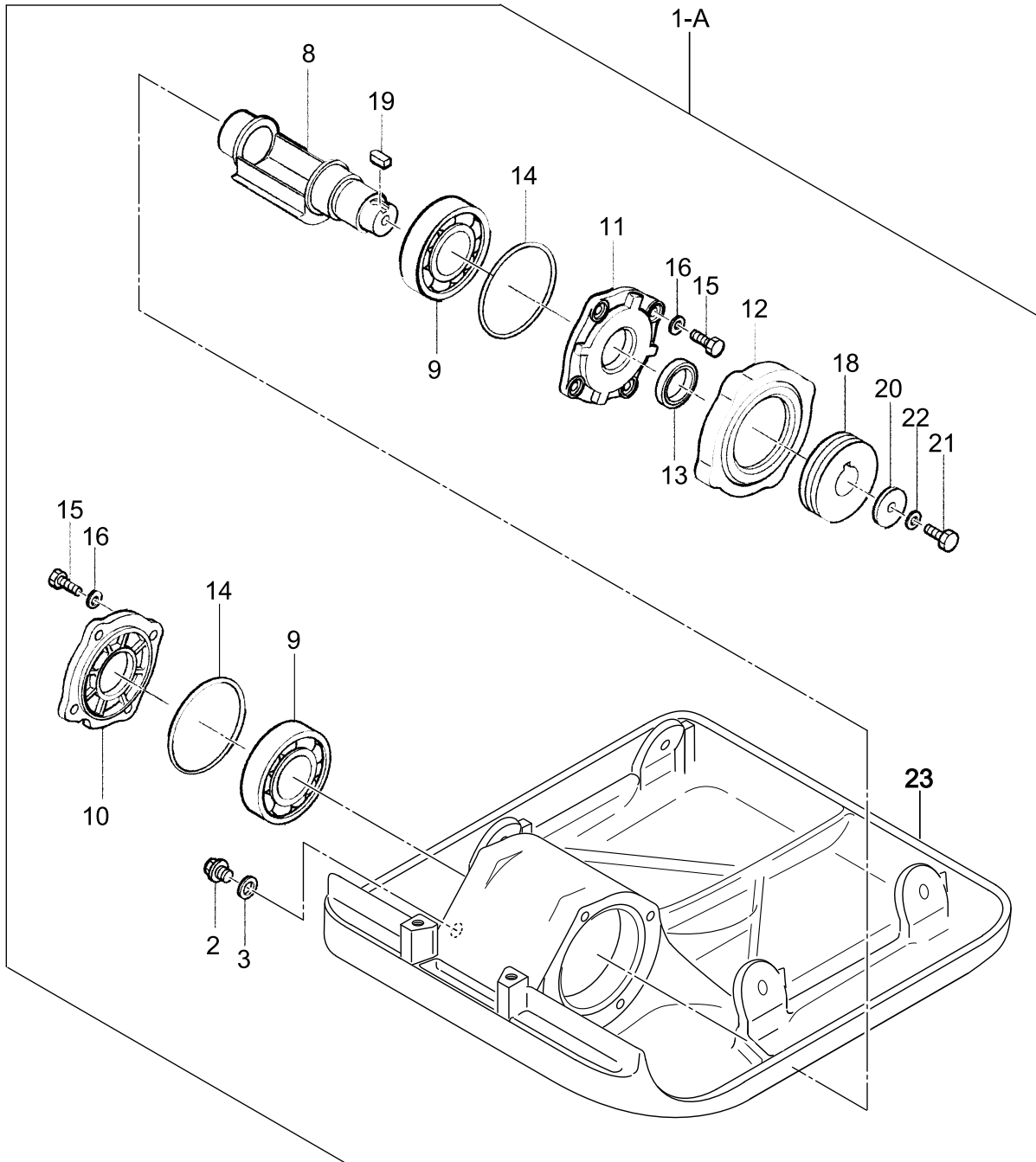

VIBRATOR PLATE/CASE ASSY.

NO.	PART NO.	PART NAME	QTY.	REMARKS
1-A	416910150	VIBRATING PLATE/CASE ASSY.....	1.....	INCLUDES ITEMS W/#
2#	953405270	PLUG 1/4X14 X13L	1	
3#	953405260	PACKING 1/4"	1	
8#	416218390	ECCENTRIC ROTATOR	1	
9#	040406211	BEARING 6211C4	2	
10#	416338909	CASE COVER (R)	1	
11#	416338919	CASE COVER (L)	1	
12#	416349930	BELT COVER GUARD	1	
13#	060403060	OIL SEAL, TC35488	1	
14#	050101000	O-RING	2	
15#	014208020	BOLT 8X20	8	
16#	030208200	WASHER, LOCK M8	8	
18#	416464470	PULLEY, VIBRATOR ASSY.	1	
19#	951405240	KEY 7X7X19	1	
20#	952404250	WASHER 11X40X4	1	
21#	0105091025	BOLT 10X25	1	
22#	030210250	WASHER, LOCK M10	1	
23#	416120141	VIBRATING PLATE	1	

TRANSPORT WHEEL ASSY. (OPTION)

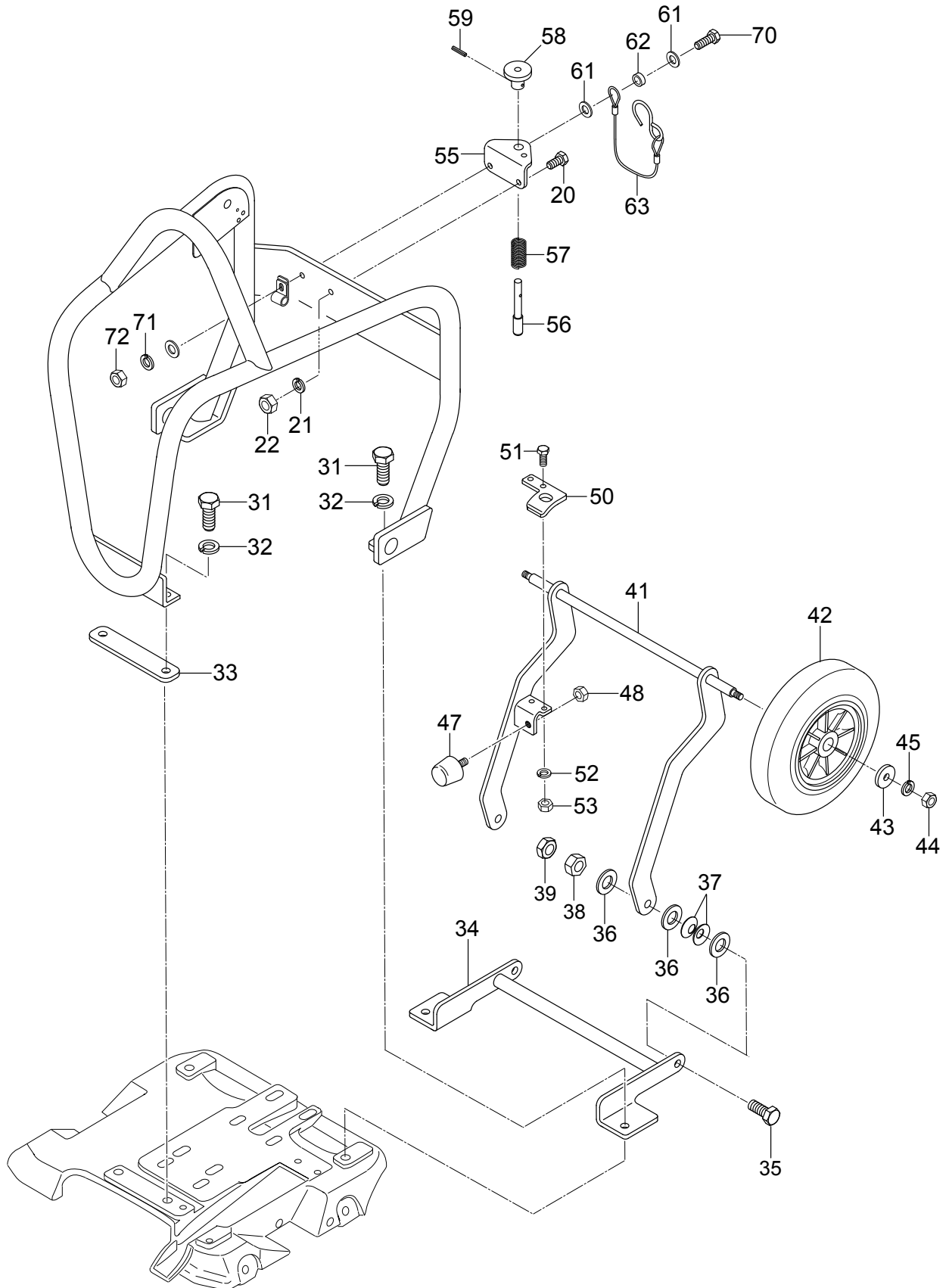

TRANSPORT WHEEL ASSY. (OPTION)

<u>NO.</u>	<u>PART NO.</u>	<u>PART NAME</u>	<u>QTY.</u>	<u>REMARKS</u>
20	0105050616	BOLT 6X15	1	
21	030206150	WASHER, LOCK M6	1	
22	020106050	NUT M6	1	
31	012010030	BOLT 10X30	4	
32	030210250	WASHER, LOCK M10	4	
33	416466680	SPACER, WHEEL	1	
34	416352490	BRACKET, WHEEL	1	
35	012210035	BOLT 10X35	2	
36	031110160	WASHER, FLAT M10	6	
37	032110180	CONICAL LOCK WASHER	4	
38	020310080	NUT M10	2	
39	020310080	NUT M10	2	
41	416218830	AXLE, TRANSPORT WHEEL, WHL88T	1	S/N A9197 ~ BELOW
41	416219520	AXLE, TRANSPORT WHEEL, WHL88TC.....	1	S/N AND A9198 ~ C1471
41	416218830	AXLE, TRANSPORT WHEEL, WHL88T	1	S/N C1472 AND ABOVE
42	959301000	WHEEL	2	
43	952400130	SPACER	2	
44	020108060	NUT M8	2	
45	030208200	WASHER, LOCK M8	2	
47	939010270	STOPPER RUBBER	1	
48	020108060	NUT M8	1	
50	416467230	STOPPER, LOCK PIN	1	
51	011206020	BOLT 6X20	2	
52	030206150	WASHER, LOCK M6	2	
53	020106050	NUT M6	2	
55	416351700	LOCK BRACKET, WHEEL	1	
56	416466690	LOCK PIN, WHEEL	1	
57	458450880	SPRING	1	
58	416467240	LOCK KNOB, WHEEL	1	
59	025403016	SPRING PIN 3X16	1	
61	952408960	WASHER, FLAT 6.5X16X1	2	
62	952408980	COLLAR 6.2X9X4	1	
63	419466670	LOCK WIRE, HANDLE	1	
70	011606025	BOLT 6X25	1	
71	030206150	WASHER, LOCK M6	1	
72	020106050	NUT M6	1	

SPRINKLER ASSY.

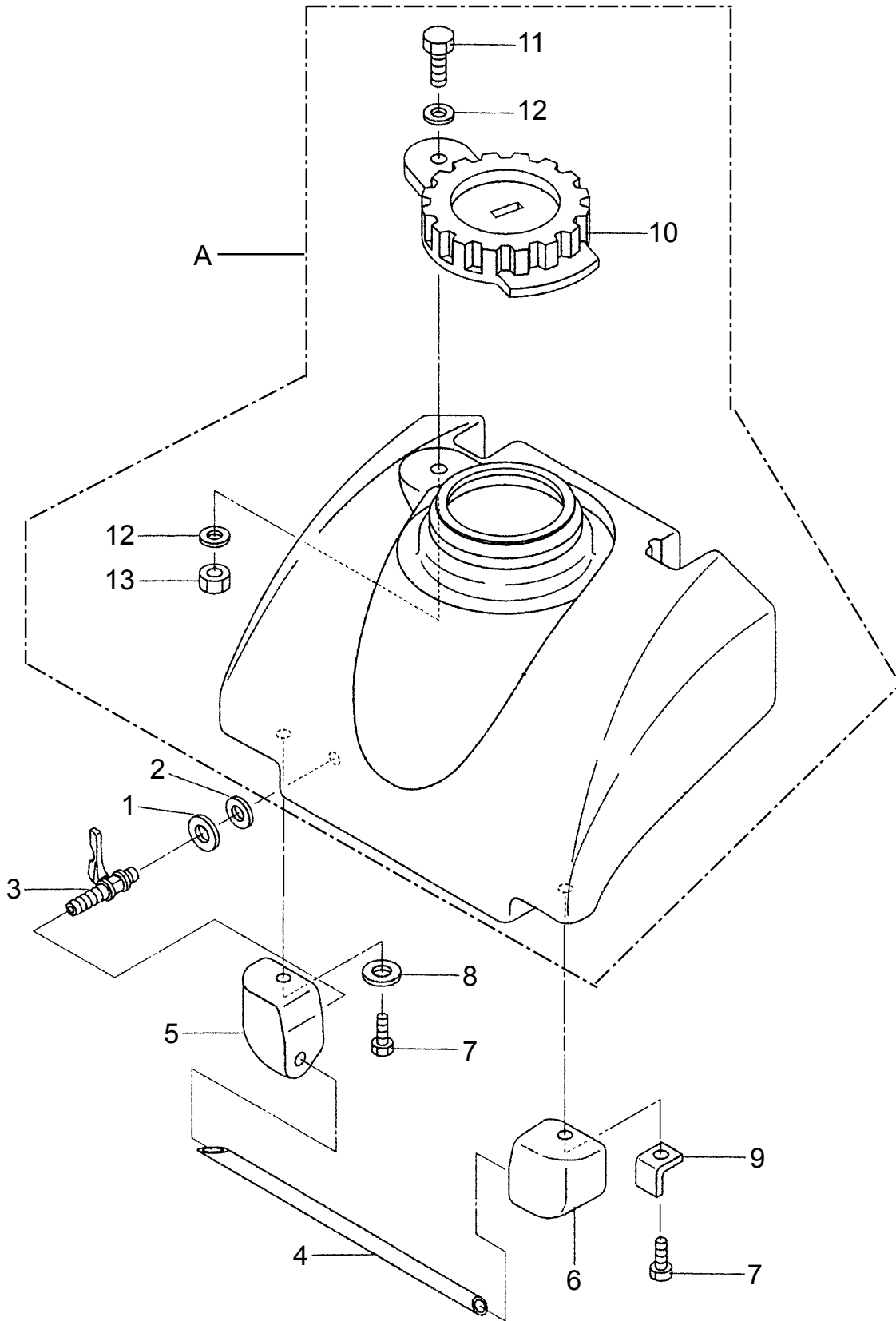

SPRINKLER ASSY.

<u>NO.</u>	<u>PART NO.</u>	<u>PART NAME</u>	<u>QTY.</u>	<u>REMARKS</u>
A	416910110	WATER TANK W/CAP	1.....	INCLUDES ITEMS W/%
1	033910050	WASHER 14.5X30X1.6	1	
2	953406390	PACKING 13X28X2	1	
3	954403241	COCK PT 1/4"	1	
4	416338930	SPRINKLING PIPE	1	
5	416338940	PIPE HOLDER (L)	1	
6	416452750	PIPE HOLDER (R)	1	
7	001220825	BOLT 8X25	2	
8	0401450080	WASHER, FLAT M8	1	
9	416452790	STAY, PIPE HOLDER	1	
10%	954300342	CAP, WATER TANK	1	
11%	001241030	BOLT 10X30	1	
12%	033910160	WASHER, FLAT M10	2	
13%	022910270	NUT M10	1	

URETHANE PLATE ASSY. (OPTION)

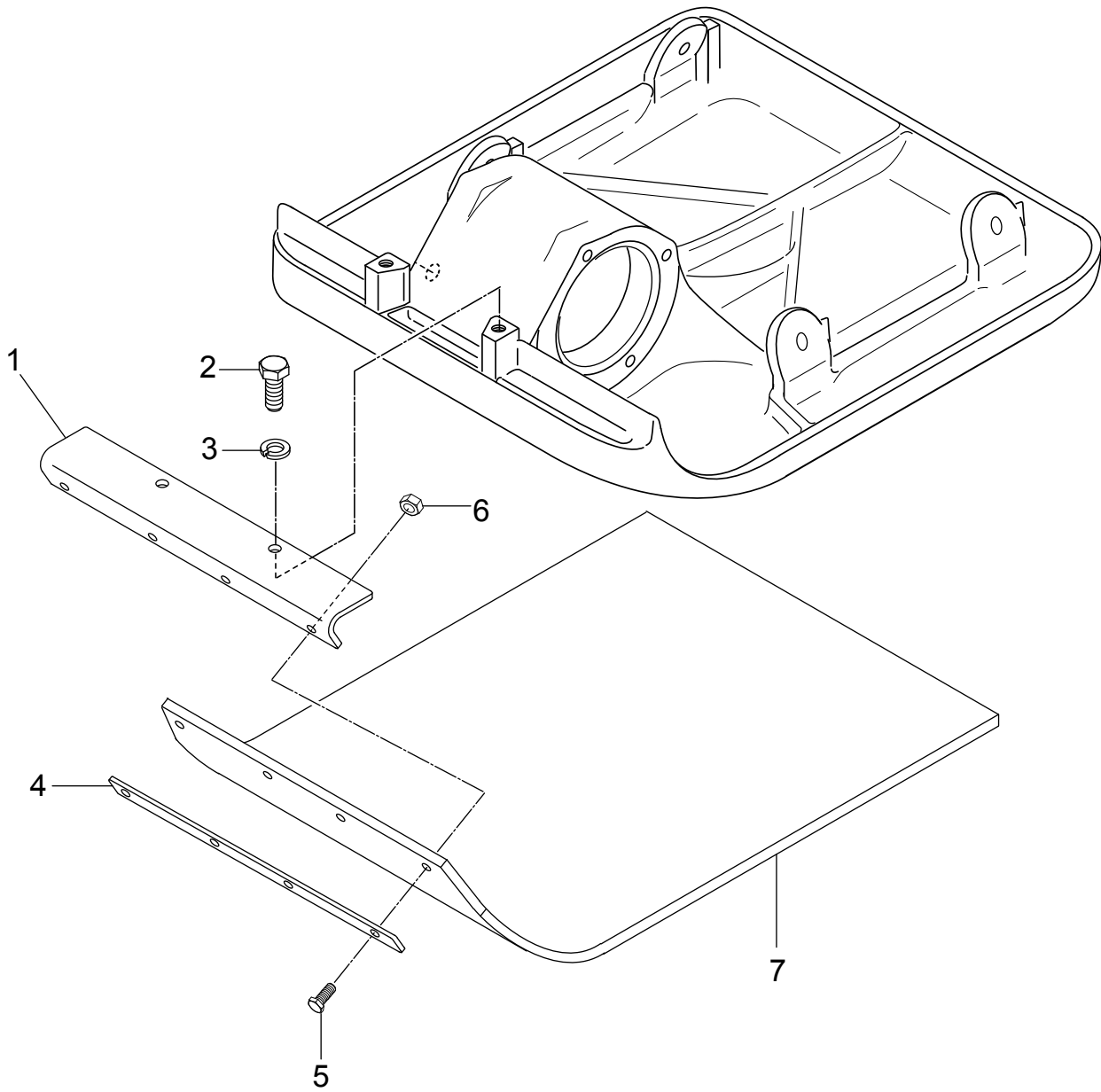

URETHANE PLATE ASSY. (OPTION)

<u>NO.</u>	<u>PART NO.</u>	<u>PART NAME</u>	<u>QTY.</u>	<u>REMARKS</u>
1	416352080	HANGER, URETHANE PLATE	1	
2	001221230	BOLT 12X30	2	
3	012012030	WASHER, LOCK M12	2	
4	416352090	PLATE, URETHANE PLATE	1	
5	011208035	BOLT 8X35	4	
6	022710809	NYLON NUT M8	4	
7	PADUPA88	PAD, URETHANE	1.....	REPLACES P/N 416342390

NAMEPLATE AND DECALS ASSY.

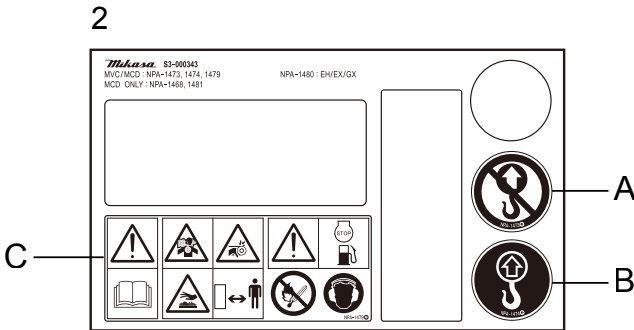
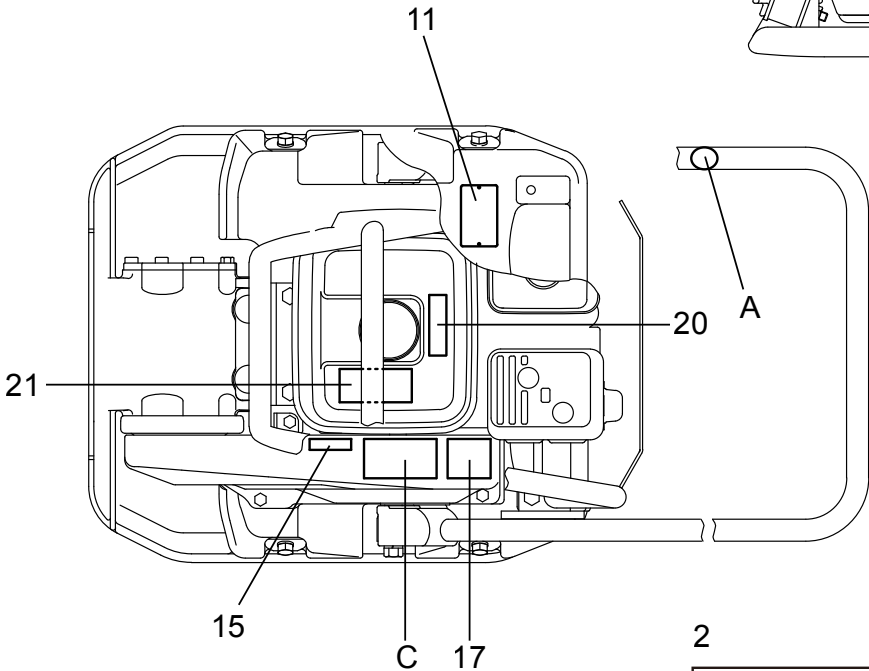
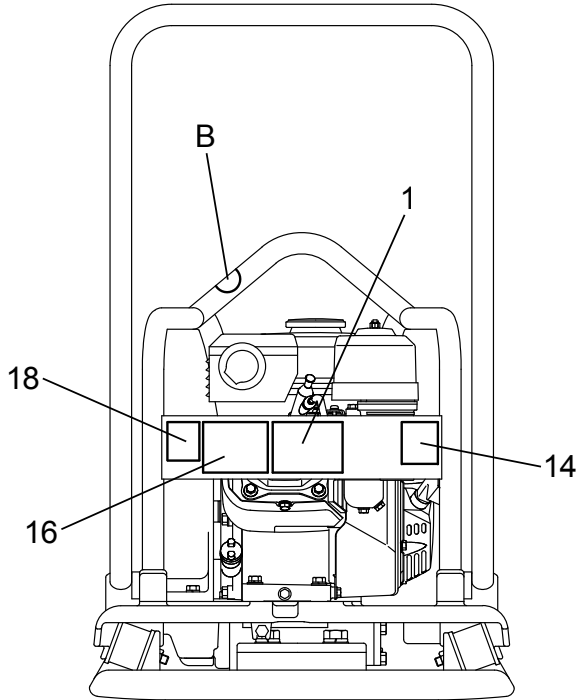
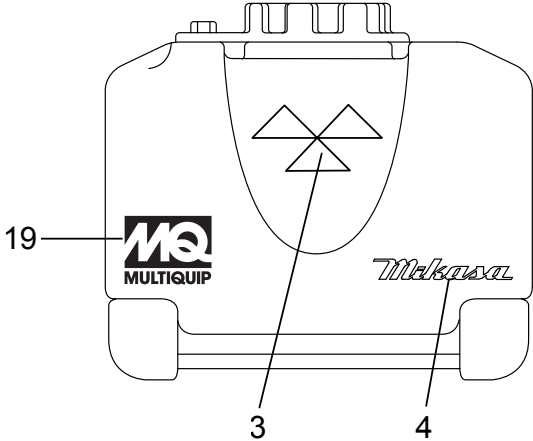

NAMEPLATE AND DECALS ASSY.

<u>NO.</u>	<u>PART NO.</u>	<u>PART NAME</u>	<u>QTY.</u>	<u>REMARKS</u>
1	920218170	DECAL, POSITION	1	
2	920900090	DECAL, SET	1.....	SET ONLY
3	920101410	DECAL, MIKASA MARK 120X60	1	
4	920105070	DECAL, MIKASA MARK 125MM	1	
11	920217430	PLATE, SERIAL NO./88VTH	1	
11	920217440	PLATE, SERIAL NO./88VTHW	1	
14	920210330	DECAL, EC NOISE REQ.LWA105	1	
15	920208350	DECAL, V-BELT RPF3330	1	
16	920203290	DECAL, CAUTION	1	
17	920203060	DECAL, CAUTION	1	
18	920206290	DECAL, CAUTION (MANUAL/EXP)	1	
19	920201580	DECAL, MQ MARK 71X55	1	
20	920214100	DECAL, E/G FIRE WARNING	1	
21	920212320	DECAL, FUEL CAUTION	1	

HONDA GX160UT2 SERIES ENG. — CYLINDER HEAD ASSY.

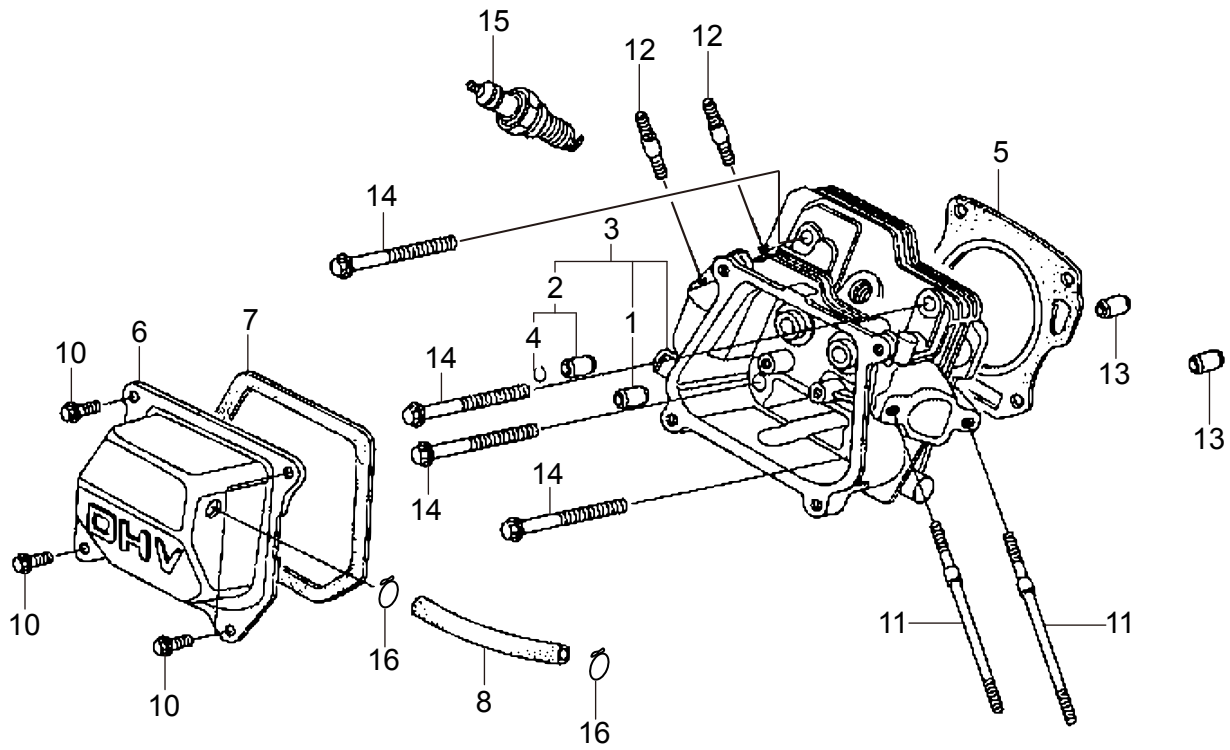

HONDA GX160UT2 SERIES ENG. — CYLINDER HEAD ASSY.

NO.	PART NO.	PART NAME	QTY.	REMARKS
1%	12204ZE1306	GUIDE, INLET VALVE (O.S.)	1	
2%	12205ZE1315	GUIDE, EXHAUST VALVE (O. S.).....	1	INCLUDES ITEM W/\$
3	12210Z4M405	HEAD COMPLETE, CYLINDER.....	1	INCLUDES ITEMS W/%
4\$%	12216ZE5300	CLIP, VALVE GUIDE	1	
5	12251ZL0003	GASKET, CYLINDER HEAD	1	
6◆	12310Z4M000	COVER COMPLETE, HEAD	1	
6◇	12310Z4M840	COVER COMPLETE, HEAD	1	
7	12391ZE1000	PACKING, HEAD COVER	1	
8◆	15721ZH8000	TUBE, BREATHER	1	
8◇	15721ZH1840	TUBE, BREATHER	1	
8●	15721ZE1840	TUBE, BREATHER	1	
10	90013883000	FLANGE BOLT 6X12	4	
11	90043ZE1020	STUD BOLT 6X112	2	
12	90047ZE1000	STUD BOLT 8X32	2	
13	9430110160	KNOCK PIN 10X16	2	
14	957010806000	BOLT, FLANGE 8X60	4	
15◆◇	0650140480	SPARK PLUG, EY45V	1	
15●	9807956846	SPARK PLUG, BPR6ES	1	REPLACES P/N 9807956876
16◇	9500280000	CLIP, TUBE	2	

NOTICE

- ◆ GX160UT2QMX2
- ◇ GX160UT2QMXC
- GX160UT2QCM

HONDA GX160UT2 SERIES ENG. — CYL. BARREL ASSY.

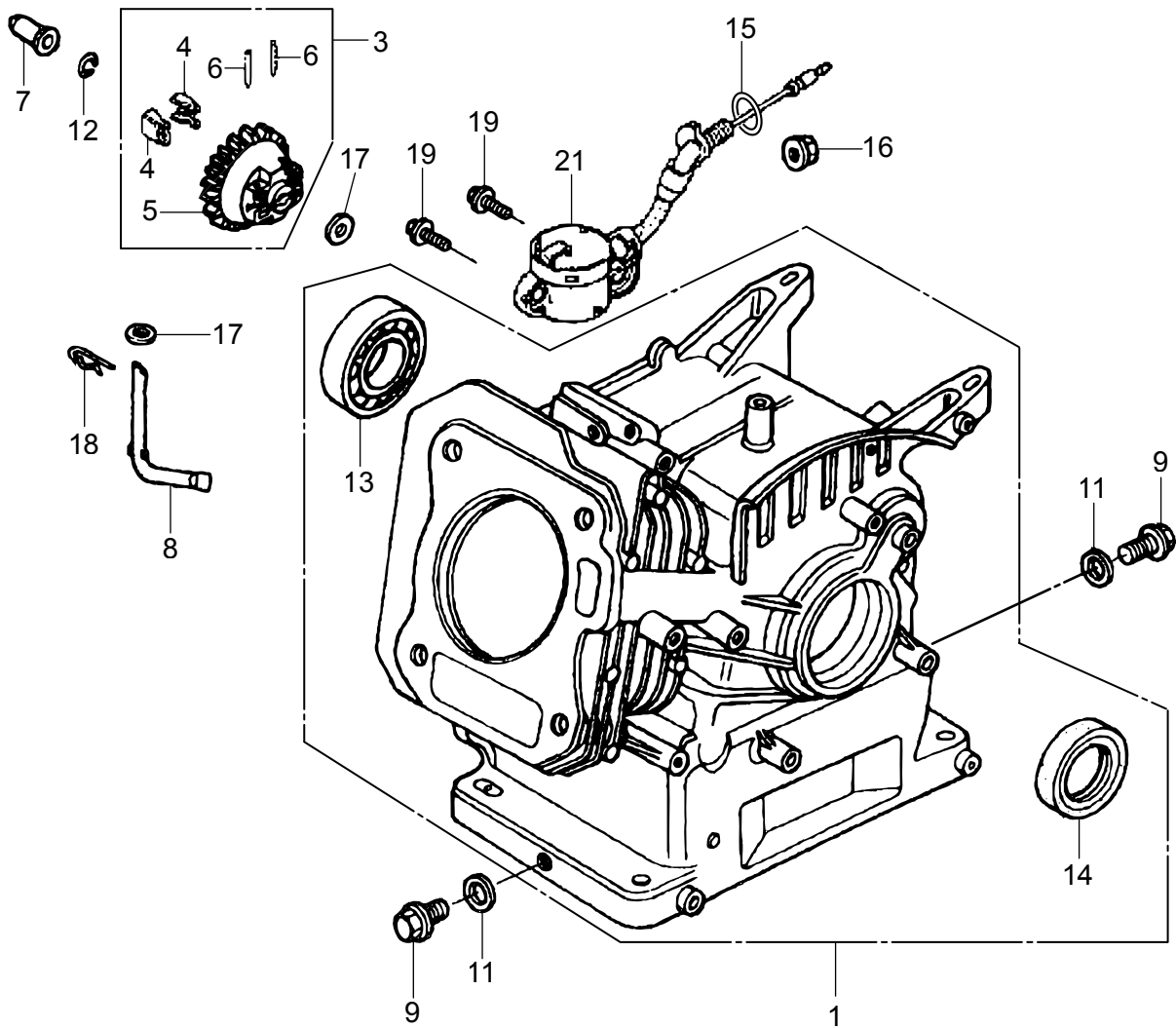

HONDA GX160UT2 SERIES ENG. — CYL. BARREL ASSY.

NO.	PART NO.	PART NAME	QTY.	REMARKS
1◆	12000Z4M406	BARREL, ASSY CYLINDER (OIL ALERT)	1	INCLUDES ITEMS W/\$
1◇	12000Z4M416	BARREL, ASSY CYLINDER (OIL ALERT)	1	INCLUDES ITEMS W/\$
3	16510Z4M000	GOVERNOR ASSY.	1	INCLUDES ITEMS W/%
4%	16511Z4M000	WEIGHT, GOVERNOR	2	
5%	16512Z4M000	HOLDER, GOVERNOR WEIGHT	1	
6%	16513ZE1000	PIN, GOVERNOR WEIGHT	2	
7	16531Z4M000	SLIDER, GOVERNOR	1	
8	16541Z4M000	SHAFT, GOVERNOR ARM	1	
9	90131ZE1000	BOLT, DRAIN PLUG	2	
11	90601ZE1000	WASHER, DRAIN PLUG	2	
12	90602ZE1000	CLIP, GOVERNOR HOLDER	1	
13\$	91001ZF1003	BALL BEARING 6205	1	
14\$	91201Z0T801	OIL SEAL 25X41X6	1	
15	91353671003	O-RING 14MM	1	REPLACES P/N 91353671004
16	9405010000	FLANGE NUT M10	1	
17	9410106800	WASHER, FLAT 6MM	2	
18	9425108000	LOCK PIN 8MM	1	
19	957010601200	FLANGE BOLT 6X12	2	
21	35480Z0T003	SWITCH ASSY., OIL LEVEL	1	

NOTICE

- ◆ GX160UT2QMX2
- ◇ GX160UT2QMXC
- ▷ GX160UT2QCM

HONDA GX160UT2 SERIES ENG. — CRANKCASE COVER ASSY.

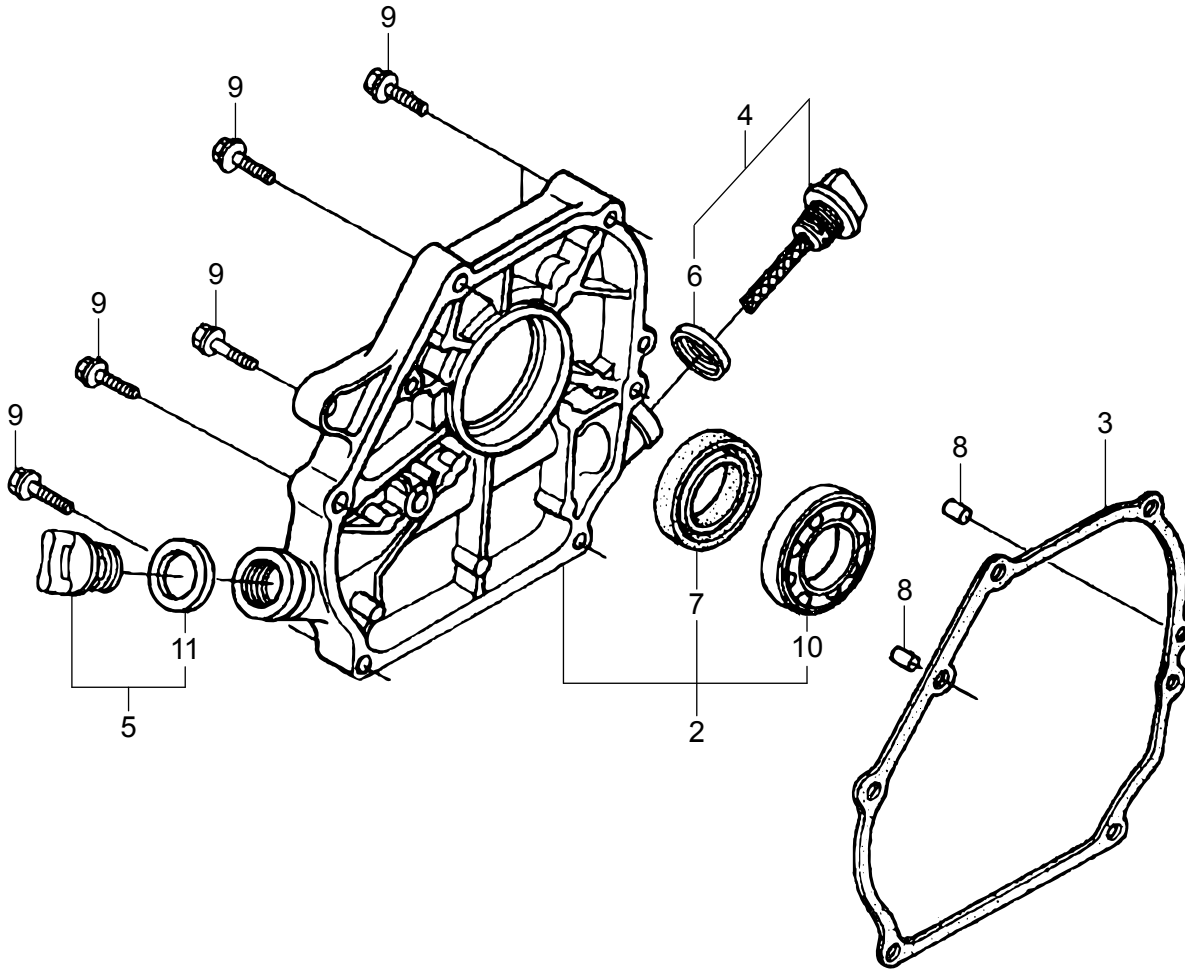

HONDA GX160UT2 SERIES ENG. — CRANKCASE COVER ASSY.

<u>NO.</u>	<u>PART NO.</u>	<u>PART NAME</u>	<u>QTY.</u>	<u>REMARKS</u>
2	11300Z4M640	COVER, ASSY., CRANKCASE.....	1.....	INCLUDES ITEMS W/#
3	11381ZH8801	GASKET, CRANKCASE	1	
4	15600Z0T810	CAP ASSY., OIL FILLER	1.....	INCLUDES ITEMS W/\$
5	15600Z0T820	CAP ASSY., OIL FILLER	1.....	INCLUDES ITEMS W/%
6\$	15625Z0T800	PACKING, OIL FILLER CAP	1	
7#	91201Z0T801	OIL SEAL 25X41X6	1	
8	9430108140	KNOCK PIN 8X14	2	
9	957010803200	FLANGE BOLT 8X32	6	
10#	961006205010	BALL BEARING 6205.....	1.....	REPLACES P/N 961006205000
11%	15625Z0T800	PACKING, OIL FILLER CAP	1	

HONDA GX160UT2 SERIES ENG. — CRANKSHAFT ASSY.

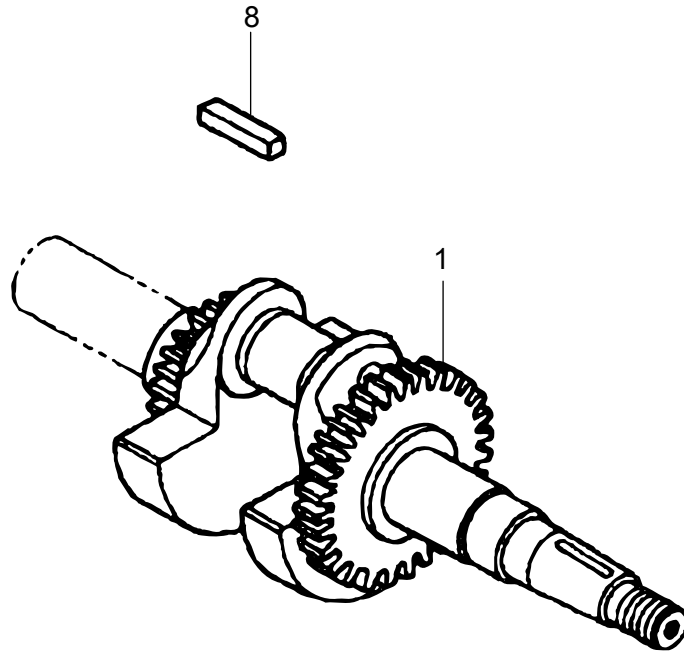

HONDA GX160UT2 SERIES ENG. — CRANKSHAFT ASSY.

<u>NO.</u>	<u>PART NO.</u>	<u>PART NAME</u>	<u>QTY.</u>	<u>REMARKS</u>
1	13310Z4M800	CRANK SHAFT COMPLETE	1	
8	90745ZE1600	KEY 4.78X4.78X38	1	

HONDA GX160UT2 SERIES ENGINE — PISTON ASSY.

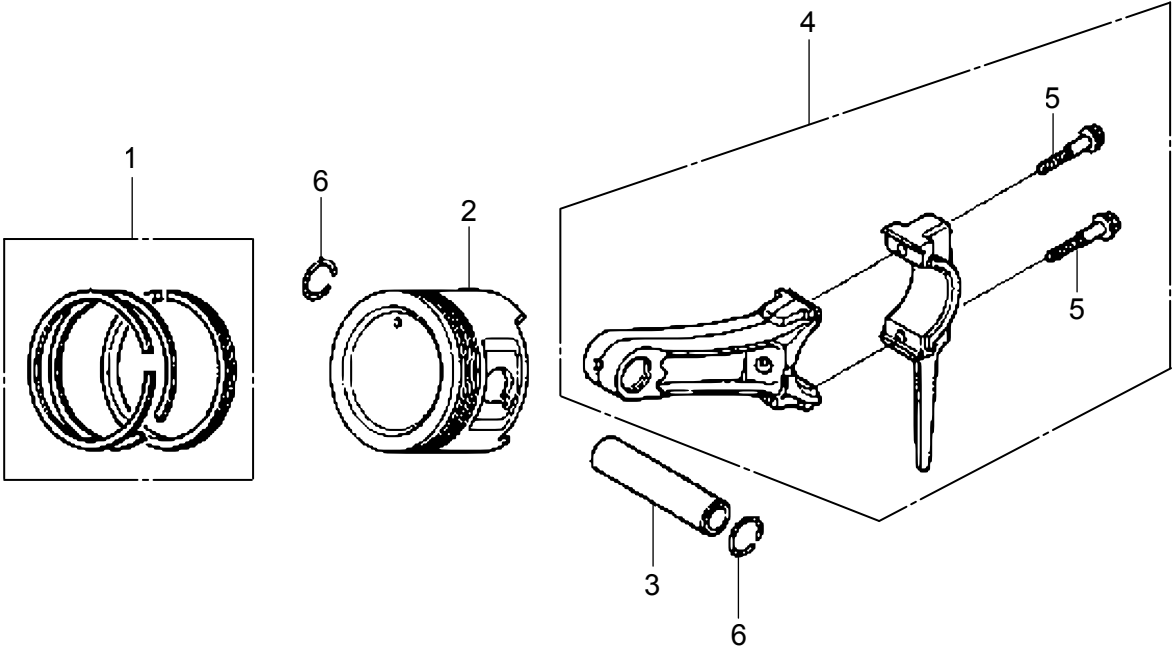

HONDA GX160UT2 SERIES ENGINE — PISTON ASSY.

NO.	PART NO.	PART NAME	QTY.	REMARKS
1	13010Z4M801	RING SET, PISTON (STD)	1	
1◇	13011Z4M003	RING SET, PISTON 0.25	1	
1◇	13012Z4M003	RING SET, PISTON 0.50	1	
2	13101Z4M800	PISTON (STD)	1	
2◇	13102Z4M800	PISTON 0.25	1	
2◇	13103Z4M800	PISTON 0.50	1	
3	13111Z4M000	PIN, PISTON	1	
4◆	13200Z4M000	ROD ASSY., CONNECTING.....	1	INCLUDES ITEM W\$
4◇	13200Z0T900	ROD ASSY., CONNECTING.....	1	INCLUDES ITEM W\$
5\$	90001Z4M000	BOLT, CONNECTING ROD 6X34.5	2	
6	90551ZE1000	CLIP, PISTON PIN 18MM	2	

NOTICE

- ◆ GX160UT2QMX2
- ◇ GX160UT2QMXC
- ▷ GX160UT2QCM

HONDA GX160UT2 SERIES ENG. — CAMSHAFT ASSY.

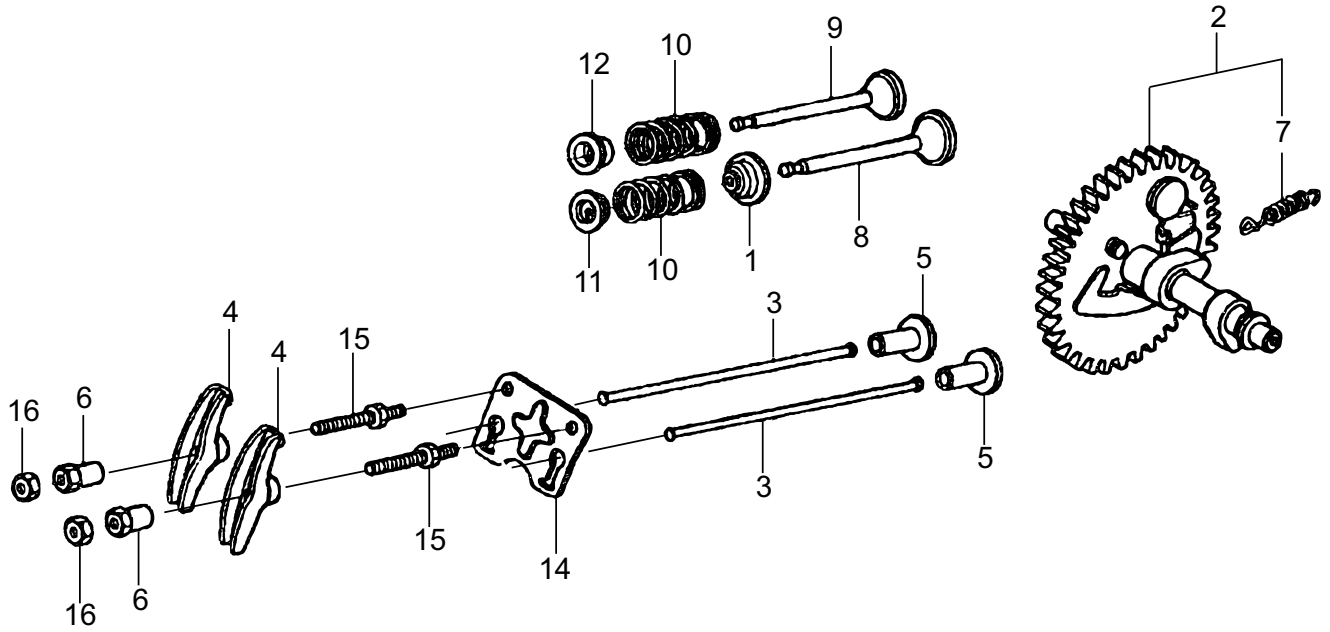

HONDA GX160UT2 SERIES ENG. — CAMSHAFT ASSY.

NO.	PART NO.	PART NAME	QTY.	REMARKS
1	12209Z4M801	SEAL, VALVE STEM	1	
2	14100Z4M000	CAMSHAFT ASSY.....	1	INCLUDES ITEM W/\$
3◆◇	14110Z4M000	ROD, COMPLETE, PUSH	2	
3●	14410Z4M000	ROD COMPLETE, PUSH	2	
4	14431ZE1000	ARM, VALVE ROCKER	2	
5	14441ZE1010	VALVE LIFTER	2	
6◆	14451ZE1013	PIVOT, ROCKER ARM	2	
6◇●	14451Z4M000	PIVOT, ROCKER ARM	2	
7\$	14568ZE1000	SPRING, WEIGHT RETURN	1	
8	14711Z4M000	VALVE, INTAKE	1	
9	14721Z4M000	VALVE, EXHAUST	1	
10	14751ZF1000	SPRING, VALVE	2	
11◆	14771ZE1000	RETAINER, INTAKE VALVE	1	
11◇●	14771Z0T900	RETAINER, INTAKE VALVE	1	
12◆	14773ZE1000	RETAINER, EXHAUST VALVE	1	
12◇●	14771Z0T900	RETAINER, EXHAUST VALVE	1	
14	14791Z4M000	PLATE, PUSH ROD GUIDE	1	
15	90012ZE0010	BOLT, PIVOT, 8MM	2	
16	90206ZE1000	NUT, PIVOT ADJUSTING	2	

NOTICE

- ◆ GX160UT2QMX2
- ◇ GX160UT2QMXC
- GX160UT2QCM

HONDA GX160UT2 SERIES ENG. — RECOIL STARTER ASSY.

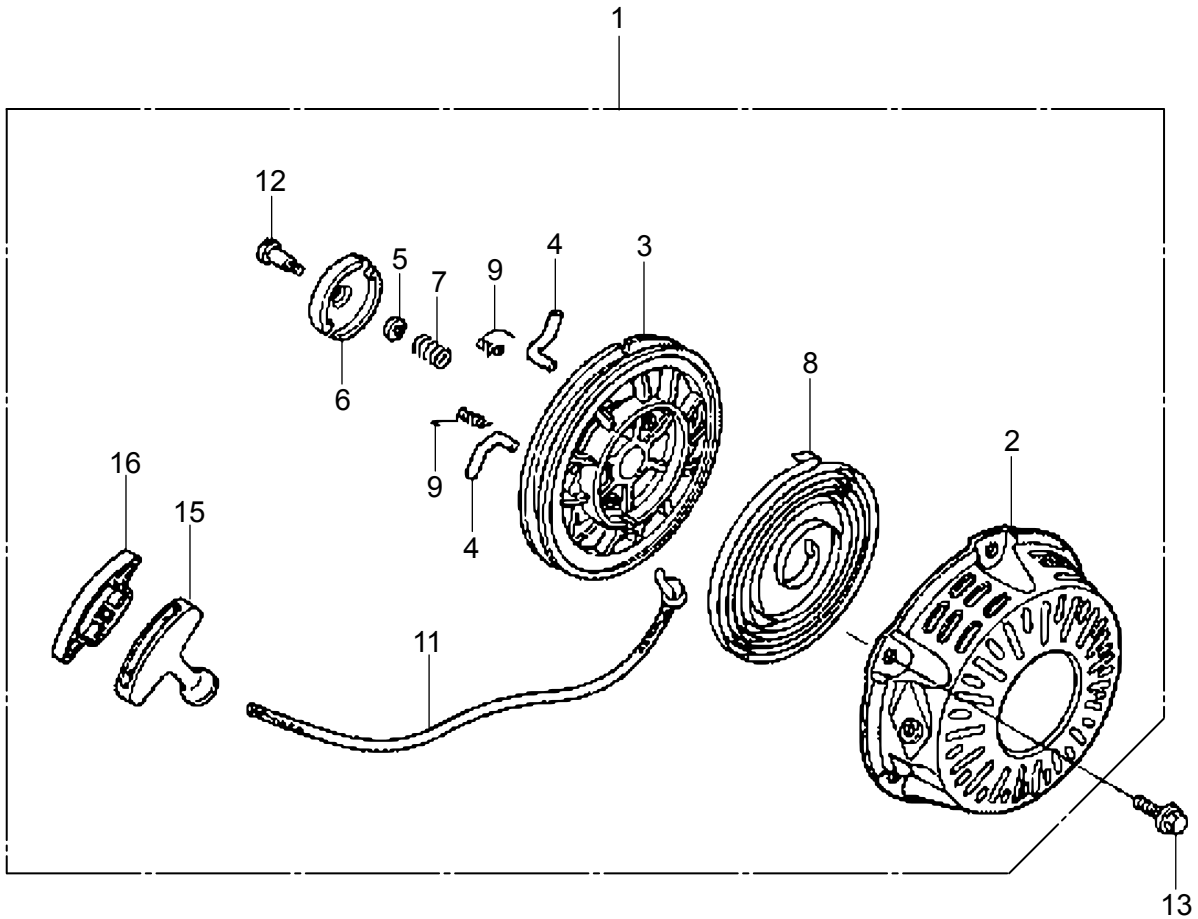

HONDA GX160UT2 SERIES ENG. — RECOIL STARTER ASSY.

NO.	PART NO.	PART NAME	QTY.	REMARKS
1◆◇	28400Z4M305ZD	STARTER ASSY., RECOIL	1.....	INCLUDES ITEMS W/\$
1▷	28400Z4M306ZC	STARTER ASSY., RECOIL	1.....	INCLUDES ITEMS W/\$
2\$	28410Z4M003ZD	CASE COMPLETE, RECOIL STARTER	1	
3\$◆◇	28421Z0T003	REEL, RECOIL STARTER	1	
3\$▷	28421Z1T702	REEL, RECOIL STARTER	1	
4\$◆◇	28422ZH8801	RATCHET, STARTER	2	
4\$▷	28422Z1T701	RATCHET, STARTER	2	
5\$	28431ZH8801	PLATE, FRICTION	1	
6\$◆◇	28433ZH8801	RATCHET GUIDE	1	
6\$▷	28433Z1T702	RATCHET GUIDE	1	
7\$	28441ZH8801	FRICTION SPRING	1	
8\$	28442ZH8003	SPRING, RECOIL STARTER	1	
9\$◆◇	28443ZH8801	SPRING, RETURN	2	
9\$▷	28443Z1T701	SPRING, RETURN	2	
11\$	28462ZH8003	ROPE, RECOIL STARTER	1	
12\$	90003ZH8801	SET SCREW	1	
13◆	90008ZE2003	BOLT, FLANGE 6X10	3	
13▷	957010600800	BOLT, FLANGE 6X8	3	
15\$	28461Z4M305	KNOB, RECOIL STARTER	1	
16\$	28463Z4M003	KNOB, REINFORCEMENT	1	

NOTICE

- ◆ GX160UT2QMX2
- ◇ GX160UT2QMXC
- ▷ GX160UT2QCM

HONDA GX160UT2 SERIES ENG. — FAN COVER ASSY.

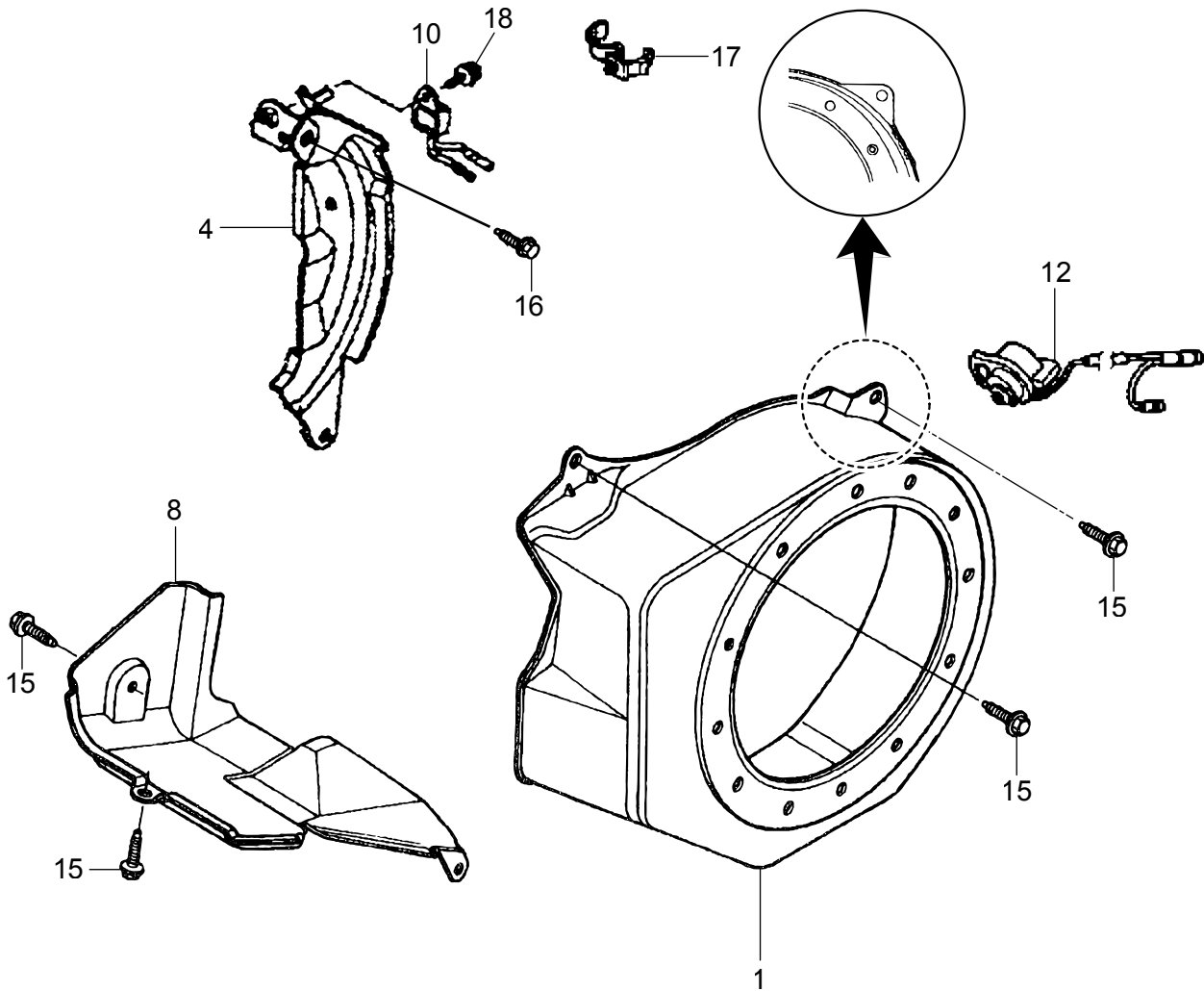

HONDA GX160UT2 SERIES ENG. — FAN COVER ASSY.

<u>NO.</u>	<u>PART NO.</u>	<u>PART NAME</u>	<u>QTY.</u>	<u>REMARKS</u>
1	19610Z4M000ZB	COVER COMPLETE, FAN	1	
4	19611Z4M810	PLATE COMPLETE, SIDE (OIL ALERT)	1	
8◆◇	19630Z4M000	SHROUD COMPLETE	1	
8●	19630Z4M010	SHROUD COMPLETE	1	
10◆	34150ZH7013	ALERT UNIT, OIL	1	
10◇●	34150ZH7023	ALERT UNIT, OIL	1	
12◆◇	35120Z0T851	SWITCH ASSY., E/G STOP	1	
12●	35120Z0T831	SWITCH ASSY., E/G STOP	1	
15	90013883000	FLANGE BOLT 6X12	6	
16	90022888010	FLANGE BOLT 6X20	1	
17	90601ZH7013	CLIP, HARNESS	1	
18	957010600800	FLANGE BOLT 6X8	1	

NOTICE

- ◆ GX160UT2QMX2
- ◇ GX160UT2QMXC
- GX160UT2QCM

HONDA GX160UT2 SERIES ENG. — CARBURETOR ASSY.

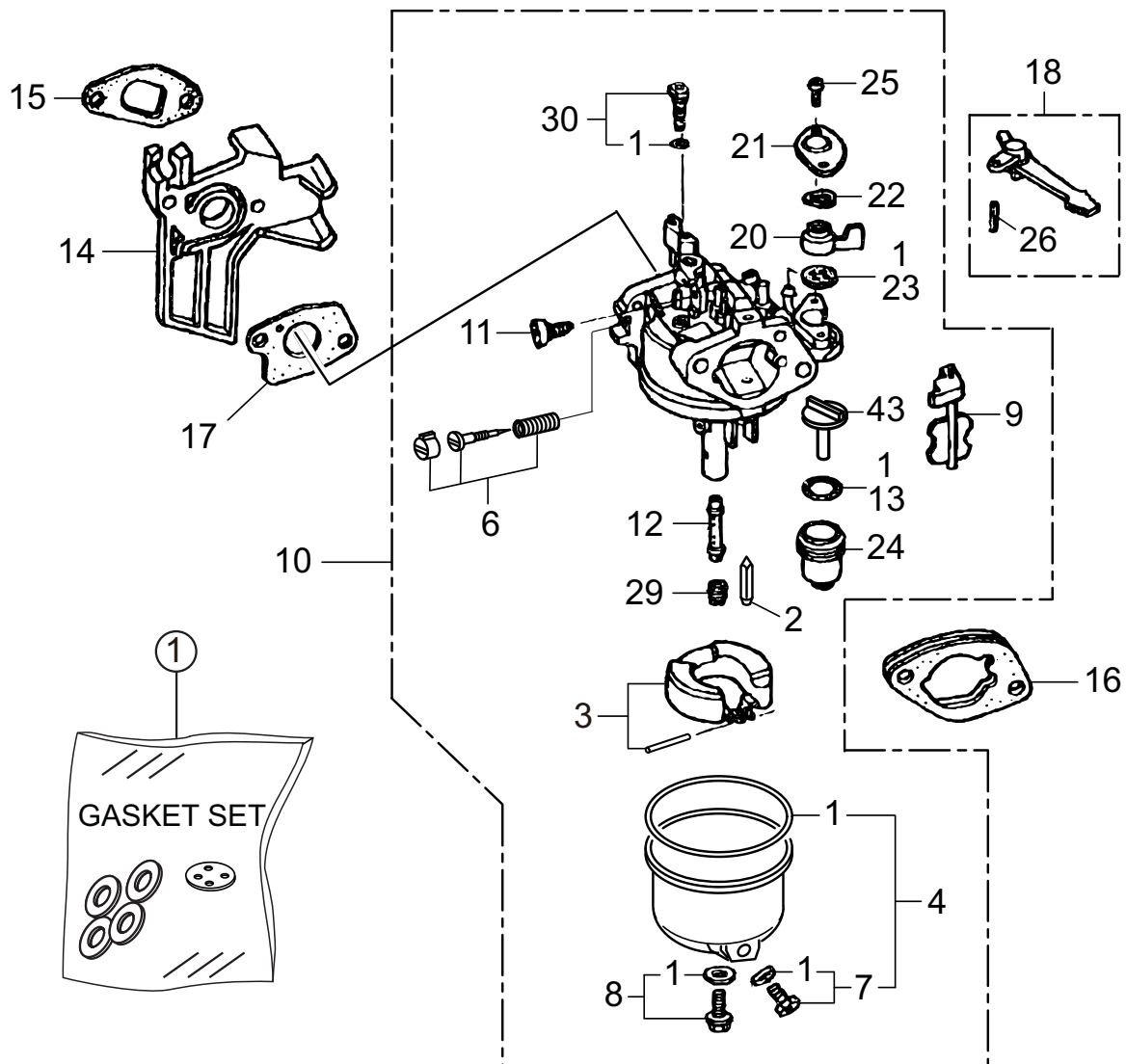

NOTICE

Gasket set, item 1 included with items 4, 7, 8, 13, 23 and 30.

HONDA GX160UT2 SERIES ENG. — CARBURETOR ASSY.

NO.	PART NO.	PART NAME	QTY.	REMARKS
1#♣*%	16010ZE1812	GASKET SET	1	
2#♣*	16011ZE0005	FLOAT VALVE SET	1	
3#♣*	16013Z0SB01	FLOAT SET	1	
4#♣*	16015Z4M911	CHAMBER SET, FLOAT	1	INCLUDES ITEM W/%, &
6#♣*	16016ZH7W01	SCREW SET, PILOT	1	
7#♣*&	16024Z5T901	SCREW SET, DRAIN	1	INCLUDES ITEM W/%
8#♣*	16028Z5T901	SCREW SET	1	INCLUDES ITEM W/%
9#♣*	16044Z4M911	CHOKE SET	1	
10♦	16100Z4M911	CARBURETOR ASSY., (QMX2).....	1	INCLUDES ITEMS W/#
10◇	16100Z4MV22	CARBURETOR ASSY., (QMXC)	1	INCLUDES ITEMS W/♣
10▷	16100Z4M781	CARBURETOR ASSY., (QCM).....	1	INCLUDES ITEMS W/*
11#♣*	16124ZE0005	SCREW, THROTTLE STOP	1	
12#♦	16166Z4M911	NOZZLE, MAIN	1	
12♣◇	16166Z4MV21	NOZZLE, MAIN	1	
12*▷	16166Z4M781	NOZZLE, MAIN	1	
13#♣*	16955283000	PACKING, CUP	1	INCLUDES ITEM W/%
				REPLACES P/N 16173001004
14	16211Z4M000	INSULATOR, CARBURETOR	1	
15	16212ZH8800	PACKING, INSULATOR	1	
16	16220ZE1020	SPACER COMPLETE, CARBURETOR	1	
17	16221ZH8801	PACKING, CARBURETOR	1	
18	16610ZE1000	CHOKE LEVER COMPLETE	1	INCLUDES ITEM W/\$
20#♣*	16953ZE1812	LEVER, COCK	1	
21#♣*	16954ZE1812	PLATE, LEVER SETTING	1	
22#♣*	16956ZE1811	SPRING, COCK LEVER	1	
23#♣*	16957ZE1812	PACKING, FUEL COCK	1	INCLUDES ITEM W/%
24#♣*	16967ZE0811	CUP, FUEL STRAINER	1	
25#♣*	93500030060H	SCREW 3X6	2	
26\$	9430520122	SPRING PIN 2X12	1	
29#♣♦◇	99101ZH80700	MAIN JET #70	1	
29*▷	99101ZH80720	MAIN JET #72	1	
30#♦	99204ZE00350	PILOT, JET SET #35	1	INCLUDES ITEM W/%
30♣◇	99204ZE00380	PILOT, JET SET #38	1	INCLUDES ITEM W/%
30*▷	99204ZE20400	PILOT, JET SET #40	1	INCLUDES ITEM W/%
43#♣*	16959Z5T901	FILTER, CUP	1	

NOTICE

- ◆ GX160UT2QMX2
- ◇ GX160UT2QMXC
- ▷ GX160UT2QCM

HONDA GX160UT2QMX2 — AIR CLEANER ASSY.

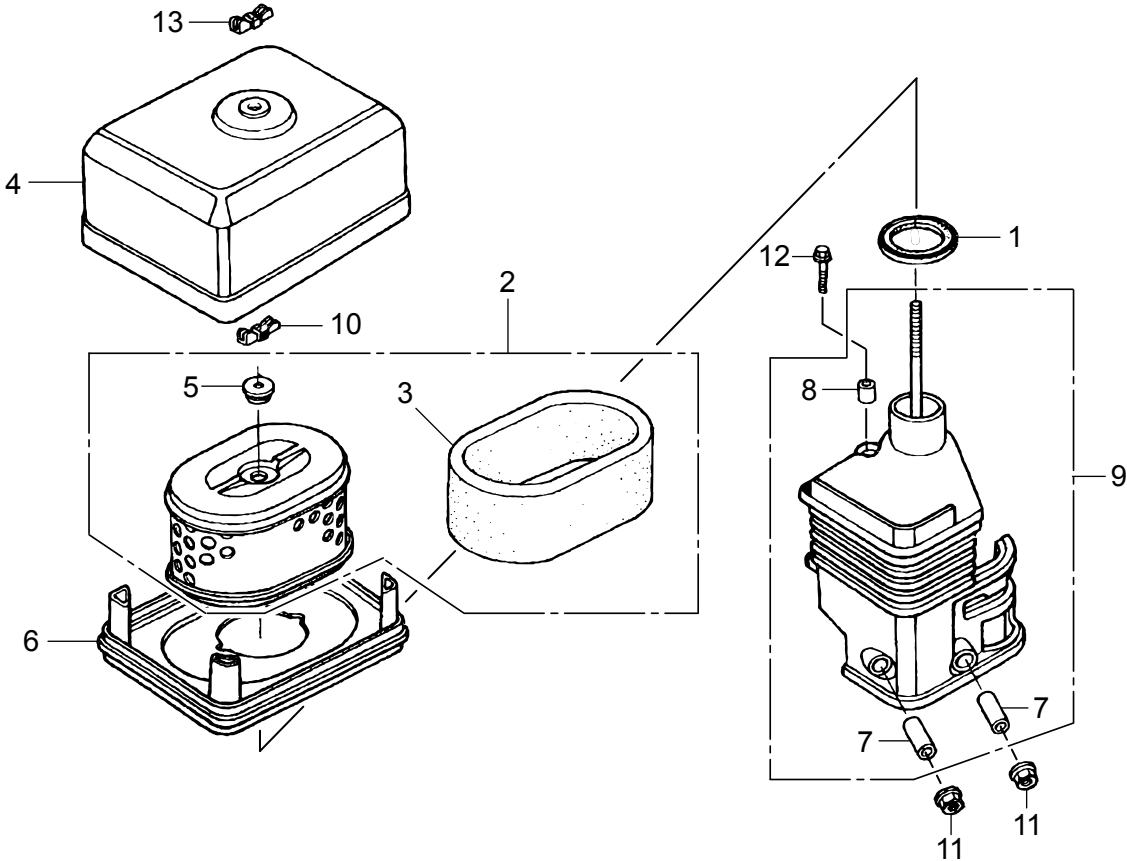

HONDA GX160UT2QMX2 — AIR CLEANER ASSY.

<u>NO.</u>	<u>PART NO.</u>	<u>PART NAME</u>	<u>QTY.</u>	<u>REMARKS</u>
1	16271ZE1000	PACKING, ELBOW	1	
2	17210ZE1517	ELEMENT, AIR CLEANER	1.....	INCLUDES ITEMS W/#
3#	17218ZE1507	OUTER ELEMENT	1	
4	17231Z4M010	COVER, AIR CLEANER	1	
5#	17232891000	GROMMET, AIR CLEANER	1	
6	17235Z4M830	NOSE, SILENCER	1	
7%	17238ZE7010	COLLAR, AIR CLEANER	2	
8%	17239ZE1000	COLLAR (B), AIR CLEANER	1	
9	17410Z4M000	ELBOW COMPLETE, AIR CLEANER	1.....	INCLUDES ITEMS W/%
10	90325044000	NUT, TOOL BOX SETTING	1	
11	9405006000	FLANGE NUT 6MM	2	
12	957010602000	FLANGE BOLT 6X20	1	
13	90300Z1V000	NUT, AIR CLEANER	1	

HONDA GX160UT2QMXC ENGINE — AIR CLEANER ASSY.

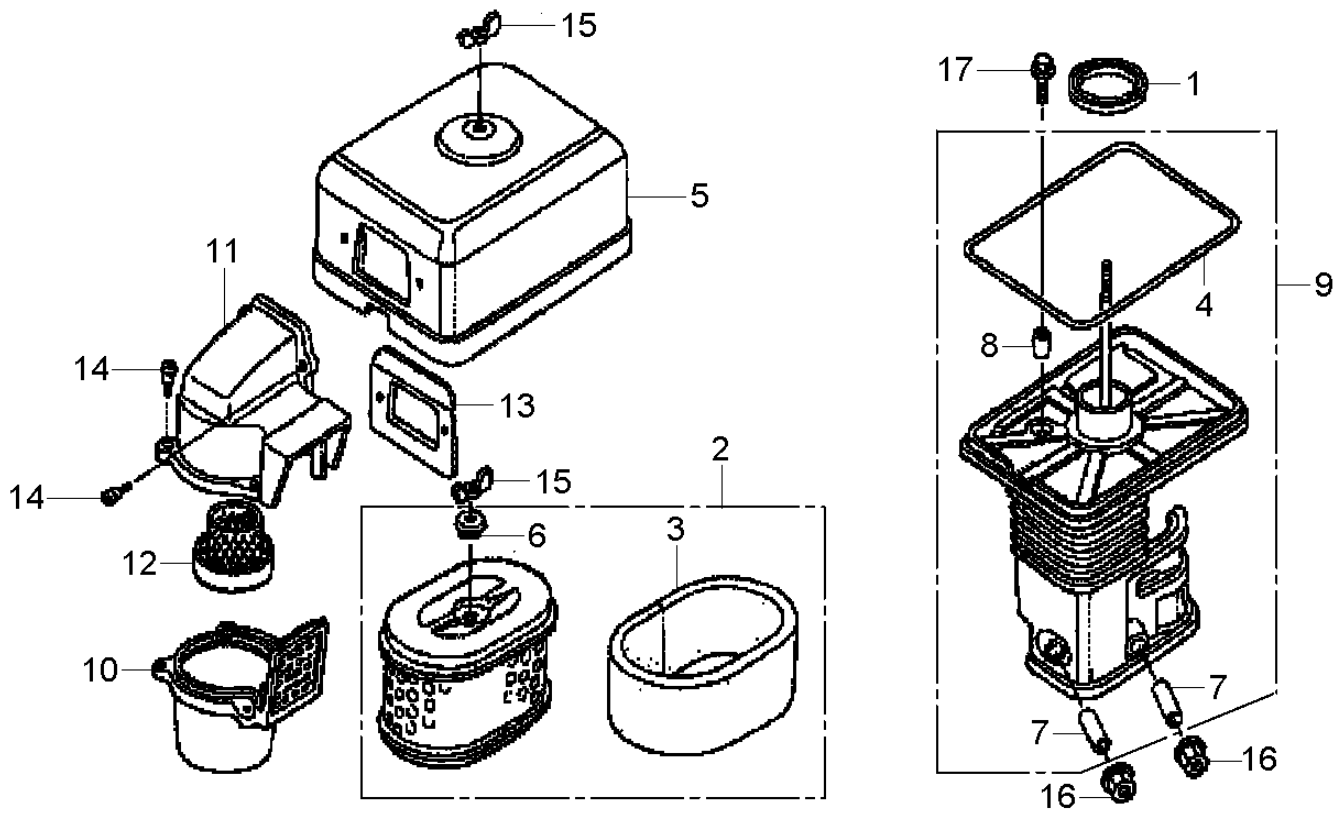

HONDA GX160UT2QMXC ENGINE — AIR CLEANER ASSY.

<u>NO.</u>	<u>PART NO.</u>	<u>PART NAME</u>	<u>QTY.</u>	<u>REMARKS</u>
1	16271ZE1000	PACKING, ELBOW	1	
2	17210ZE1517	ELEMENT, AIR CLEANER	1.....	INCLUDES ITEMS W/\$
3\$	17218ZE1507	FILTER, OUTER ELEMENT	1	
4%	17219733010	PACKING, AIR CLEANER COVER	1	
5	17230ZE1841	COVER, AIR CLEANER	1	
6\$	17232891000	GROMMET, AIR CLEANER	1	
7%	17238ZE7010	COLLAR, AIR CLEANER	2	
8%	17239733000	COLLAR B, AIR CLEANER	1	
9	17410ZE1840	ELBOW COMPLETE, AIR CLEANER	1.....	INCLUDES ITEMS W/%
10	17470ZE1842	CASE, PRE AIR CLEANER	1	
11	17475ZE1841	CAP, PRE AIR CLEANER	1	
12	17476ZE1841	GUIDE, PRE AIR CLEANER	1	
13	17478ZE1841	PLATE, PRE AIR CLEANER	1	
14	90300GB0900	BOLT, MUD GUARD	5	
15	90325044000	NUT, TOOL BOX SETTING	2	
16	9405006000	NUT, FLANGE, 6MM	2	
17	957010602000	BOLT, FLANGE, 6X20	1	

HONDA GX160UT2QCM ENGINE — AIR CLEANER ASSY.

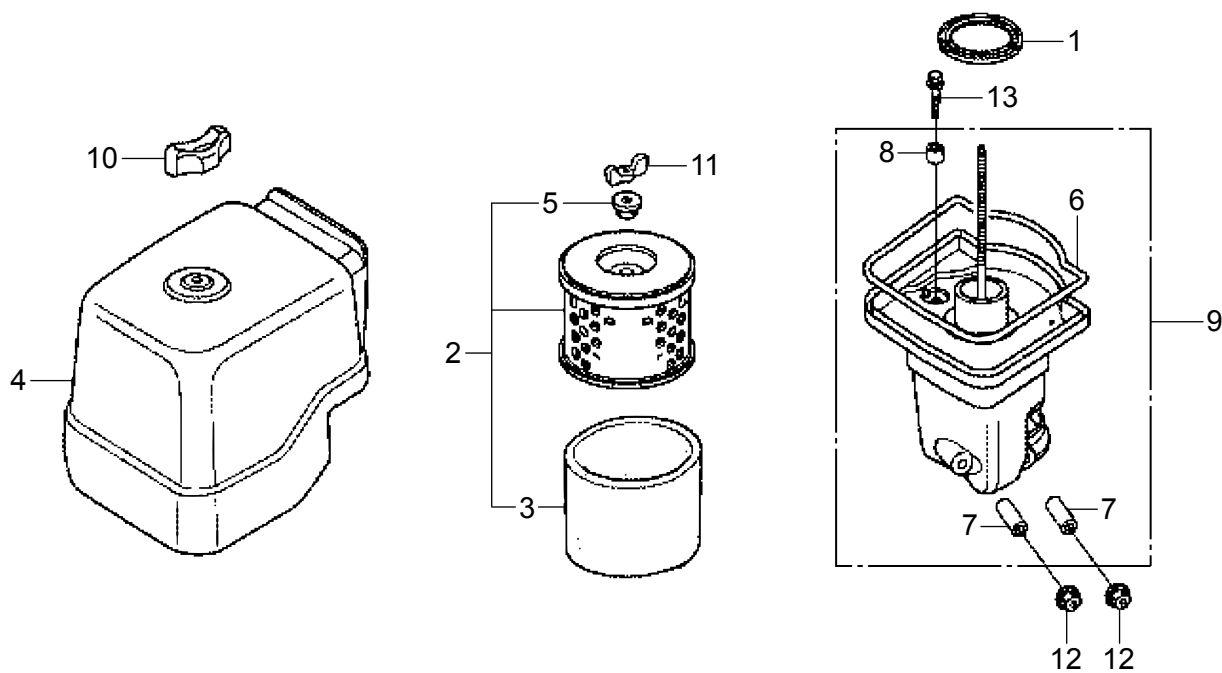

HONDA GX160UT2QCM ENGINE — AIR CLEANER ASSY.

<u>NO.</u>	<u>PART NO.</u>	<u>PART NAME</u>	<u>QTY.</u>	<u>REMARKS</u>
1	16271ZE1000	PACKING, ELBOW	1	
2	17210Z0V781	ELEMENT, AIR CLEANER	1	
3	17218Z0V780	FILTER, OUTER	1	
4	17230Z0V780	COVER ASSY., AIR CLEANER	1	
5	17232891000	GROMMET, AIR CLEANER	1	
6	17233Z0V780	SEAL, AIR CLEANER COVER	1	
7	17238ZE7010	COLLAR, AIR CLEANER	2	
8	17239ZE3840	COLLAR B, AIR CLEANER	1	
9	17410Z0V780	ELBOW COMPLETE, AIR CLEANER	1	
10	90300Z4M800	NUT, AIR CLEANER	1	
11	90325044000	NUT, TOOL BOX SETTING	1	
12	9405006000	FLANGE NUT 6MM	2	
13	957010602000	FLANGE BOLT 6X20	1	

HONDA GX160UT2 SERIES ENGINE — MUFFLER ASSY.

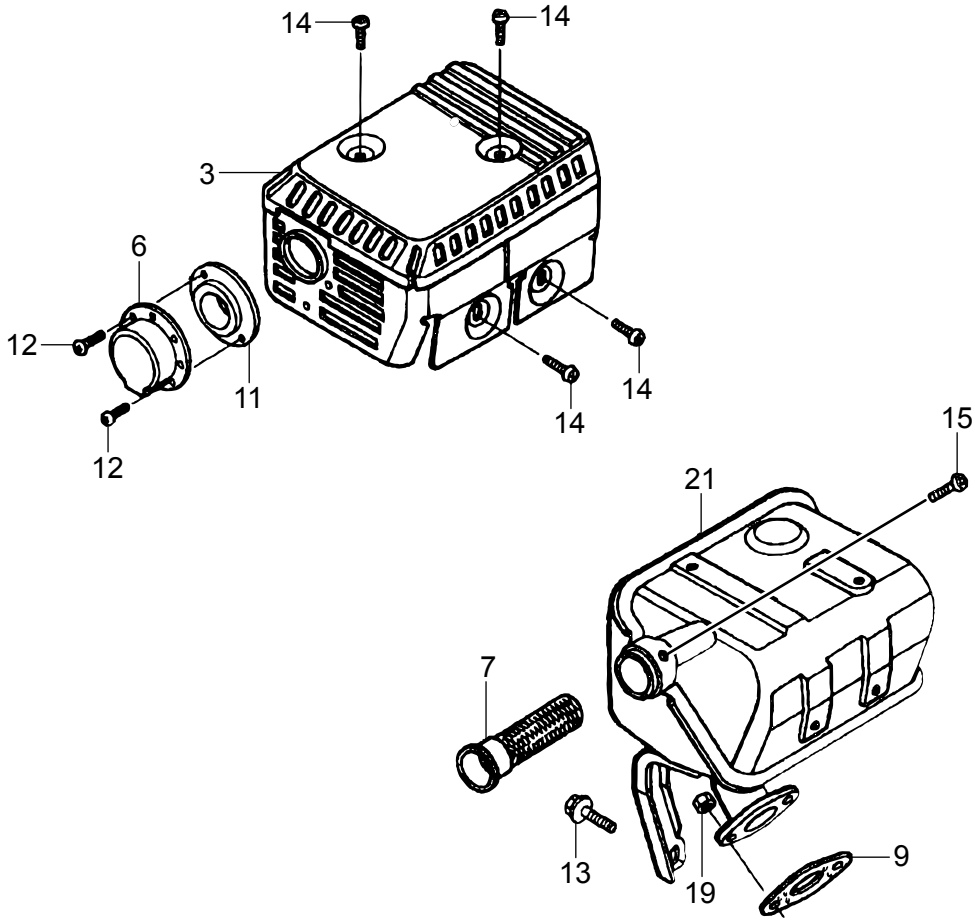

HONDA GX160UT2 SERIES ENGINE — MUFFLER ASSY.

<u>NO.</u>	<u>PART NO.</u>	<u>PART NAME</u>	<u>QTY.</u>	<u>REMARKS</u>
3	18320Z4M000	PROTECTOR COMPL., MUFFLER (STD)	1	
6	18340ZE1010	DEFLECTOR COMPLETE	1	
7	18355ZE1000	ARRESTER, SPARK	1	
9	18381Z0T801	GASKET, MUFFLER	1	
11	18522ZE1000	GUIDE, MUFFLER	1	
12	90002Z0T800	SCREW, TAPPING, 4X8	2	
13	90016ZE1000	FLANGE BOLT 6X13	1	
14	90050ZE1000	SCREW, TAPPING, 5X8	4	
15	90055ZE1000	SCREW, TAPPING, 4X6	1	
19	94001080000S	NUT 8MM	2	
21	18310Z4MV51	MUFFLER COMPLETE	1	

HONDA GX160UT2 SERIES ENGINE — FUEL TANK ASSY.

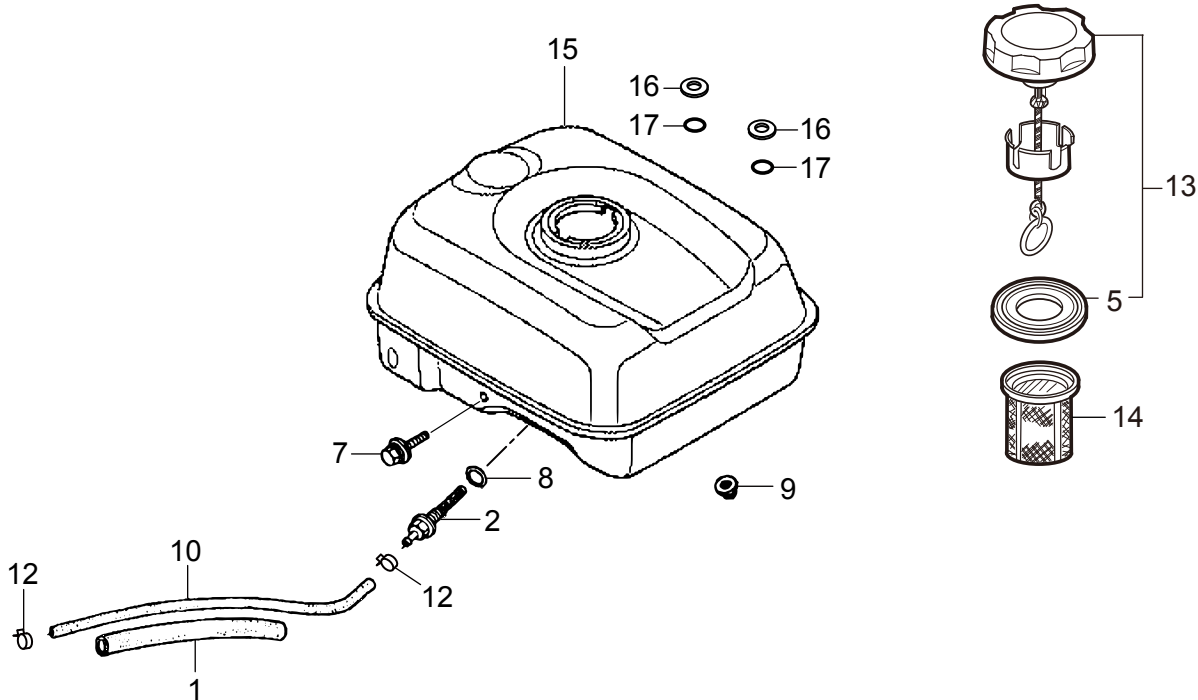

HONDA GX160UT2 SERIES ENGINE — FUEL TANK ASSY.

NO.	PART NO.	PART NAME	QTY.	REMARKS
1	16854ZH8000	RUBBER, SUPPORT (107MM)	1	
2	16955ZE1010	JOINT, FUEL TANK	1	
5%	17631Z0T801	PACKING, FUEL FILLER CAP	1	
7	90004ZH7003	FLANGE BOLT, 6X29	1	
8	91353671003	O-RING, 14MM.....	1.....	REPLACES P/N 91353671004
9	9405006000	FLANGE NUT, 6MM	2	
10	91424Z4M003	TUBE, FUEL 4.5X145	1	
12	950024080008	CLAMP, TUBE (D8)	2	
13◆	17620Z4H030	CAP COMPLETE, FUEL TANK.....	1.....	INCLUDES ITEM W/% REPLACES P/N 17620Z4H020
13◇▶	17620Z4H900	CAP COMPLETE, FUEL TANK.....	1.....	INCLUDES ITEM W/%
14	17672Z4H000	FUEL FILTER, FUEL TANK	1	
15	17510Z4M000ZB	FUEL TANK COMPLETE, NH1, BLK	1	
16	90503898000	WASHER, TANK CUSHION	2	
17	91302Z4M003	O-RING 5.5X1.5	2	

NOTICE

- ◆ GX160UT2QMX2
- ◇ GX160UT2QMXC
- ▶ GX160UT2QCM

HONDA GX160UT2 SERIES ENGINE — FLYWHEEL ASSY.

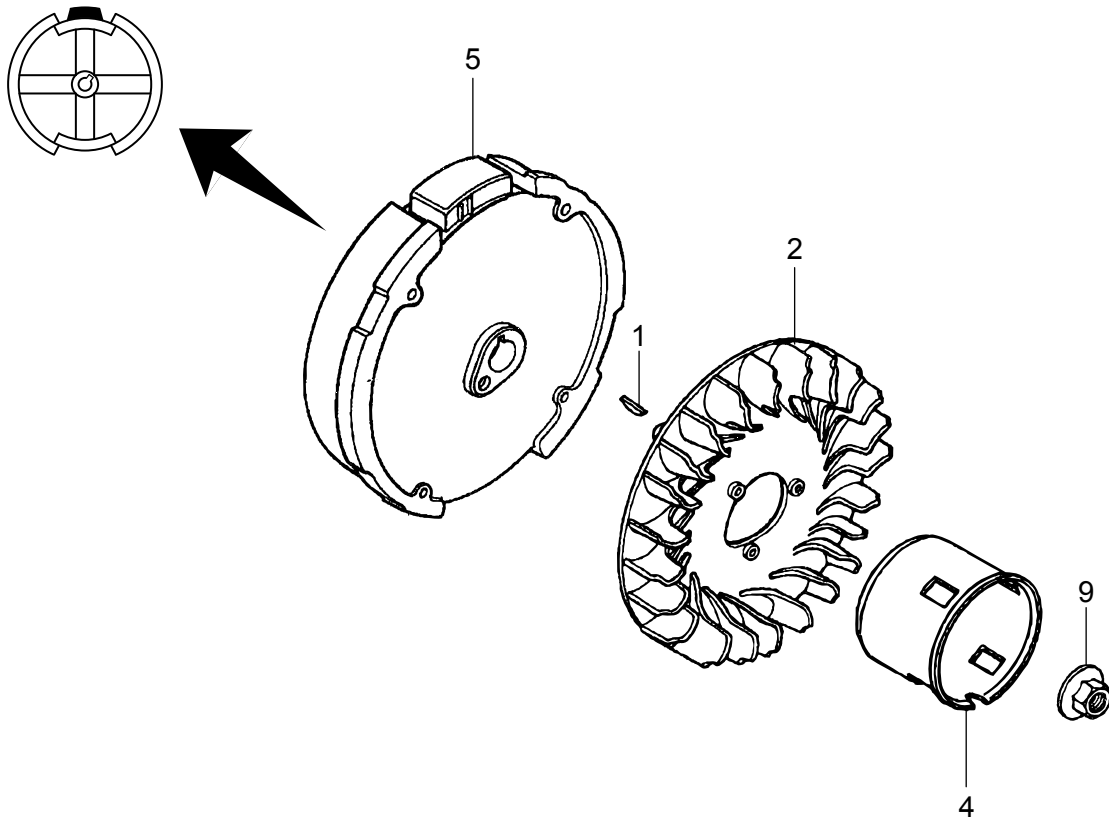

HONDA GX160UT2 SERIES ENGINE — FLYWHEEL ASSY.

<u>NO.</u>	<u>PART NO.</u>	<u>PART NAME</u>	<u>QTY.</u>	<u>REMARKS</u>
1	13331357000	WOODRUFF KEY 25X18	1	
2	19511ZE1000	COOLING FAN	1	
4◆◇	28451ZH8801	STARTER, PULLEY	1	
4●	28451Z4M003	STARTER, PULLEY	1	
5	31110Z4M000	FLYWHEEL COMPLETE	1	
9	90201Z0T800	NUT, SPECIAL 14MM	1	

NOTICE

- ◆ GX160UT2QMX2
- ◇ GX160UT2QMXC
- GX160UT2QCM

HONDA GX160UT2QMX2/QMXC ENGINE — IGN. COIL ASSY.

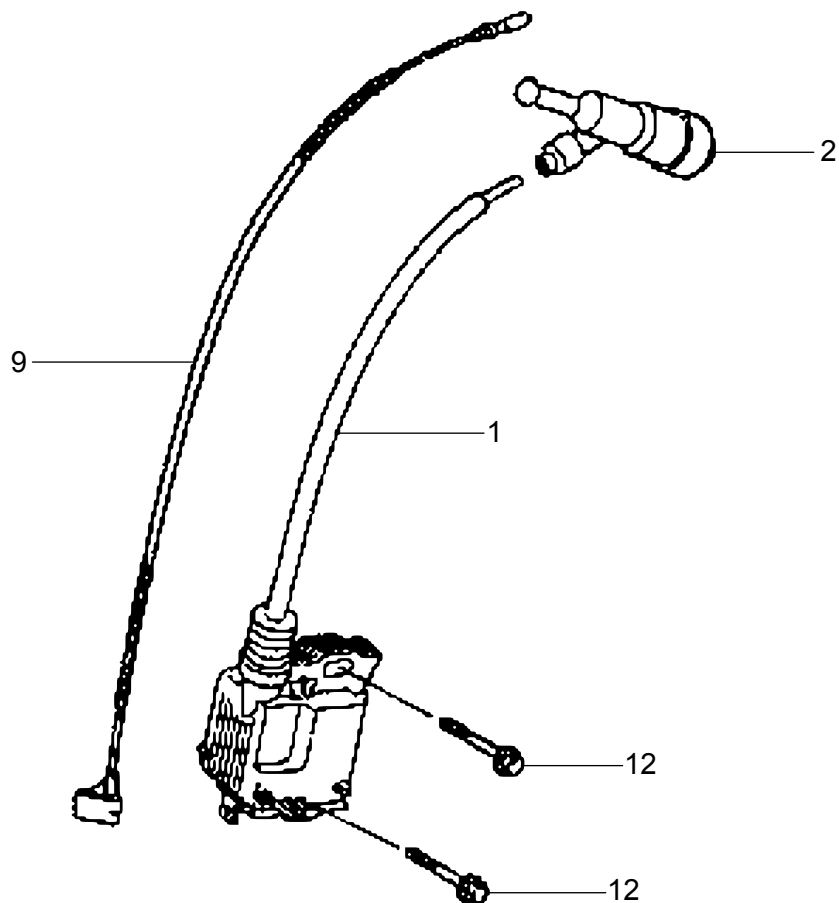

HONDA GX160UT2QMX2/QMXC ENGINE — IGN. COIL ASSY.

NO.	PART NO.	PART NAME	QTY.	REMARKS
1◆◆	30500Z0T802	COIL ASSY., IGNITION	1	
2◆	30700Z0T811	CAP ASSY., NOISE SUPPRESSOR	1	
2◇	30700Z0T812	CAP ASSY., NOISE SUPPRESSOR	1	
9	36101ZE1010	CORD, STOP SWITCH 370MM	1	
12	957010602500	FLANGE BOLT 6X25	2.....	REPLACES P/N 90121952000

NOTICE
◆ GX160UT2QMX2
◇ GX160UT2QMXC

HONDA GX160UT2QCM ENGINE — IGN. COIL ASSY.

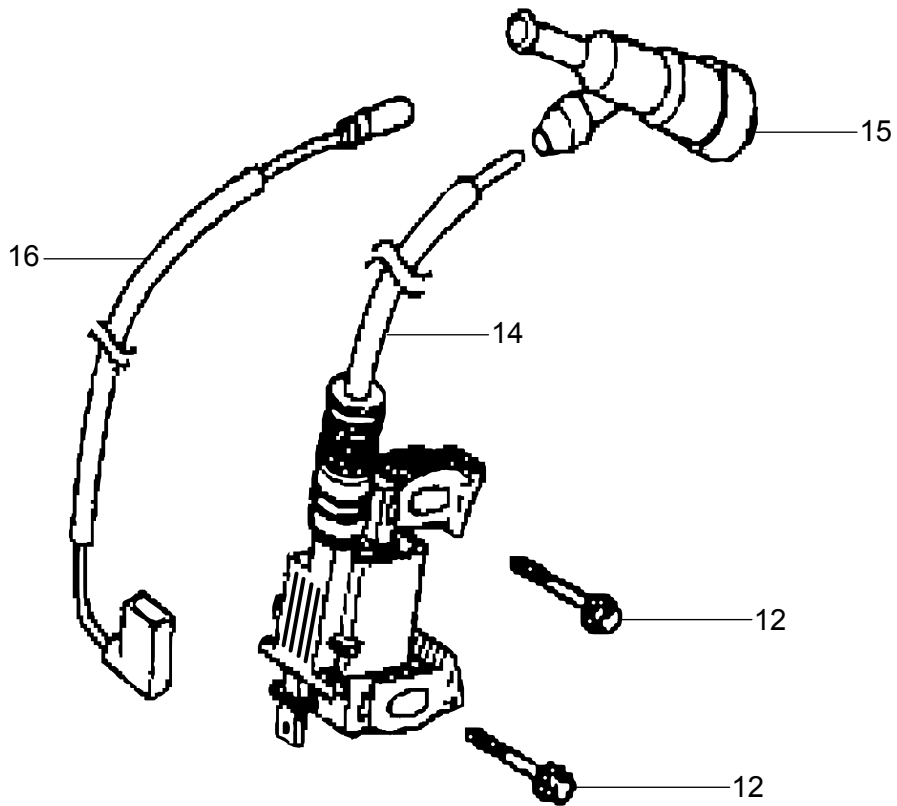

HONDA GX160UT2QCM ENGINE — IGN. COIL ASSY.

<u>NO.</u>	<u>PART NO.</u>	<u>PART NAME</u>	<u>QTY.</u>	<u>REMARKS</u>
12	957010602500	FLANGE BOLT 6X25	2.....	REPLACES P/N 90121952000
14	30500Z0T003	COIL ASSY., IGNITION	1	
15	30700Z0T821	CAP ASSY., NOISE SUPPRESSOR	1	
16	32195Z0T003	CORD, STOP SWITCH 370MM	1	

HONDA GX160UT2 SERIES ENGINE — CONTROL ASSY.

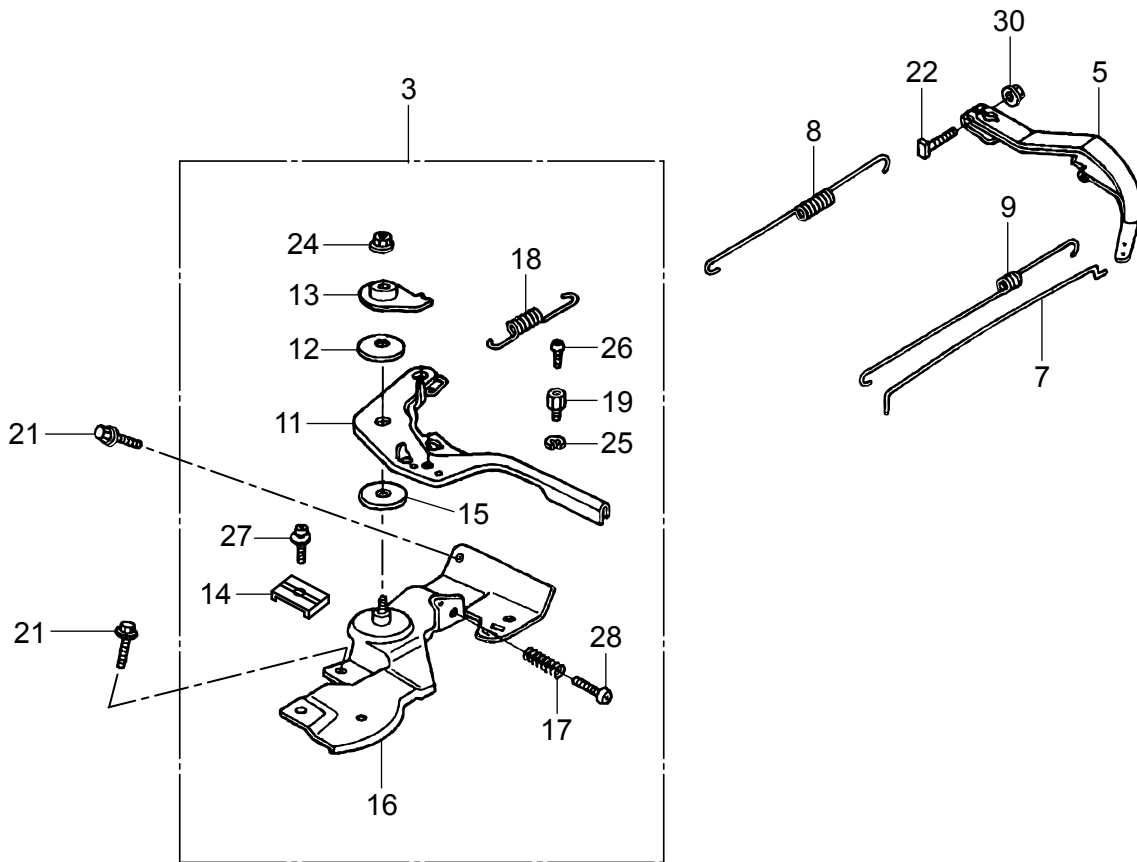

HONDA GX160UT2 SERIES ENGINE — CONTROL ASSY.

NO.	PART NO.	PART NAME	QTY.	REMARKS
3◆◇	16500Z4M306	CONTROL ASSY.....	1.....	INCLUDES ITEMS W/#
3●	16500Z0V306	CONTROL ASSY.....	1.....	INCLUDES ITEMS W/#
5	16551Z4M000	ARM, GOVERNOR	1	
7	16555Z4M000	ROD, GOVERNOR	1	
8	16561Z4M010	SPRING, GOVERNOR	1	
9	16562Z4M000	SPRING, THROTTLE RETURN	1	
11#	16571Z4M000	LEVER, CONTROL	1	
12#	16574ZE1000	LEVER, SPRING	1	
13#	16575ZH8000	WASHER, CONTROL LEVER	1	
14#	16576891000	HOLDER, CABLE	1	
15#	16578ZE1000	SPACER, CONTROL LEVER	1	
16#◆	16580Z4M810	BASE COMPLETE, CONTROL	1	
16#◇	16580Z4M850	BASE COMPLETE, CONTROL	1	
16#●	16580Z0V780	BASE COMPLETE, CONTROL	1	
17#	16584883300	ADJUSTING SPRING	1	
18#	16592ZE1810	SPRING, CABLE, RETURN	1	
19#	16594883010	HOLDER, WIRE	1	
21	90013883000	FLANGE BOLT 6X12	2	
22#◆	90015ZE5010	BOLT, GOVERNOR ARM	1	
22#◇●	90015Z5T000	BOLT, GOVERNOR ARM	1	
24#	90114SA0000	LOCK NUT 6MM	1	
25#	90605230000	CIR CLIP	1	
26#	0043504060	SCREW 4X6	1.....	REPLACES P/N 93500040060H
27#	0202005T125	SCREW 5X16	1.....	REPLACES P/N 93500050160A
28#	93500050250H	SCREW 5X25	1	
30	9405006000	FLANGE NUT 6MM	1	

NOTICE

- ◆ GX160UT2QMX2
- ◇ GX160UT2QMXC
- GX160UT2QCM

HONDA GX160UT2 SERIES ENGINE — DECALS ASSY.

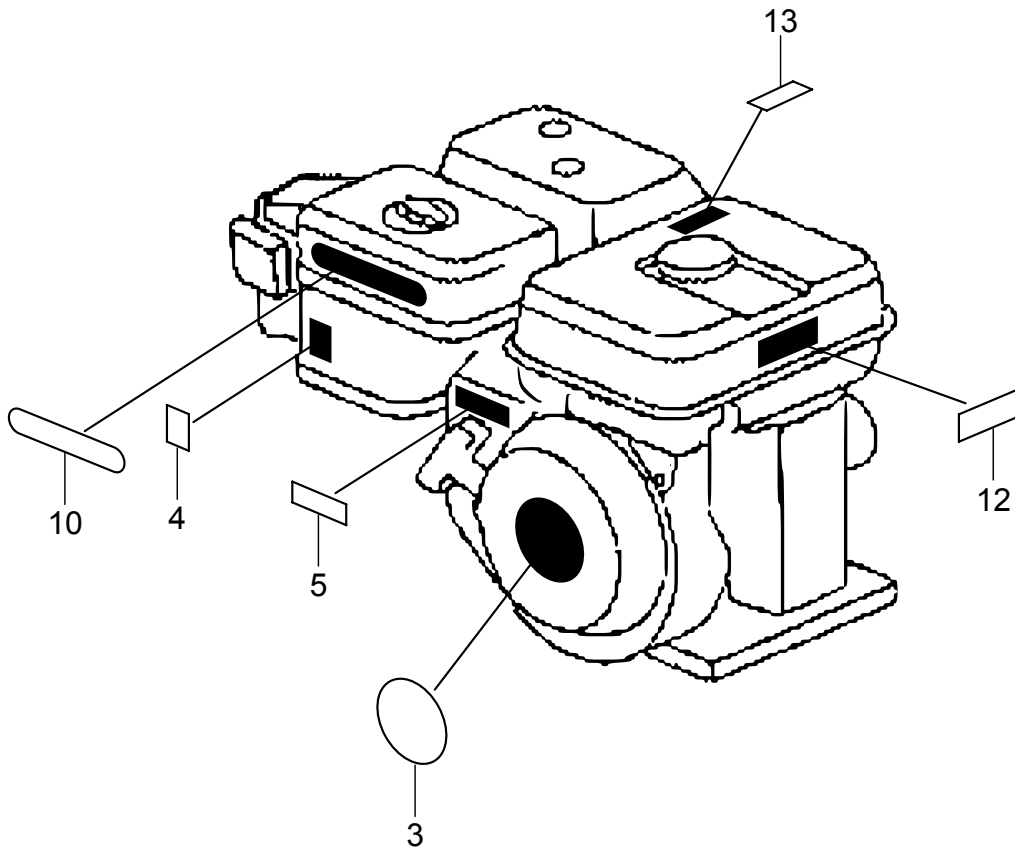

HONDA GX160UT2 SERIES ENGINE — DECALS ASSY.

<u>NO.</u>	<u>PART NO.</u>	<u>PART NAME</u>	<u>QTY.</u>	<u>REMARKS</u>
3	87521Z4M000	EMBLEM (GX160)	1	
4	87528Z4M000	MARK, CHOKE	1	
5	87532ZH7000	MARK, THROTTLE INDICATION	1	
10◇	87535ZE1841	MARK, AIR CLEANER	1	
10●	87602Z0V780	MARK, SALES POINT	1	
12	87516Z4H010	MARK, OP CAUTION	1	
13	87539Z4M000	MARK, EX. CAUTION	1	

NOTICE

- ◆ GX160UT2QMX2
- ◇ GX160UT2QMXC
- ▶ GX160UT2QCM