

**PARTS MANUAL**



*Mikasa* **SERIES**  
**MODEL MTR40HF**  
**TAMPING RAMMER**  
**(HONDA GX100RTKRB6 GASOLINE ENGINE)**

Revision #3 (04/26/21)

**THIS MANUAL MUST ACCOMPANY THE EQUIPMENT AT ALL TIMES.**

# TABLE OF CONTENTS

## MTR40HF Rammer

Explanation Of Code In Remarks Column.....	4
Suggested Spare Parts .....	5

## Rammer Component Drawings

Nameplates And Decals Assembly .....	6-7
Crankcase And Engine Assembly .....	8-11
Fuel Tank And Handle Assembly.....	12-13
Spring And Guide Cylinder Assembly .....	14-15
Foot Assembly .....	16-17
Foot (Option) Assembly .....	18-19

## Honda GX100RTKRB6 Gasoline Engine

Cylinder Barrel Assembly .....	20-21
Crankcase Cover Assembly .....	22-23
Crankshaft Assembly.....	24-25
Piston/Connecting Rod Assembly .....	26-27
Camshaft Pulley Assembly .....	28-29
Recoil Starter Assembly .....	30-31
Fan Cover Assembly.....	32-33
Carburetor Assembly .....	34-35
Air Cleaner Assembly .....	36-37
Muffler Assembly .....	38-39
Flywheel/Ignition Coil Assembly .....	40-41
Control Assembly .....	42-43
Label Assembly .....	44-45

### NOTICE

Specifications and part numbers are subject to change without notice.

# EXPLANATION OF CODE IN REMARKS COLUMN

The following section explains the different symbols and remarks used in the Parts section of this manual. Use the help numbers found on the back page of the manual if there are any questions.

**NOTICE**

The contents and part numbers listed in the parts section are subject to change **without notice**. Multiquip does not guarantee the availability of the parts listed.

## SAMPLE PARTS LIST

NO.	PART NO.	PART NAME	QTY.	REMARKS
1	12345	BOLT .....	1	INCLUDES ITEMS W/%
2%		WASHER, 1/4 IN. ....		NOT SOLD SEPARATELY
2%	12347	WASHER, 3/8 IN. ...	1	MQ-45T ONLY
3	12348	HOSE .....	A/R	MAKE LOCALLY
4	12349	BEARING .....	1	S/N 2345B AND ABOVE

## NO. Column

**Unique Symbols** — All items with same unique symbol (@, #, +, %, or >) in the number column belong to the same assembly or kit, which is indicated by a note in the “Remarks” column.

**Duplicate Item Numbers** — Duplicate numbers indicate multiple part numbers, which are in effect for the same general item, such as different size saw blade guards in use or a part that has been updated on newer versions of the same machine.

**NOTICE**

When ordering a part that has more than one item number listed, check the remarks column for help in determining the proper part to order.

## PART NO. Column

**Numbers Used** — Part numbers can be indicated by a number, a blank entry, or TBD.

TBD (To Be Determined) is generally used to show a part that has not been assigned a formal part number at the time of publication.

A blank entry generally indicates that the item is not sold separately or is not sold by Multiquip. Other entries will be clarified in the “Remarks” Column.

## QTY. Column

**Numbers Used** — Item quantity can be indicated by a number, a blank entry, or A/R.

A/R (As Required) is generally used for hoses or other parts that are sold in bulk and cut to length.

A blank entry generally indicates that the item is not sold separately. Other entries will be clarified in the “Remarks” Column.

## REMARKS Column

Some of the most common notes found in the “Remarks” Column are listed below. Other additional notes needed to describe the item can also be shown.

**Assembly/Kit** — All items on the parts list with the same unique symbol will be included when this item is purchased.

Indicated by:

“INCLUDES ITEMS W/(unique symbol)”

**Serial Number Break** — Used to list an effective serial number range where a particular part is used.

Indicated by:

“S/N XXXXX AND BELOW”

“S/N XXXX AND ABOVE”

“S/N XXXX TO S/N XXX”

**Specific Model Number Use** — Indicates that the part is used only with the specific model number or model number variant listed. It can also be used to show a part is NOT used on a specific model or model number variant.

Indicated by:

“XXXXX ONLY”

“NOT USED ON XXXX”

**“Make/Obtain Locally”** — Indicates that the part can be purchased at any hardware shop or made out of available items. Examples include battery cables, shims, and certain washers and nuts.

**“Not Sold Separately”** — Indicates that an item cannot be purchased as a separate item and is either part of an assembly/kit that can be purchased, or is not available for sale through Multiquip.

## SUGGESTED SPARE PARTS

---

### MTR40HF TAMPING RAMMER WITH HONDA GX100RTKRB6 GASOLINE ENGINE

#### 1 to 3 units

Qty.	P/N	Description
1.....	956100077.....	THROTTLE WIRE
3.....	362030030.....	ELEMENT, AIR CLEANER
1.....	361910070.....	CAP, FUEL TANK COMP.
3.....	16910GB2005 .....	FILTER, IN-LINE FUEL
3.....	9805655777.....	SPARK PLUG
1.....	28462Z0DV03.....	ROPE, RECOIL STARTER
3.....	17211ZL8023 .....	CLEANER, ELEMENT (ENGINE)

#### **NOTICE**

Part numbers on this Suggested Spare Parts list may supersede/replace the part numbers shown in the following parts lists.

# NAMEPLATES AND DECALS ASSY.

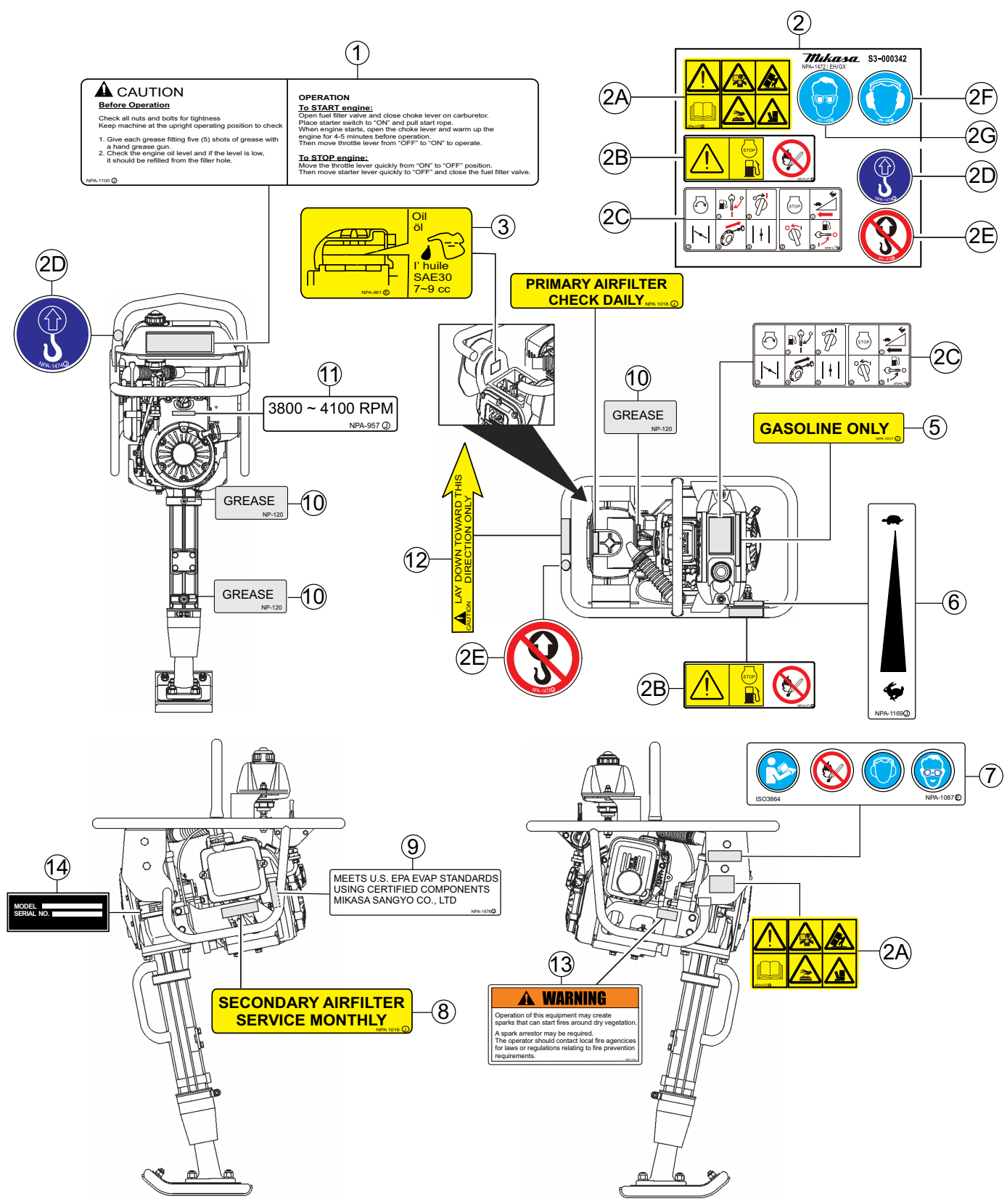

## NAMEPLATES AND DECALS ASSY.

<u>NO.</u>	<u>PART NO.</u>	<u>PART NAME</u>	<u>QTY.</u>	<u>REMARKS</u>
1	920211000	DECAL, CAUTION 4 CYCLE AND GREASE	1	
2	920900100	DECAL, SET, (NPA-1472).....	1	INCLUDES ITEMS W/#
2A#		DECAL, .....	1	NOT SOLD SEPARATELY
2B#		DECAL, CAUTION.....	1	NOT SOLD SEPARATELY
2C#		DECAL, OPERATION .....	1	NOT SOLD SEPARATELY
2D#		DECAL, LIFTING POSITION .....	1	NOT SOLD SEPARATELY
2E#		DECAL, DO NOT LIFT .....	1	NOT SOLD SEPARATELY
2F#		DECAL, DANGER HEARING PROTECTION ...	1	NOT USED
2G#		DECAL, DANGER EYE PROTECTION .....	1	NOT USED
3	920209610	DECAL, CLEANING ELEMENT.....	1	NPA-961
4	920210180	DECAL, CHECK DAILY, PRIMARY AIR FILTER ...	1	NPA-1018
5	920210170	DECAL, GASOLINE ONLY .....	1	NPA-1017
6	920211690	DECAL, LEVER OPERATION .....	1	NPA-1169
7	920210870	DECAL, CAUTION .....	1	NPA-1087
8	920210160	DECAL, SERVICE MONTHLY .....	1	NPA-1016
9	920216780	DECAL, EPA/EVAP COMPLIANT .....	1	NPA-1676
10	920101200	DECAL, GREASE .....	3	NP-120
11	920209570	DECAL, R.P.M.,3800-4100 .....	1	NPA-957
12	920206910	DECAL, LAY DOWN TOWARD DIRECTION	1	
13	920214100	DECAL, FIRE WARNING.....	1	NPA-1410
14		PLATE, SERIAL NO.....	1	CONTACT MQ PARTS DEPT.

# CRANKCASE AND ENGINE ASSY.

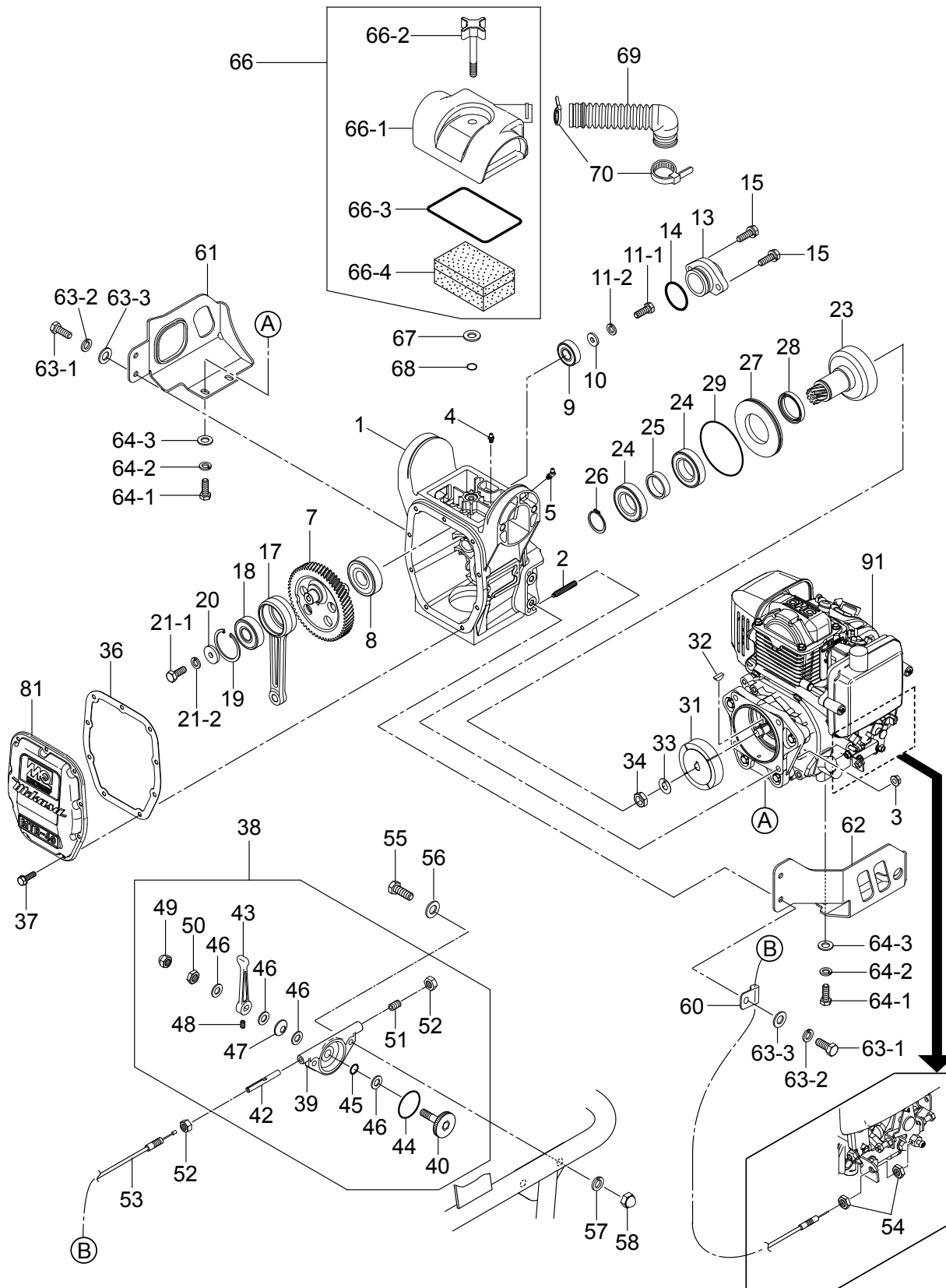

## CRANKCASE AND ENGINE ASSY.

<u>NO.</u>	<u>PART NO.</u>	<u>PART NAME</u>	<u>QTY.</u>	<u>REMARKS</u>
1	305117260	CRANKCASE	1	
2	959409790	SOCKET HEAD SCREW 8X50	4	
3	022910300	FLANGE NUT M8	4	
4	351010050	GREASE FITTING	1	
5	959010320	GREASE FITTING	1	
7	305343780	CRANK GEAR	1	
8	041006305	BEARING, 6305Z	1	
9	041006203	BEARING, 6203Z	1	
10	952401450	WASHER, 8.5X22X3	1	
11-1	011208025	BOLT 8X25.....	1	REPLACES P/N 001220825
11-2	030208200	WASHER, LOCK M8	1	
13	362455660	BEARING COVER	1	
14	050100350	O-RING	1	
15	002200620	BOLT, 6X20 MM, SOC. HD	2	
17	305333090	CONNECTING ROD	1	
18	042006304	BEARING 6304ZZ	1	
19	080100520	STOP RING	1	
20	952400130	WASHER	1	
21-1	011208025	BOLT 8X25.....	1	REPLACES P/N 001220825
21-2	030208200	WASHER, LOCK M8	1	
23	303010084	PINION	1	
24	042006007	BEARING 6007ZZ	2	
25	351437750	SPACER	1	
26	080200350	STOP RING	1	
27	351421900	SPACER, CLUTCH DRUM	1	
28	060504010	OIL SEAL	1	
29	050300900	O-RING	1	
31	361463840	CLUTCH ASSY.	1	
32	0053204201	WOODRUFF KEY	1	
33	301010210	LOCK WASHER, CLUTCH	1	
34	94002120000S	NUT M12	1	
36	362341610	PACKING, FRONT COVER	1	
37	002200620	BOLT 6X20 MM, SOC. HD	9	
38	362910060	THROTTLE LEVER ASSY. ....	1	INCLUDES ITEMS W/\$
39\$	362341550	THROTTLE BODY	1	
40\$	362910090	THROTTLE, GEAR COMP., W/BOLT	1	
42\$	362455620	SLIDER	1	
43\$	362455630	THROTTLE LEVER	1	
44\$	050100450	O-RING	1	
45\$	050200100	O-RING	1	
46\$	031110160	WASHER, FLAT M10	4	
47\$	032210220	WASHER, CONICAL SPRING M10	1	
48\$	096206006	SOCKET HEAD SCREW 6X6	1	
49\$	022131008	CAP NUT M10	1	
50\$	020310080	NUT M10 .....	1	REPLACES P/N 020410060



# CRANKCASE AND ENGINE ASSY. CONT'D.

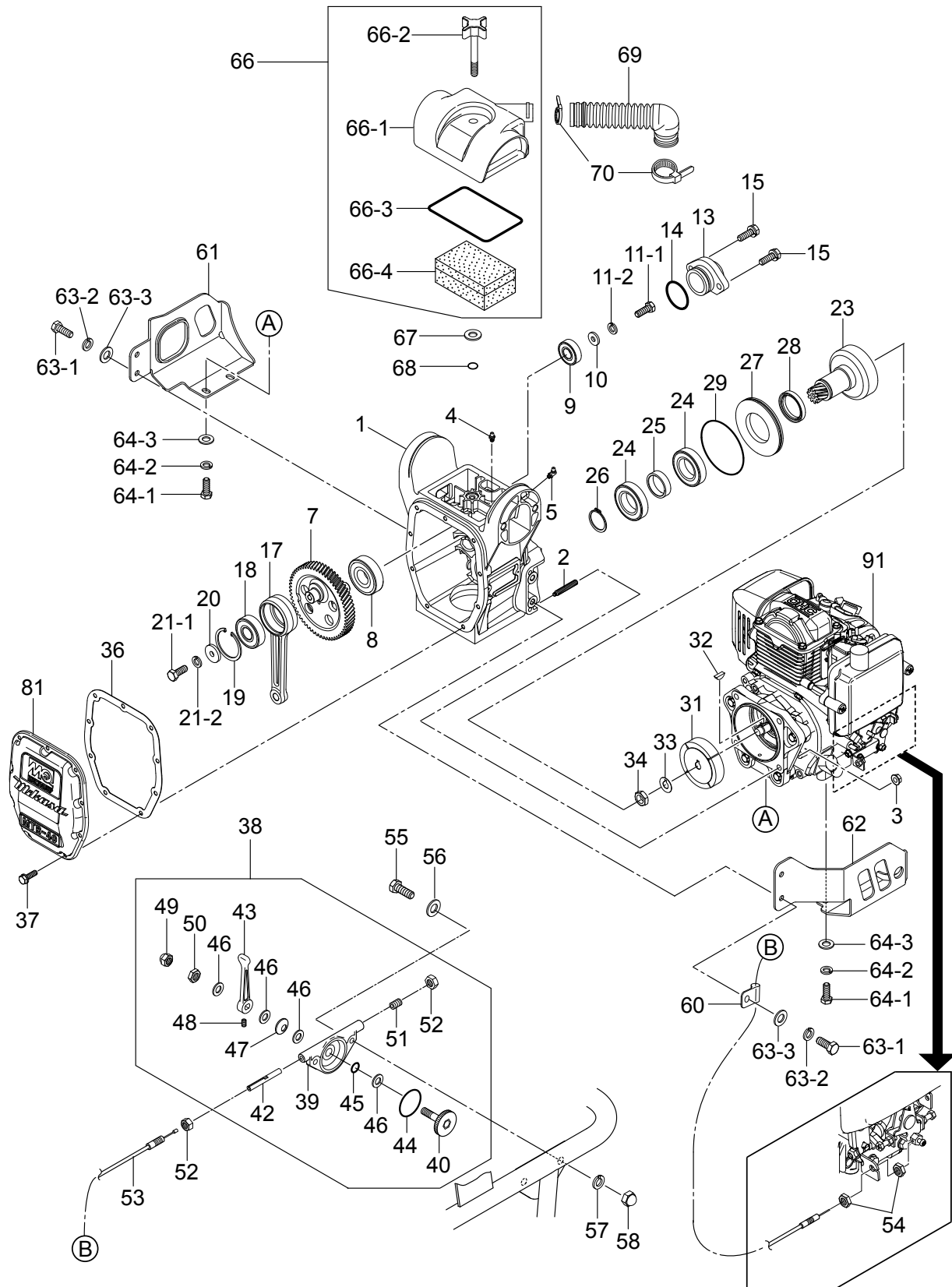

## CRANKCASE AND ENGINE ASSY. CONT'D.

<u>NO.</u>	<u>PART NO.</u>	<u>PART NAME</u>	<u>QTY.</u>	<u>REMARKS</u>
51\$	096208020	SOCKET HEAD SCREW 8X20	1	
52\$	020408050	NUT, SPECIAL 8 MM	2	
53	956100077	THROTTLE WIRE	1	
54	020406040	NUT M6	2	
55	011206020	BOLT 6X20.....	2	REPLACES P/N 001220620
56	952404470	WASHER, FLAT M6.....	2	REPLACES P/N 031106100
57	030206150	WASHER, LOCK M6	2	
58	022130605	NUT, CAP M6	2	
60	959006120	CLIP	1	
61	356354880	OIL GAUGE PROTECTOR	1	
62	356354870	LINK PROTECTOR	1	
63-1	001220820	BOLT 8X20	4	
63-2	030208200	WASHER, LOCK M8	4	
63-3	0401450080	WASHER, FLAT M8.....	4	REPLACES P/N 031108160
64-1	011208025	BOLT 8X25.....	4	REPLACES P/N 001220825
64-2	030208200	WASHER, LOCK M8	4	
64-3	0401450080	WASHER, FLAT M8.....	4	REPLACES P/N 031108160
66	362116871	AIR CLEANER ASSY.....	1	INCLUDES ITEMS W/#
66-1#	362030011	COVER COMP., AIR CLEANER	1	
66-2#	362030040	GRIP BOLT COMP., AIR CLEANER	1	
66-3#	362030020	PACKING, AIR CLEANER	1	
66-4#	362030030	ELEMENT, AIR CLEANER	1	
67	0401450080	WASHER, FLAT M8.....	1	REPLACES P/N 031108160
68	050300070	O-RING	1	
69	353342400	INTAKE PIPE	1	
70	507010110	CLAMP	2	
81	307010110	FRONT COVER	1	
91	912210028	ENGINE ASSY., GX100RTKRB6	1	

# FUEL TANK AND HANDLE ASSY.

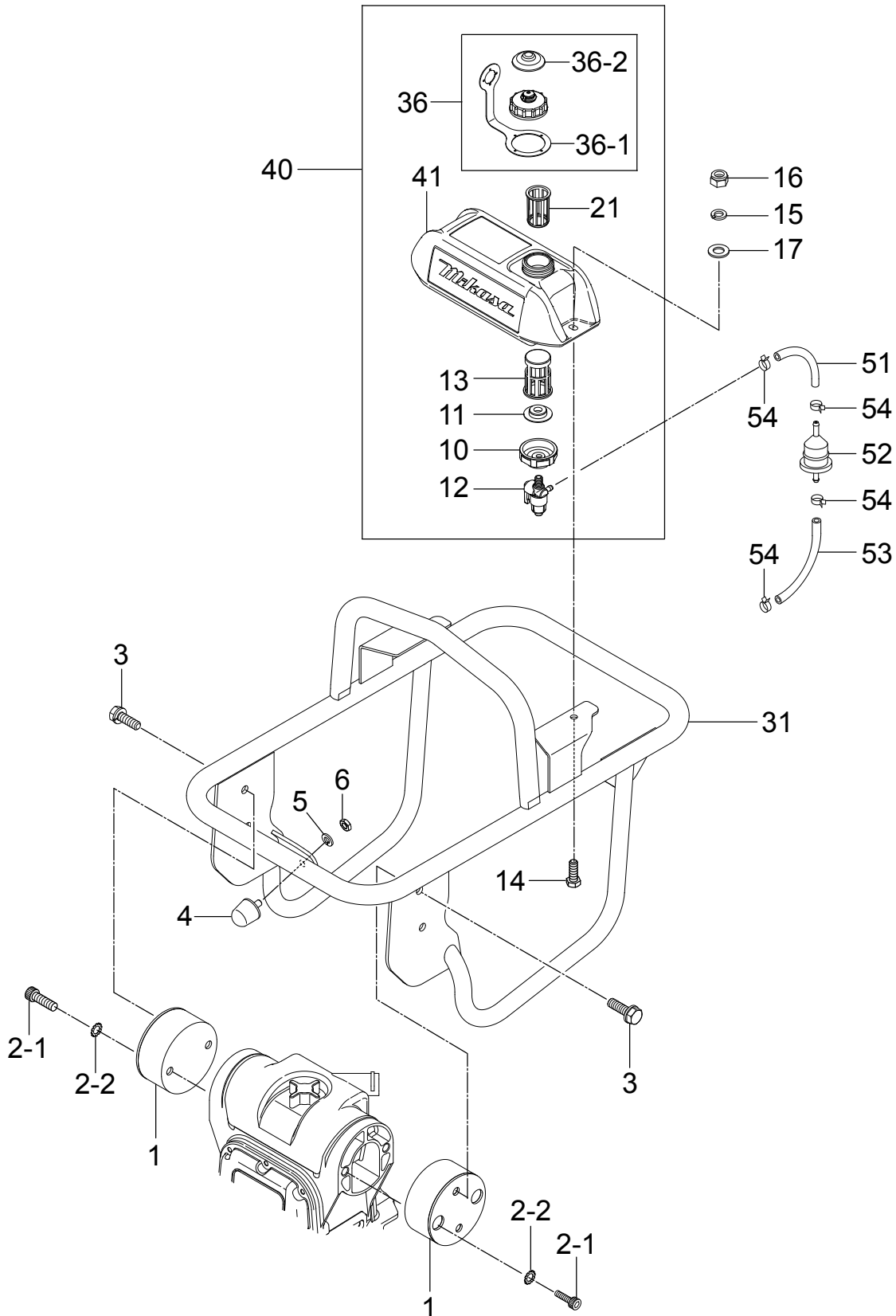

## FUEL TANK AND HANDLE ASSY.

<u>NO.</u>	<u>PART NO.</u>	<u>PART NAME</u>	<u>QTY.</u>	<u>REMARKS</u>
1	351319900	SHOCK ABSORBER	2	
2-1	014210020	SOCKET HEAD BOLT 10X20.....	4.....	REPLACES P/N 001521020
2-2	033121009	TOOTHED LOCK WASHER B M10	4	
3	012210020	BOLT 10X20 H, SW .....	4.....	REPLACES P/N 002211020
4	939010210	STOPPER RUBBER	1	
5	030208200	WASHER, LOCK M8	1	
6	020108060	NUT M8 .....	1.....	REPLACES P/N 020308060
10#	351437785	HOLDER, COCK	1	
11#	954406020	PACKING, FUEL TANK	1	
12#	954300720	FUEL COCK ASSY.	1	
13#	954406010	STRAINER (#110)	1	
14	011208030	BOLT 8X30.....	2.....	REPLACES P/N 001220830
15	030208200	WASHER, LOCK M8	2	
16	022710809	NYLON NUT M8	2	
17	952401450	WASHER 8.5X22X3	2	
21#	954407840	STRAINER (#80)	1	
31	306117960	HANDLE	1	
36#	361910070	CAP, FUEL TANK COMP. (ORANGE) .....	1.....	REPLACES P/N 361910021 INCLUDES ITEMS W/\$
36-1#\$	353449010	STRAP, OIL TANK CAP	1	
36-2#\$	362458350	SUB CAP, BLACK	1	
40	305910037	FUEL TANK ASSY. 2L (EVP) .....	1.....	INCLUDES ITEMS W/#
41#	363218261	FUEL TANK, 2L (EVAPO)	1	
51	91434Z4E812	FUEL HOSE, 5.5X11.5X80.....	1.....	REPLACES P/N 959026103
52	16910GB2005	FILTER, IN-LINE FUEL	1	
53	34479	FUEL HOSE, 1M.....	1.....	REPLACES P/N 950014500150M
54	H950024085008	CLAMP, TUBE.....	4.....	REPLACES P/N 950024085008

# SPRING AND GUIDE CYLINDER ASSY.

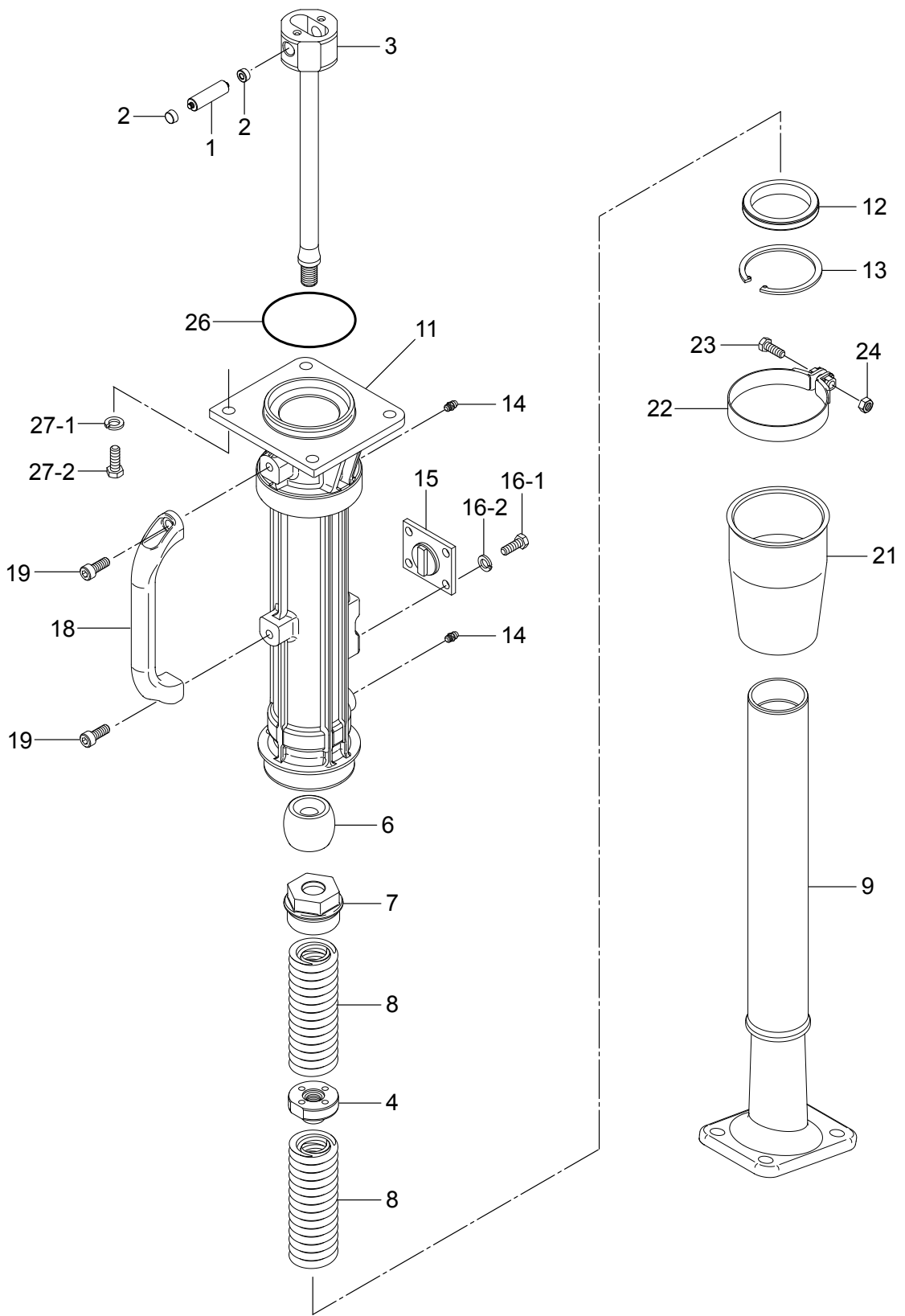

## SPRING AND GUIDE CYLINDER ASSY.

<u>NO.</u>	<u>PART NO.</u>	<u>PART NAME</u>	<u>QTY.</u>	<u>REMARKS</u>
1	305464130	PISTON PIN	1	
2	368459920	PISTON PIN PLUG	1	
3	305337982	PISTON ROD, M14	1	
4	305451550	PISTON END, M14	1	
6	305446400	STOPPER, UPPER	1	
7	305446410	CYLINDER CAP	1	
8	305446420	MAIN SPRING	2	
9	307219790	SPRING CYLINDER	1	
11	305112730	GUIDE CYLINDER	1	
12	065105010	DUST SEAL	1	
13	080510680	STOP RING	1	
14	351010050	GREASE FITTING	2	
15	305446430	STOPPER	1	
16-1	011008015	BOLT 8X15.....	4	REPLACES P/N 001220815
16-2	030208200	WASHER, LOCK 8 MM	4	
18	305446440	GRIP	1	
19	001520815	SOCKET HEAD BOLT 8X15	2	
21	305446450	DUST SLEEVE	1	
22	305446460	SLEEVE BAND	1	
23	011208035	BOLT 8X35.....	1	REPLACES P/N 001220835
24	020108060	NUT M8.....	1	REPLACES P/N 020308060
26	050100800	O-RING	1	
27-1	0105091025	BOLT 10X25.....	4	REPLACES P/N 001221025
27-2	030210250	WASHER, LOCK M10	4	

**FOOT ASSY.**

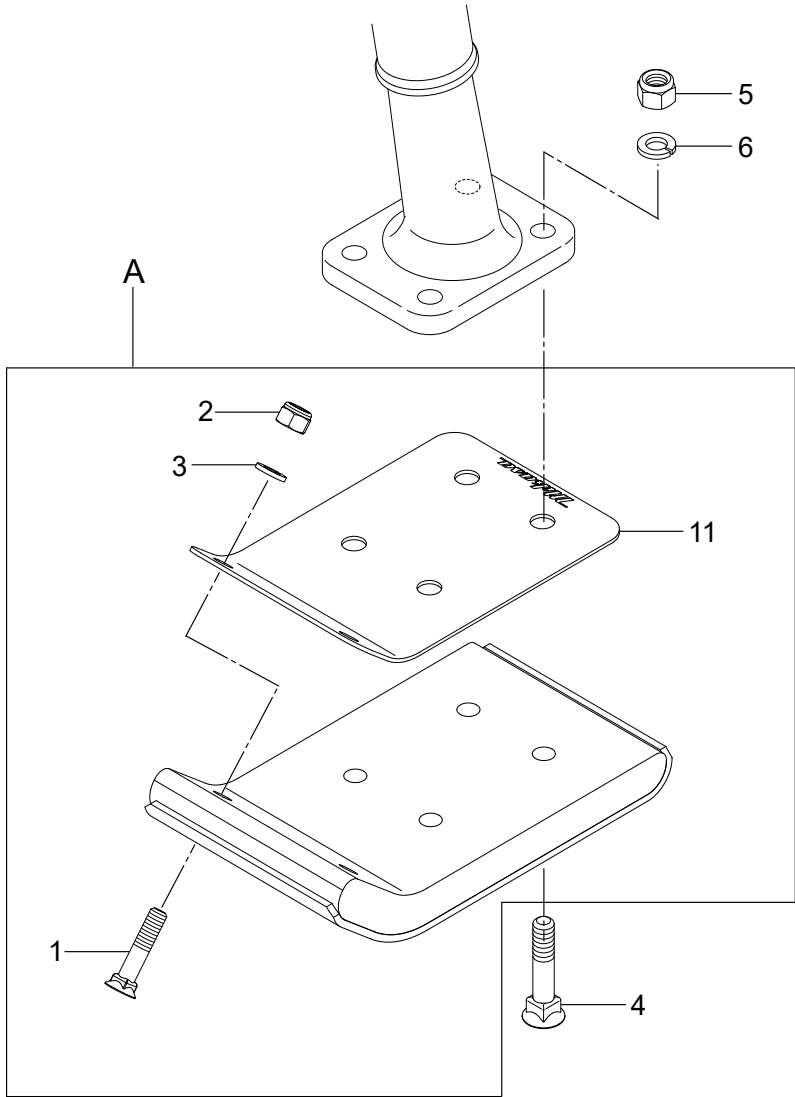

## FOOT ASSY.

---

<u>NO.</u>	<u>PART NO.</u>	<u>PART NAME</u>	<u>QTY.</u>	<u>REMARKS</u>
A	305910050	FOOT ASSY., 150B.....	1.....	INCLUDES ITEMS W/\$
1\$	009110033	BOLT, SQUARE NECK 10X50	2	
2\$	021110120	NYLON NUT M10 .....	2.....	REPLACES P/N 022711012
3\$	030210250	WASHER, LOCK M10	2	
4	009110034	BOLT, SQUARE NECK 12X65	4	
5	021112140	NYLON NUT M12 .....	4.....	REPLACES P/N 022711214
6	030212300	WASHER, LOCK M12	4	
11\$	306461630	FOOT COVER, 140	1	



# FOOT (OPTION) ASSY.

A

100 mm WIDTH

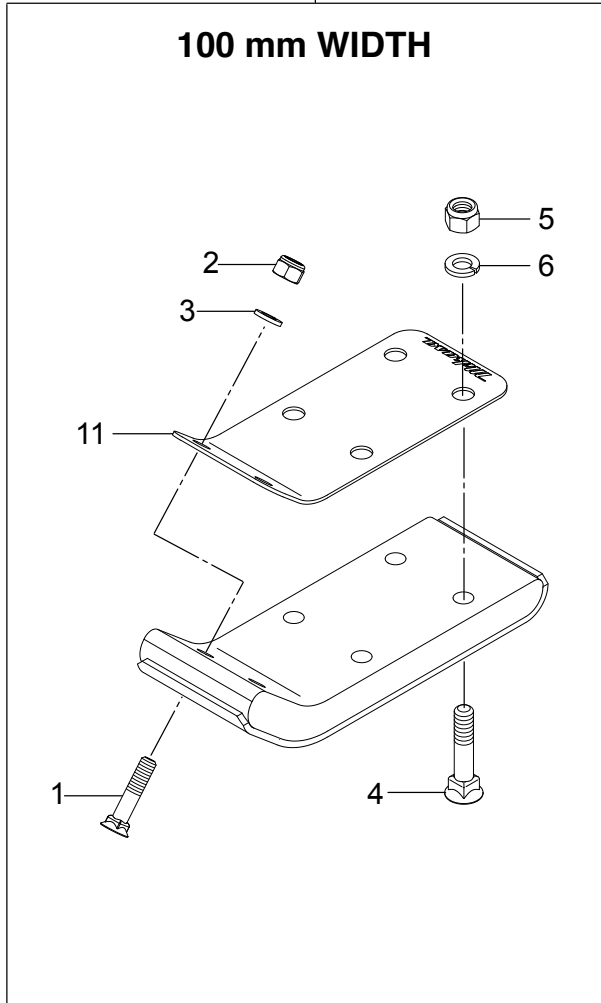

B

200 mm WIDTH

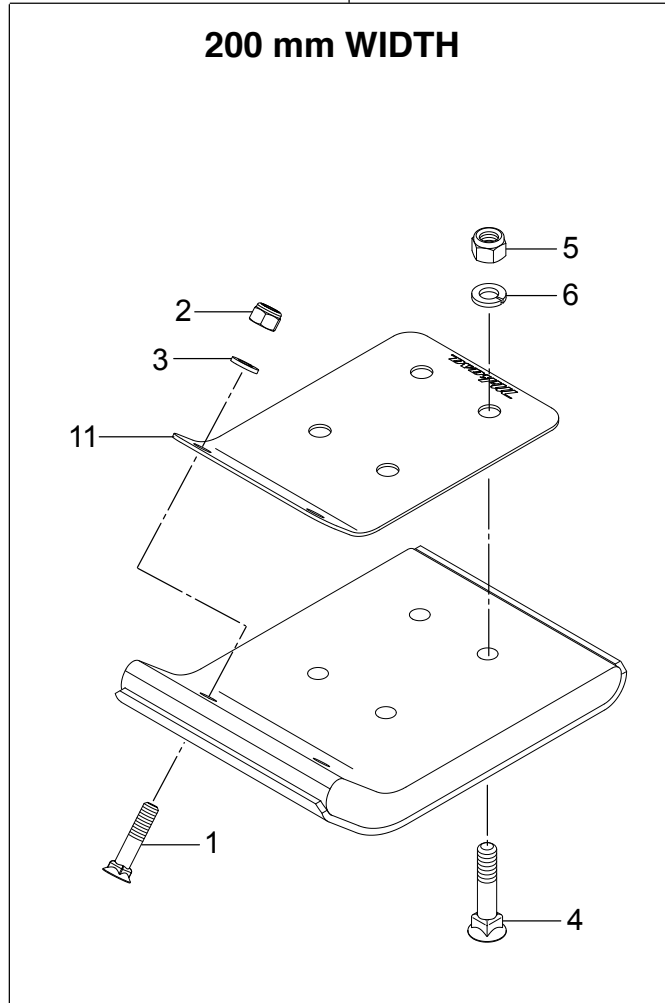

## FOOT (OPTION) ASSY.

---

<u>NO.</u>	<u>PART NO.</u>	<u>PART NAME</u>	<u>QTY.</u>	<u>REMARKS</u>
A	305910070	FOOT ASSY. 100B.....	1.....	INCLUDES ITEMS W/#
B	305910060	FOOT ASSY. 200B.....	1.....	INCLUDES ITEMS W/\$
1#\$	009110033	BOLT, SQUARE NECK 10X50	2	
2#\$	021110120	NUT, NYLON M10.....	2.....	REPLACES P/N 022711012
3#\$	030210250	WASHER, LOCK M10	2	
4#\$	009110034	BOLT, SQUARE NECK 12X65	4	
5#\$	021112140	NUT, NYLON M12.....	4.....	REPLACES P/N 022711214
6#\$	030212300	WASHER, LOCK 12 MM	4	
11#	306461620	FOOT COVER, 96B.....	1.....	100B
11\$	306461630	FOOT COVER, 140.....	1.....	200B

# HONDA GX100RTKRB6 ENG. — CYLINDER BARREL ASSY.

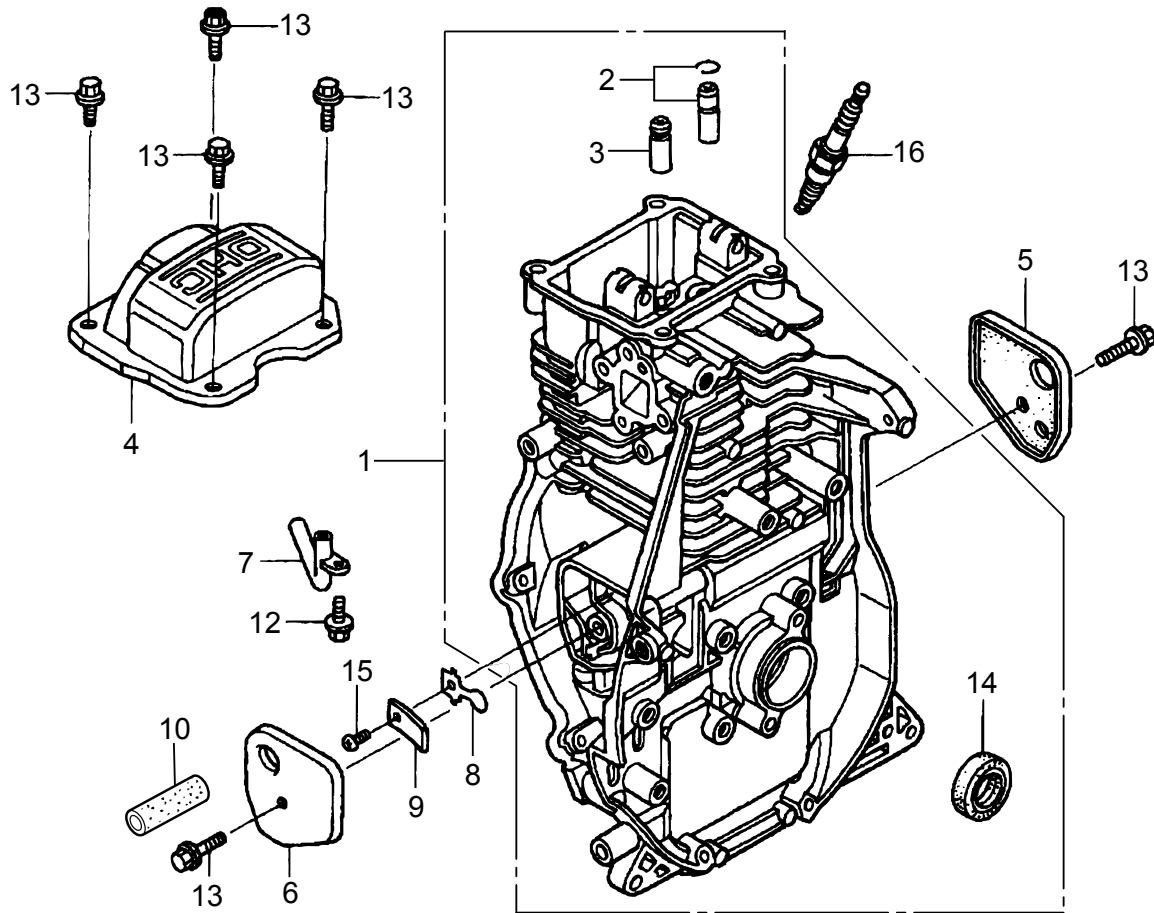

## HONDA GX100RTKRB6 ENG. — CYLINDER BARREL ASSY.

<u>NO.</u>	<u>PART NO.</u>	<u>PART NAME</u>	<u>QTY.</u>	<u>REMARKS</u>
1	12000Z0D405	BARREL ASSY., CYLINDER .....	1.....	INCLUDES ITEMS W/\$
2\$	12201Z0D305	GUIDE ASSY., EXHAUST VALVE (OS)	1	
3\$	12204Z0D305	GUIDE, INLET VALVE (O.S.)	1	
4	12311Z0D000	COVER, HEAD	1	
5	12355Z0D000	COVER COMPLETE A, BREATHER	1	
6	12365Z0D000	COVER COMPLETE B, BREATHER	1	
7	15171Z0DV00	PIPE, BREATHER	1	
8	15571Z0DV71	VALVE, OIL OUTLET	1	
9	15572ZM7000	PLATE, STOPPER	1	
10	15721Z0D000	TUBE, BREATHER	1	
12	90008ZM7000	BOLT 4X10	1	
13	90014952000	BOLT, FLANGE 6X14	6	
14\$	91202KJ9003	OIL SEAL 20X32X6	1	
15	93500030050A	SCREW, PAN 3X5	1	
16	9805655777	SPARK PLUG	1	

# HONDA GX100RTKRB6 ENG. — CRANKCASE COVER ASSY.

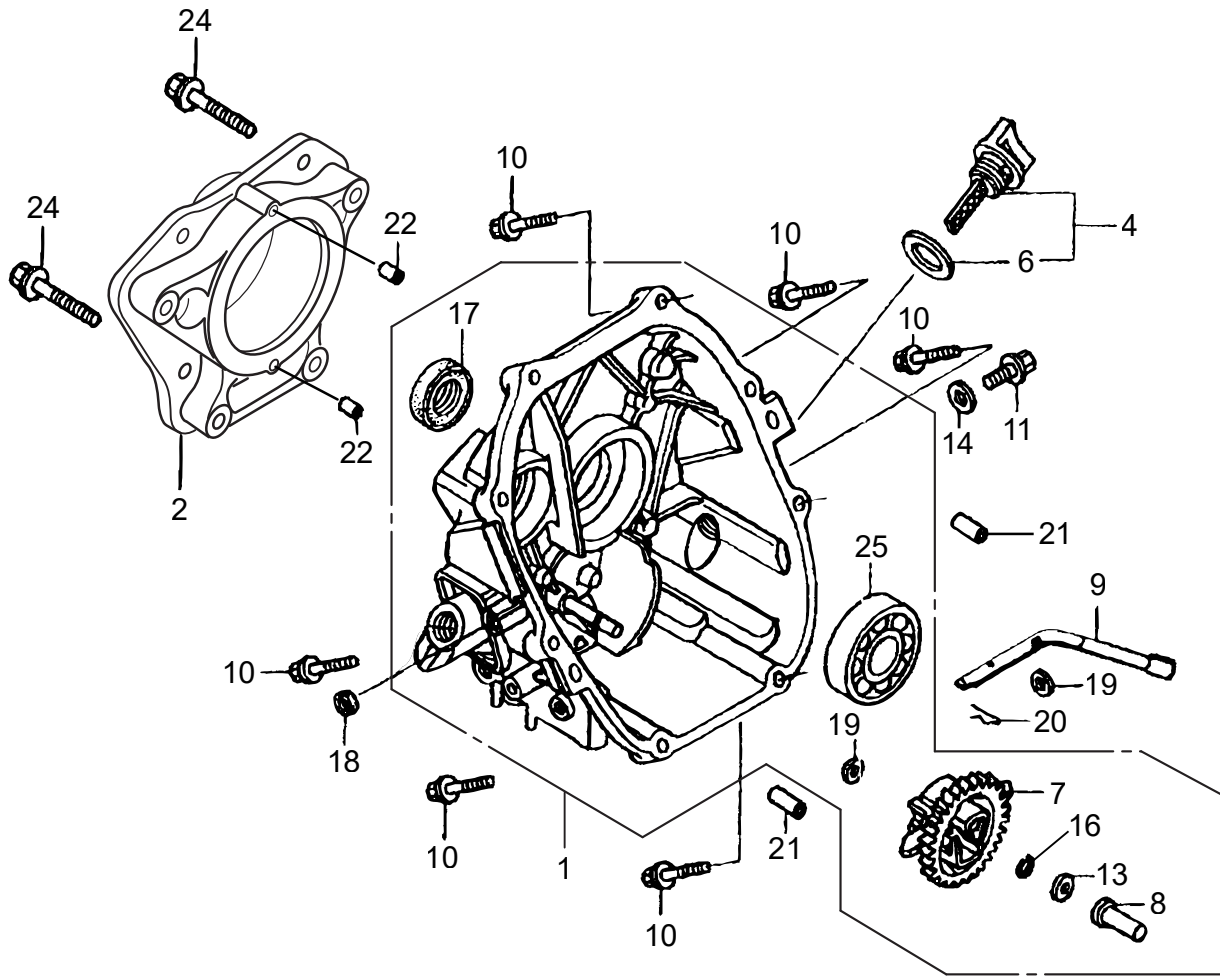

## HONDA GX100RTKRB6 ENG. — CRANKCASE COVER ASSY.

NO.	PART NO.	PART NAME	QTY.	REMARKS
1	11300Z0D409	COVER ASSY., CRANK CASE .....	1.....	INCLUDES ITEMS W/#
2	11511Z0DV00	FLANGE, P.T.O.	1	
4	15600ZDF000	CAP ASSY., OIL FILLER .....	1.....	INCLUDES ITEMS W/\$
6\$	15625Z0T800	PACKING, OIL FILLER CAP	1	
7#	16510ZL8000	GOVERNOR ASSY.	1	
8#	16531ZE1000	SLIDER, GOVERNOR	1	
9	16541Z0D000	SHAFT, GOVERNOR ARM	1	
10	957010602500	FLANGE BOLT 6X25 .....	8.....	REPLACES P/N 90121952000
11	90131ZE1000	BOLT, DRAIN PLUG	1	
13#	90451ZE1000	THRUST WASHER 6MM	1	
14	90601ZE1000	WASHER, DRAIN PLUG	1	
16#	90602ZE1000	CLIP, GOVERNOR HOLDER	1	
17#	91202KJ9003	OIL SEAL 20X32X6	1	
18	91231891003	OIL SEAL 6X11X4	1	
19	58176	WASHER, FLAT 6MM .....	2.....	REPLACES P/N 9410106800
20	9425108000	LOCK PIN 8MM	1	
21	9430108200	KNOCK PIN 8X20	2	
22	9430306100	KNOCK PIN 6X10	2	
24	957010804000	BOLT, FLANGE 8X40	4	
25#	91001Z0DV01	BEARING, RADIAL BALL	1	

# HONDA GX100RTKRB6 ENG. — CRANKSHAFT ASSY.

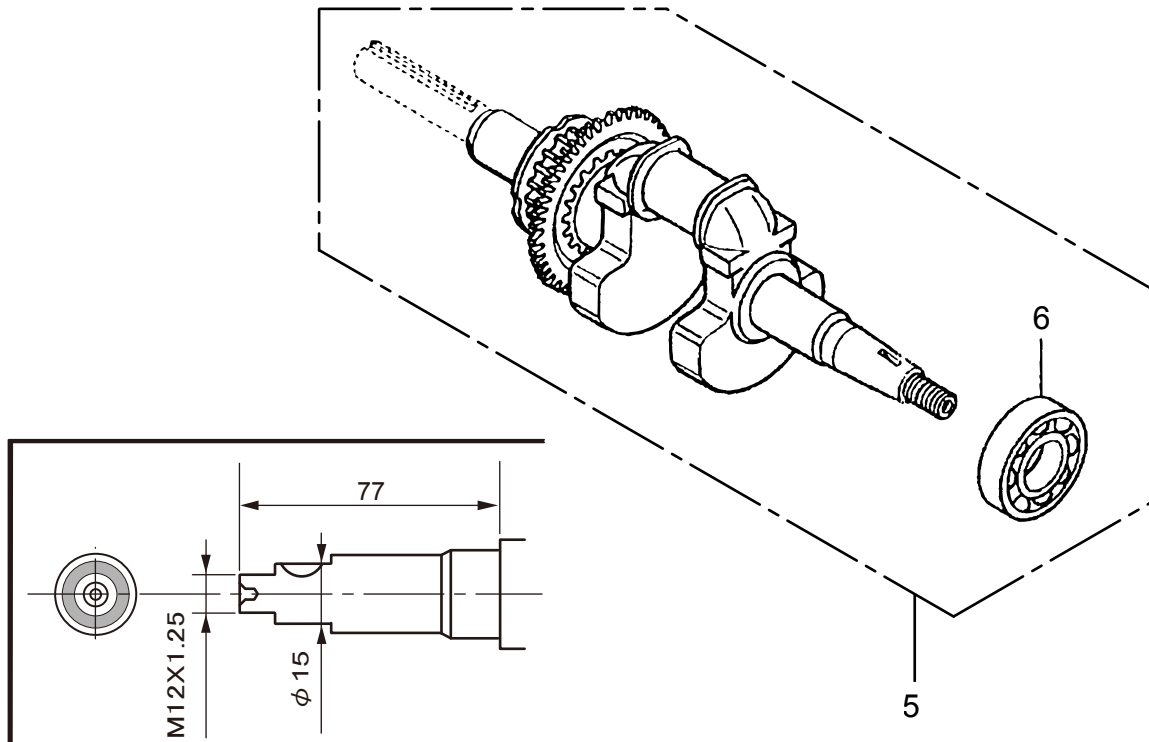

# HONDA GX100RTKRB6 ENG. — CRANKSHAFT ASSY.

---

<u>NO.</u>	<u>PART NO.</u>	<u>PART NAME</u>	<u>QTY.</u>	<u>REMARKS</u>
5	13310Z0DV00	CRANK SHAFT COMPLETE.....	1.....	INCLUDES ITEM W/\$
6\$	91001Z0DV01	BEARING, RADIAL BALL	1	



# HONDA GX100RTKRB6 ENG. — PISTON/CONN. ROD ASSY.

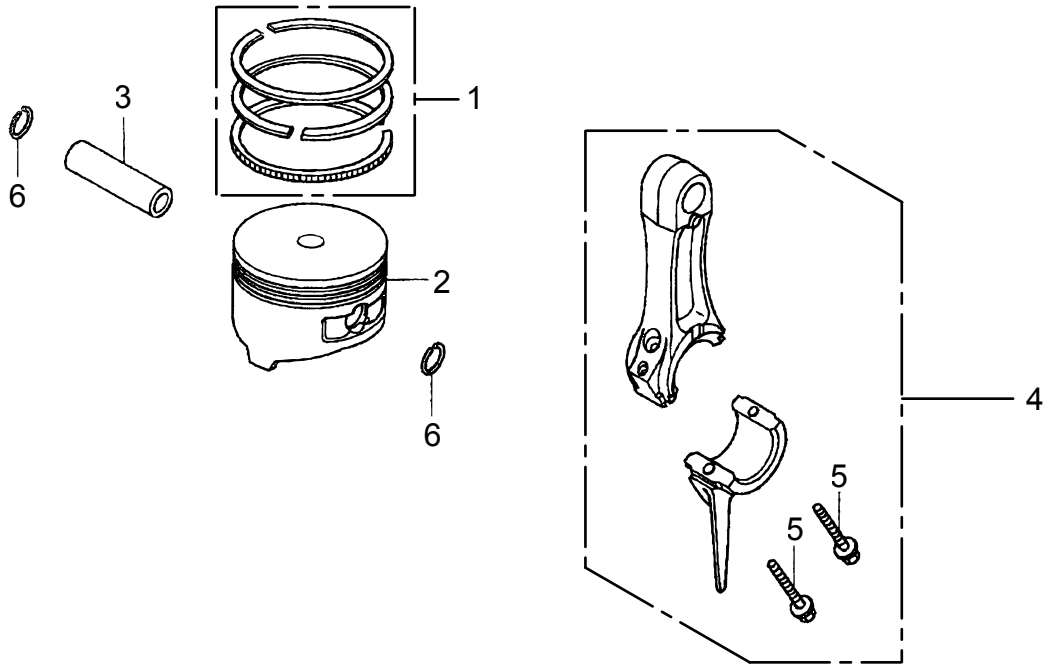

# HONDA GX100RTKRB6 ENG. — PISTON/CONN. ROD ASSY.

---

<u>NO.</u>	<u>PART NO.</u>	<u>PART NAME</u>	<u>QTY.</u>	<u>REMARKS</u>
1	13010Z0D003	RING SET, PISTON	1	
2	13101ZDD000	PISTON	1	
3	13111ZE0000	PISTON PIN	1	
4	13200Z0D000	CONNECTING ROD ASSY.....	1.....	INCLUDES ITEM W/#
5#	90001ZM7000	CONNECTING ROD BOLT	2	
6	90551ZE0000	CLIP, PISTON PIN 13MM	2	

# HONDA GX100RTKRB6 ENG. — CAMSHAFT PULLEY ASSY.

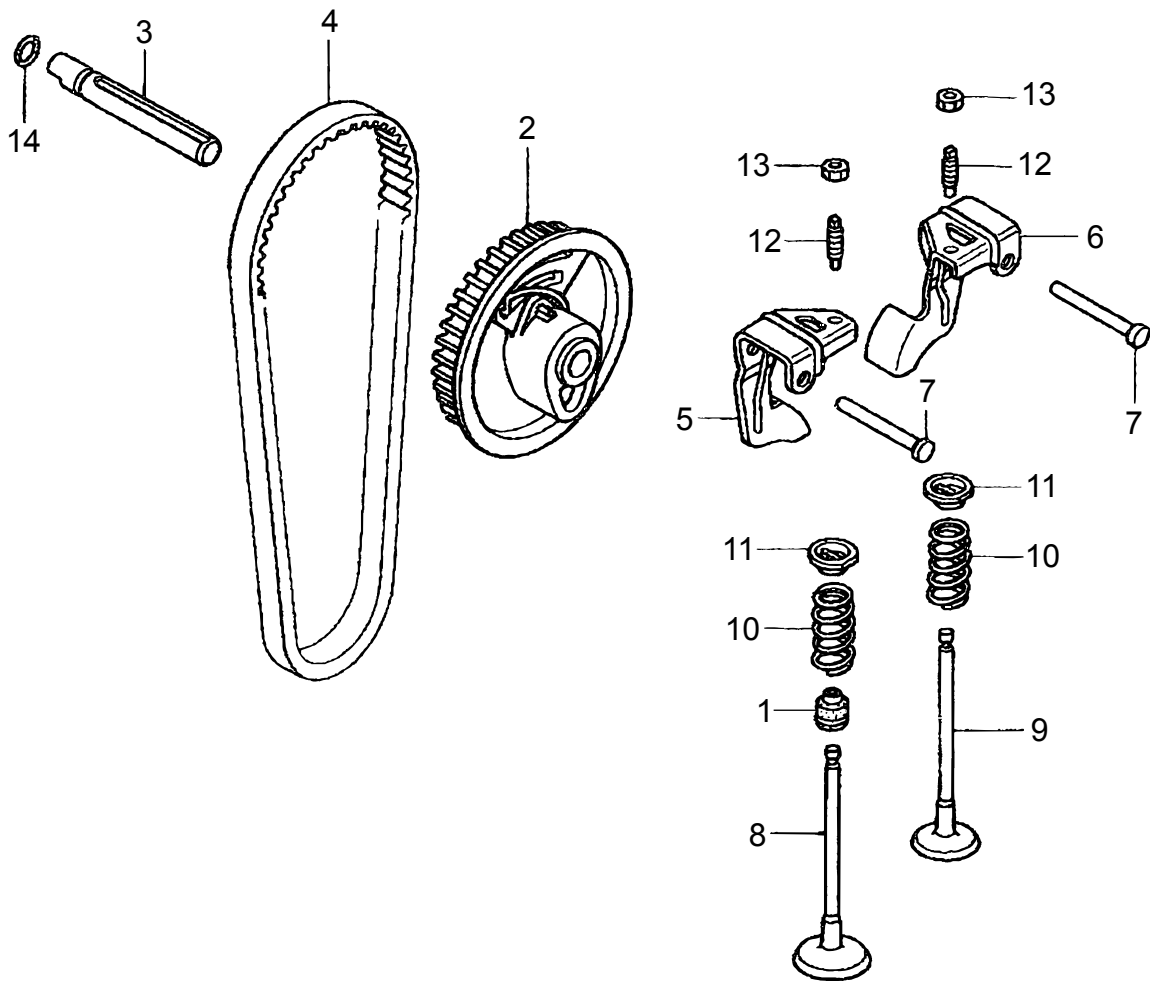

## HONDA GX100RTKRB6 ENG. — CAMSHAFT PULLEY ASSY.

---

<u>NO.</u>	<u>PART NO.</u>	<u>PART NAME</u>	<u>QTY.</u>	<u>REMARKS</u>
1	12209KT7013	SEAL, VALVE STEM	1	
2	14320ZDD000	PULLEY COMP., CAMSHAFT/RTE	1	
3	14324Z0D000	SHAFT, CAM PULLEY	1	
4	14400Z0D003	TIMING BELT	1	
5	14431ZDD000	ROCKER ARM, INTAKE VALVE	1	
6	14441ZDD000	ROCKER ARM, EXHAUST VALVE	1	
7	14461ZL8000	SHAFT, ROCKER ARM	2	
8	14711Z0D000	INLET VALVE	1	
9	14721Z0D000	EXHAUST VALVE	1	
10	14751Z0D000	SPRING, VALVE	2	
11	14771ZM3010	RETAINER, VALVE SPRING	2	
12	90012333000	SCREW, TAPPET ADJUSTING	2	
13	90206001000	NUT, TAPPET ADJUSTING	2	
14	91301ZM0V31	O-RING 6.8X1.9	1	

**HONDA GX100RTKRB6 ENG. — RECOIL STARTER ASSY.**

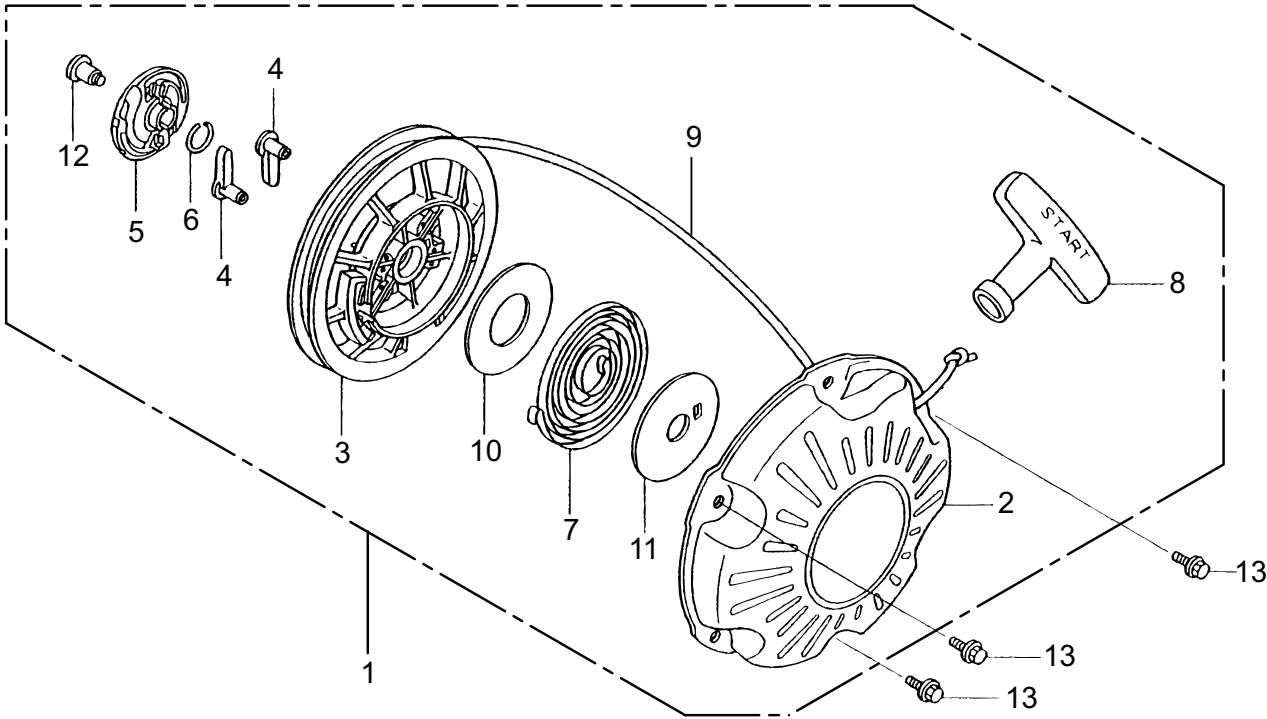

## HONDA GX100RTKRB6 ENG. — RECOIL STARTER ASSY.

<u>NO.</u>	<u>PART NO.</u>	<u>PART NAME</u>	<u>QTY.</u>	<u>REMARKS</u>
1	28400Z0DV04ZA	RECOIL STARTER ASSY. ....	1.....	INCLUDES ITEMS W/\$
2\$	28410Z0DV02ZA	CASE COMPLETE/RECOIL *5-3-5(B)	1	
3\$	28421ZDD003	REEL, RECOIL STARTER	1	
4\$	28422ZG0W02	RATCHET, STARTER	2	
5\$	28433ZG0W02	GUIDE, RATCHET	1	
6\$	28441ZW9003	SPRING, FRICTION .....	1.....	REPLACES P/N 28441ZW6003
7\$	28442ZH8003	SPRING, RECOIL STARTER	1	
8\$	28461ZDD003	KNOB, RECOIL STARTER	1	
9\$	28462Z0DV03	ROPE, RECOIL STARTER	1	
10\$	28467Z0DV02	PLATE, SIDE	1	
11\$	28468Z0DV02	PLATE, SLIDE	1	
12\$	90003ZH8003	SET SCREW	1	
13	957010600800	FLANGE BOLT 6X8	3	

# HONDA GX100RTKRB6 ENG. — FAN COVER ASSY.

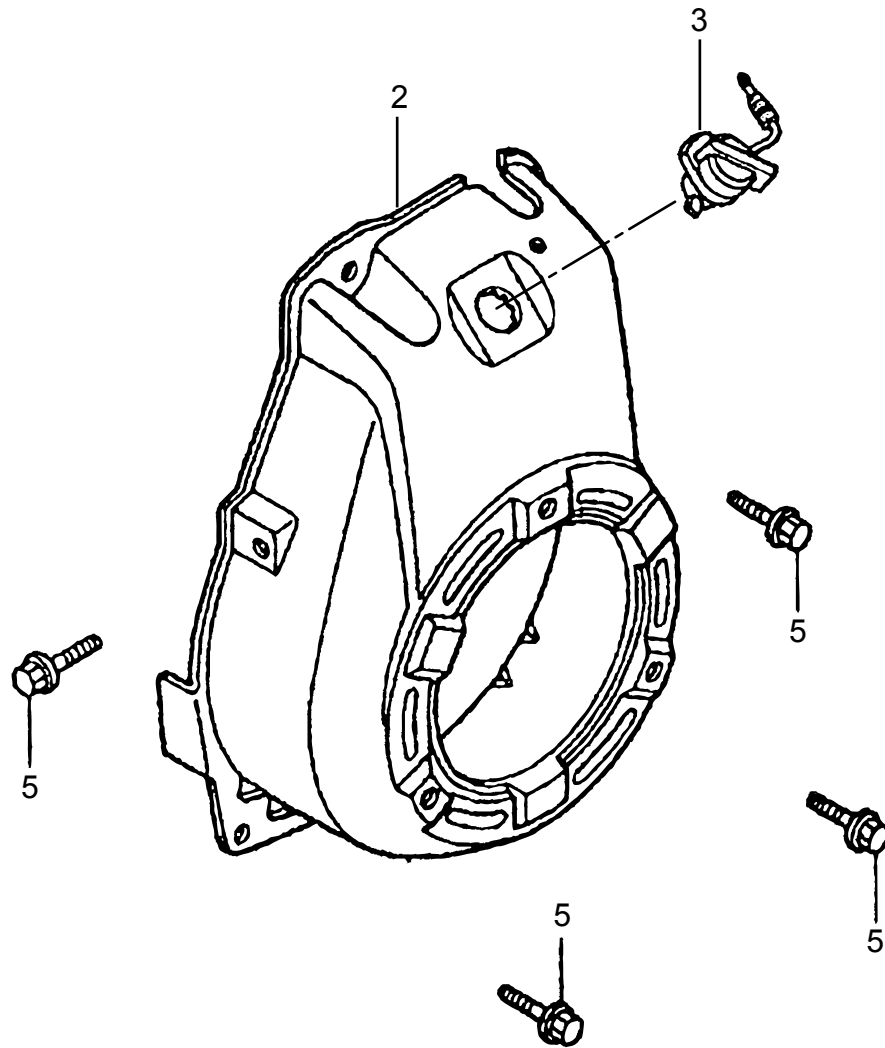

## HONDA GX100RTKRB6 ENG. — FAN COVER ASSY.

---

<u>NO.</u>	<u>PART NO.</u>	<u>PART NAME</u>	<u>QTY.</u>	<u>REMARKS</u>
2	19610Z0DV00ZB	FAN COVER COMPLETE, BLK.	1	
3	35120Z0DV81	SWITCH ASSY., ENGINE STOP/U	1	
5	90014952000	BOLT, FLANGE 6X14	4	



# HONDA GX100RTKRB6 ENG. — CARBURETOR ASSY.

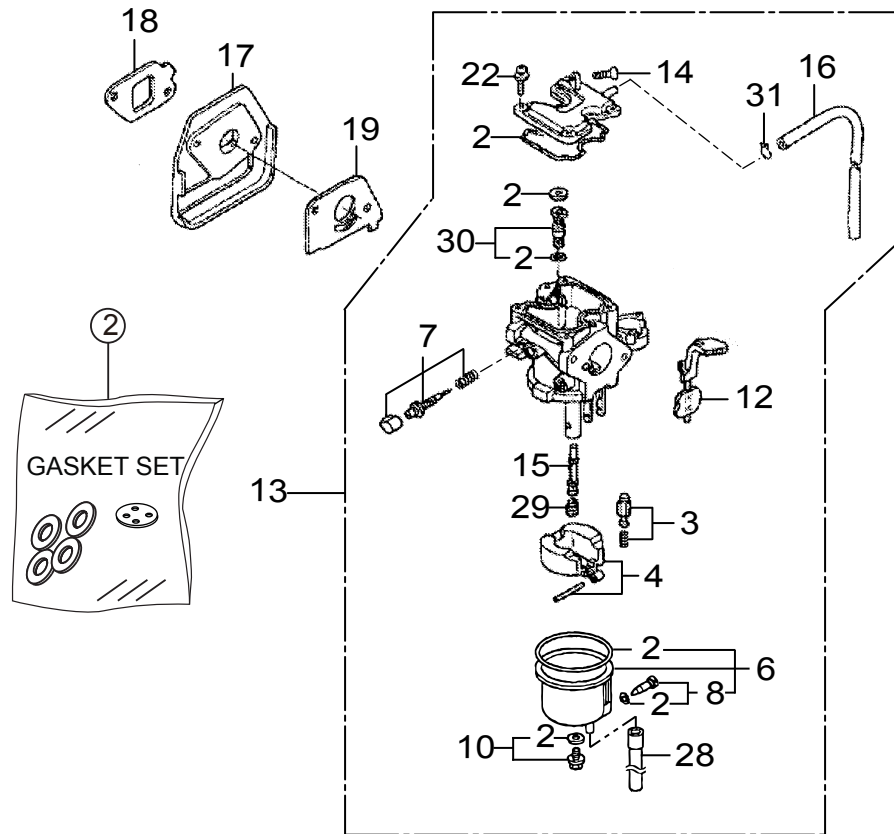

## NOTICE

Gasket set, item 2 included with items 6, 8, 10 and 30.

## HONDA GX100RTKRB6 ENG. — CARBURETOR ASSY.

<u>NO.</u>	<u>PART NO.</u>	<u>PART NAME</u>	<u>QTY.</u>	<u>REMARKS</u>
2\$%	16010Z4EW51	GASKET SET	1	
3\$	16011ZDJ851	VALVE SET, FLOAT	1	
4\$	16013ZG0811	FLOAT SET	1	
6\$	16015Z4EW51	FLOAT CHAMBER SET .....	1	INCLUDES ITEM W/%
7\$	16016Z0DV21	SCREW SET	1	
8\$	16024124760	SCREW SET, DRAIN .....	1	INCLUDES ITEM W/%
10\$	16028ZC0005	SCREW SET .....	1	INCLUDES ITEM W/%
12\$	16044Z0DV21	LEVER SET, CHOKE	1	
13	16100Z4EV11	CARBURETOR ASSY.....	1	INCLUDES ITEMS W/\$
14\$	16124ZE0005	SCREW, THROTTLE STOP	1	
15\$	16166Z0D003	MAIN NOZZLE	1	
16\$	16199Z0DV21	TUBE, VENT	1	
17	16211Z0D010	INSULATOR, CARBURETOR	1	
18	16212Z0DV20	PACKING, INSULATOR	1	
19	16221ZG0801	PACKING, CARBURETOR	1	
22\$	938920401208	SCREW-WASHER, 4X12	4	
28\$	950030501931	TUBE, VINYL, 3.5X6.5X190	1	
29\$	99101ZG00580	JET, MAIN #58	1	
30\$	99204ZE00350	PILOT JET SET #35 .....	1	INCLUDES ITEM W/%
31\$	9500202089	CLIP, TUBE	1	

# HONDA GX100RTKRB6 ENG. — AIR CLEANER ASSY.

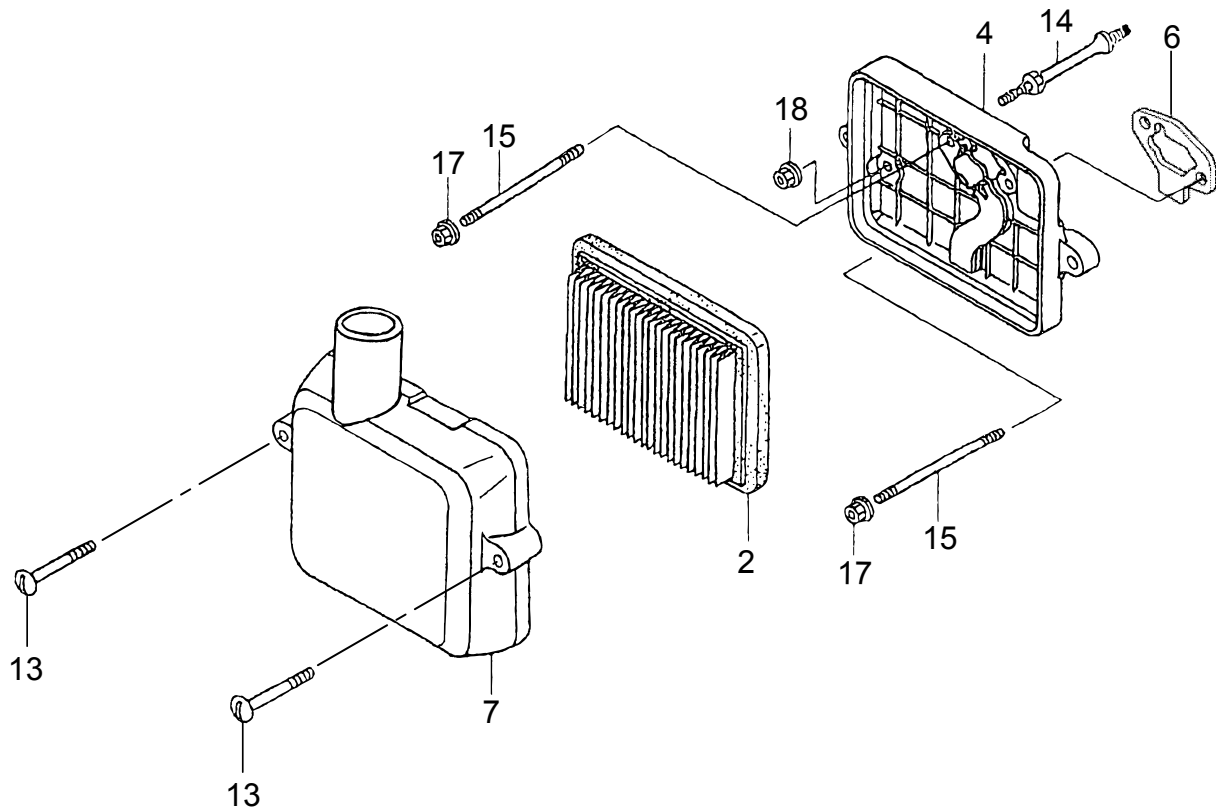

## HONDA GX100RTKRB6 ENG. — AIR CLEANER ASSY.

---

<u>NO.</u>	<u>PART NO.</u>	<u>PART NAME</u>	<u>QTY.</u>	<u>REMARKS</u>
2	17211ZL8023	CLEANER, ELEMENT	1	
4	17220Z0DV22	CASE COMPLETE, AIR CLEANER	1	
6	17228Z0DV21	PACKING, AIR CLEANER	1	
7	17231Z0DV62	COVER, AIR CLEANER	1	
13	90011Z0D000	BOLT, AIR CLEANER COVER	2	
14	90041Z0DV20	STUD BOLT	1	
15	90042Z0DV20	STUD BOLT 5X75	2	
17	9405005000	FLANGE NUT 5MM	2	
18	9405006000	FLANGE NUT 6MM	1	

# HONDA GX100RTKRB6 ENG. — MUFFLER ASSY.

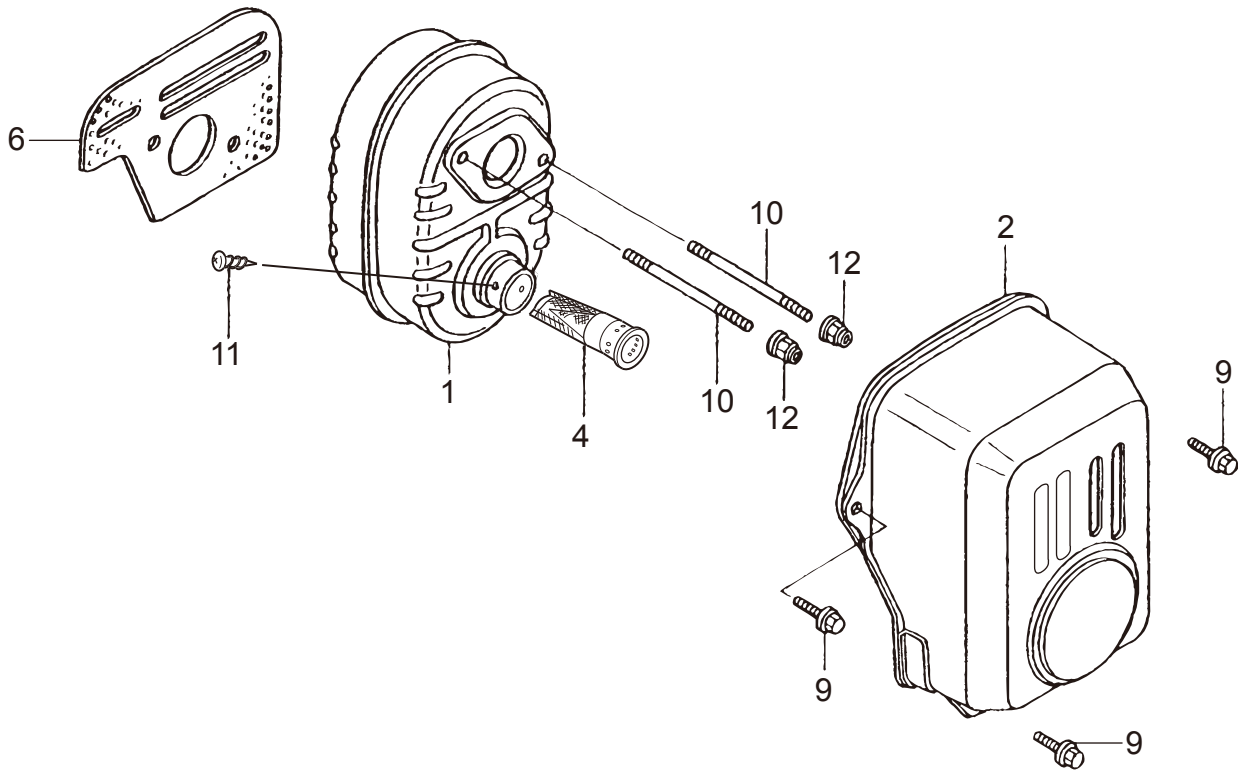

## HONDA GX100RTKRB6 ENG. — MUFFLER ASSY.

---

<u>NO.</u>	<u>PART NO.</u>	<u>PART NAME</u>	<u>QTY.</u>	<u>REMARKS</u>
1	18310ZDD810	MUFFLER COMPLETE	1	
2	18321Z0DV22	MUFFLER PROTECTOR	1	
4	18350ZL8000	ARRESTER COMP., SPARK/RT-E	1	
6	18381Z0D000	GASKET, MUFFLER	1	
9	90014952000	BOLT, FLANGE 6X14	3	
10	90048Z0DV00	STUD BOLT 6X78	2	
11	90055ZE1000	TAPPING SCREW 4X6	1	
12	90343ZE6000	NUT, SELF-LOCK 6 MM	2	

# HONDA GX100RTKRB6 ENG. — FLYWHEEL/IGN. COIL ASSY.

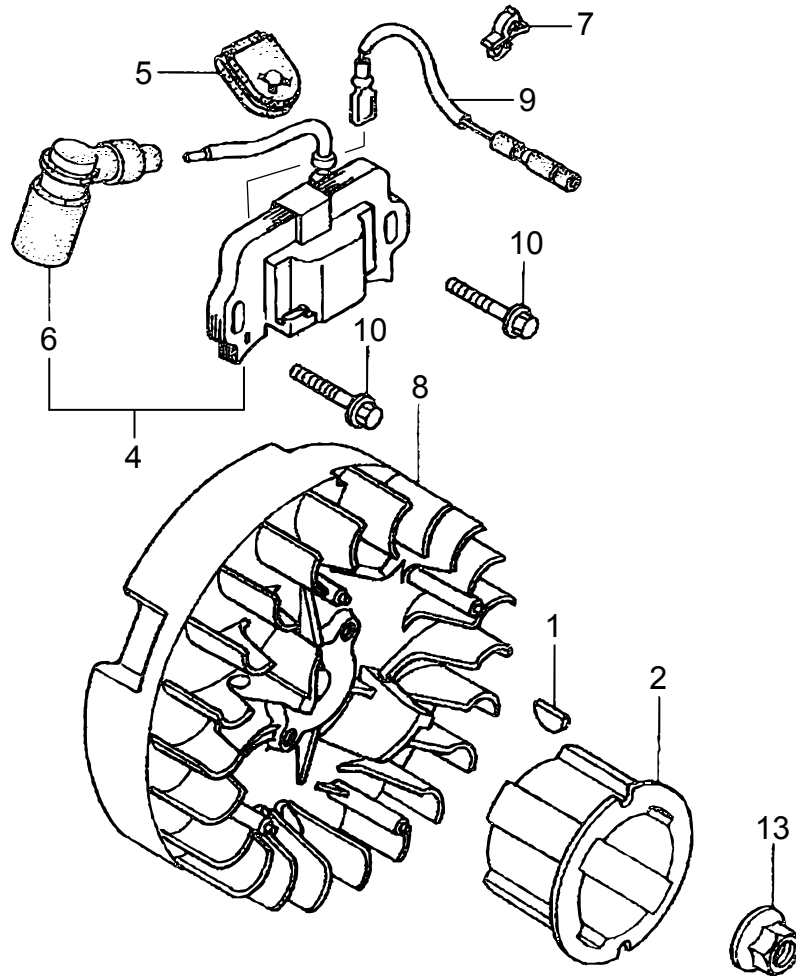

## **HONDA GX100RTKRB6 ENG. — FLYWHEEL/IGN. COIL ASSY.**

---

<u>NO.</u>	<u>PART NO.</u>	<u>PART NAME</u>	<u>QTY.</u>	<u>REMARKS</u>
1	13331ZM7000	WOODRUFF KEY 25X18	1	
2	28451Z0DV03	STARTER PULLEY	1	
4	30500Z0DV02	IGNITION COIL ASSY.....	1.....	INCLUDES ITEM W/#
5	30564ZA5000	GROMMET, CORD	1	
6#	30700Z0DV01	TERMINAL ASSY.	1	
7	30701883000	CLIP, HIGH TENSION CORD	1	
8	31110Z0D003	FLYWHEEL COMPLETE	1	
9	32195Z0D000	CORD, STOP SWITCH	1	
10	90022888010	FLANGE BOLT 6X20	2	
13	9405012000	FLANGE NUT M12	1	



# HONDA GX100RTKRB6 ENG. — CONTROL ASSY.

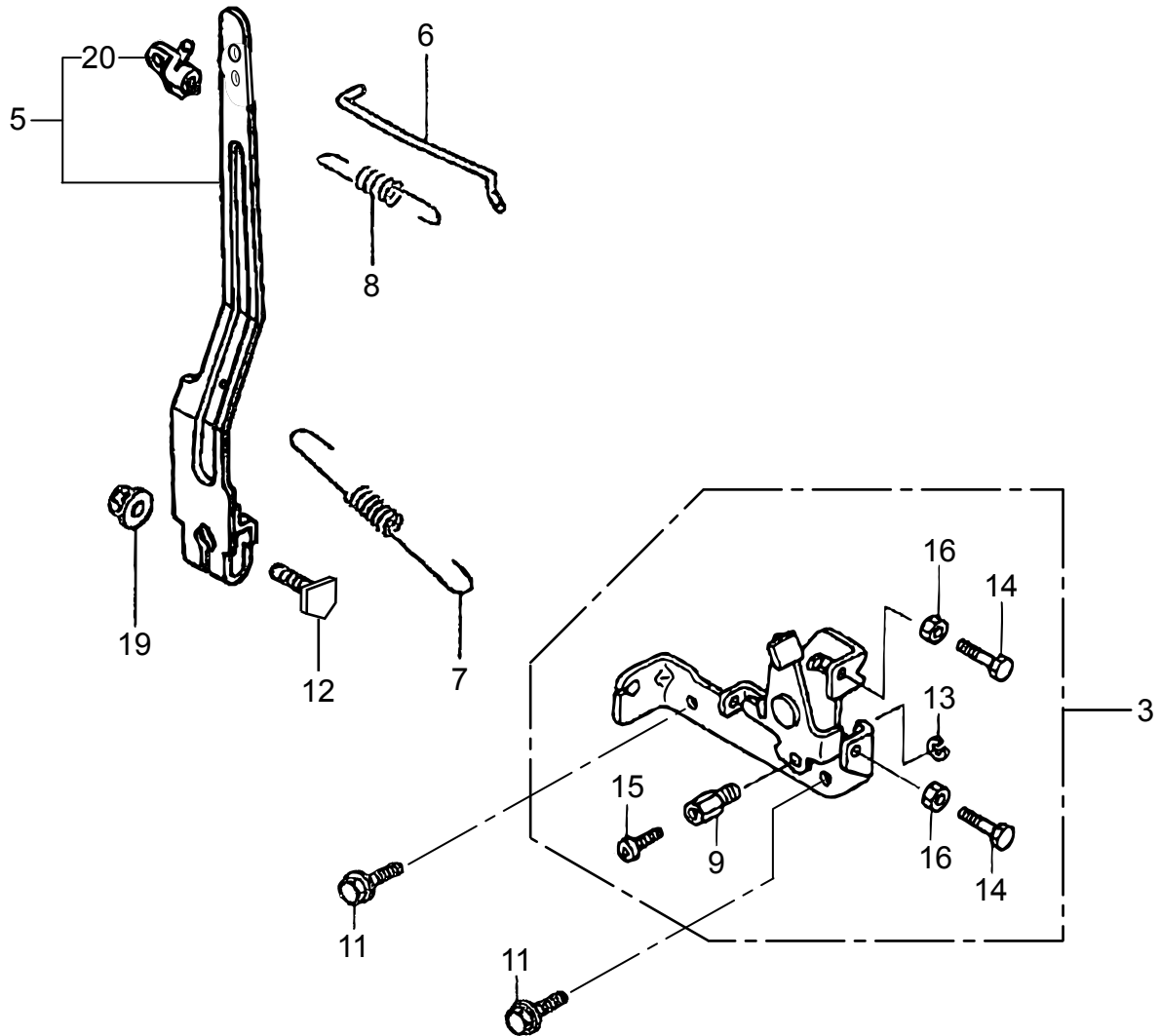

## HONDA GX100RTKRB6 ENG. — CONTROL ASSY.

<u>NO.</u>	<u>PART NO.</u>	<u>PART NAME</u>	<u>QTY.</u>	<u>REMARKS</u>
3	16500Z4ES30	CONTROL ASSY.....	1.....	INCLUDES ITEMS W/\$
5	16550Z0DV21	GOVERNOR ARM .....	1.....	INCLUDES ITEM W/#
6	16555Z0DV20	GOVERNOR ROD	1	
7	16561Z0DV20	GOVERNOR SPRING	1	
8	16562Z0DV20	SPRING, THROTTLE	1	
9\$	16594883010	HOLDER, WIRE	1	
11	90014952000	BOLT, FLANGE 6X14	2	
12	90015Z5T000	BOLT, GOVERNOR ARM	1	
13\$	90605230000	CIR CLIP	1	
14\$	92301050220A	BOLT 5X20.....	2.....	REPLACES P/N 92301050200A
15\$	0043504060	SCREW 4X6 .....	1.....	REPLACES P/N 93500040060H
16\$	940010500005	NUT M5.....	2.....	REPLACES P/N 9400105000
19	9405006000	FLANGE NUT 6MM	1	
20#	16263883W10	JOINT, ROD	1	

# HONDA GX100RTKRB6 ENG. — LABEL ASSY.

---

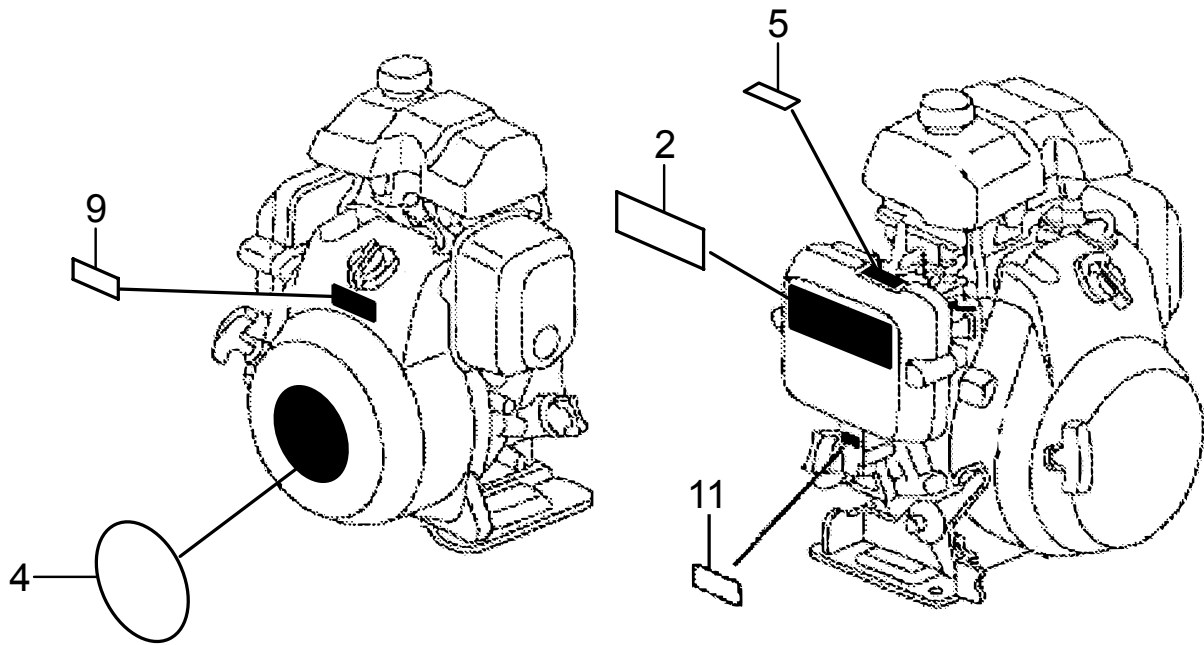

## HONDA GX100RTKRB6 ENG. — LABEL ASSY.

---

<u>NO.</u>	<u>PART NO.</u>	<u>PART NAME</u>	<u>QTY.</u>	<u>REMARKS</u>
2	87516ZDD000	MARK, OPERATOR CAUTION/ENG	1	
4	87521ZDDP10	EMBLEM (GX100) (RAMMER)	1	
5	87528Z0D000	MARK, CHOKE	1	
9	87539Z0J000	MARK, EX. CAUTION/PICTO	1	
11	87601ZDJV20	MARK, TYPE (KRB6)	1	