

# PARTS MANUAL



*Mikasa* **SERIES**  
**MODEL MT-86D2**  
**TAMPING RAMMER**  
**(YANMAR DIESEL ENGINE)**

Revision #4 (10/02/20)

THIS MANUAL MUST ACCOMPANY THE EQUIPMENT AT ALL TIMES.

# MT-86D2 TAMPING RAMMER — TABLE OF CONTENTS

## MIKASA MT-86D2 Tamping Rammer

Table Of Contents .....	3
Explanation Of Parts Section .....	4
Suggested Spare Parts .....	5
Name Plate And Decals .....	6-7
Crankcase and Engine Assembly .....	8-11
Guide Cylinder and Foot Assembly .....	12-13
Tank and Handle Assembly .....	14-15

## YANMARL-48V6 ENGINE

Cylinder Block Assembly .....	16-17
Cylinder Head Assembly .....	18-19
Crankshaft and Camshaft Assembly .....	20-21
Piston Assembly .....	22-23
Lub.,Oil Pump and Governor Assembly .....	24-25
Cooling and Starting Assembly .....	26-27
Fuel Injection Pump Assembly .....	28-29
Air Cleaner Assembly .....	30-31
Muffler Assembly .....	32-33
Tools, Labels and Gasket Set Assembly .....	34-35
Accessories Assembly .....	36-37

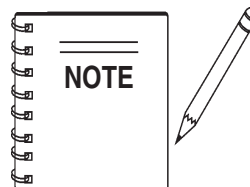

*Specification and part number are subject to change without notice.*

# MT-86D2 TAMPING RAMMER — EXPLANATION OF PARTS SECTION

The following section explains the different symbols and remarks used in the Parts section of this manual. Use the help numbers found on the back page of the manual if there are any questions.

The contents and part numbers listed in the parts section are subject to change **without notice**. Multiquip does not guarantee the availability of the parts listed.

Sample Parts List:

NO.	PART NO.	PART NAME	QTY.	REMARKS
1	12345	BOLT .....	1 ....	INCLUDES ITEMS W/*
2*		WASHER, 1/4 IN. ....		NOT SOLD SEPARATELY
2*	12347	WASHER, 3/8 IN. ....	1 ....	MQ-45T ONLY
3	12348	HOSE .....	A/R ..	MAKE LOCALLY
4	12349	BEARING .....	1 ....	S/N 2345B AND ABOVE

## NO. Column

**Unique Symbols** - All items with same unique symbol (\*, #, +, %, or >) in the number column belong to the same assembly or kit, which is indicated by a note in the “Remarks” column.

**Duplicate Item Numbers** - Duplicate numbers indicate multiple part numbers are in effect for the same general item, such as different size saw blade guards in use or a part that has been updated on newer versions of the same machine.

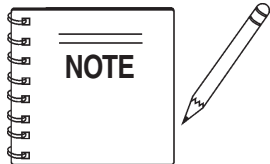

When ordering a part that has more than one item number listed, check the remarks column for help in determining the proper part to order.

## PART NO. Column

**Numbers Used** - Part numbers can be indicated by a number, a blank entry, or TBD.

TBD (To Be Determined) is generally used to show a part that has not been assigned a formal part number at time of publication.

A blank entry generally indicates that the item is not sold separately or is not sold by Multiquip. Other entries will be clarified in the “Remarks” Column.

## QTY. Column

**Numbers Used** - Item quantity can be indicated by a number, a blank entry, or A/R.

A/R (As Required) is generally used for hoses or other parts that are sold in bulk and cut to length.

A blank entry generally indicates that the item is not sold separately. Other entries will be clarified in the “Remarks” Column.

## REMARKS Column

Some of the most common notes found in the “Remarks” Column are listed below. Other additional notes needed to describe the item can also be shown.

**Assembly/Kit** - All items on the parts list with the same unique symbol will be included when this item is purchased.

Indicated by:  
“INCLUDES ITEMS W/(unique symbol)”

**Serial Number Break** - Used to list an effective serial number range where a particular part is used.

Indicated by:  
“S/N XXXXX AND BELOW”  
“S/N XXXX AND ABOVE”  
“S/N XXXX TO S/N XXX”

**Specific Model Number Use** - Indicates that the part is used only with the specific model number or model number variant listed. It can also be used to show a part is NOT used on a specific model or model number variant.

Indicated by:  
“XXXXX ONLY”  
“NOT USED ON XXXX”

**“Make/Obtain Locally”** - Indicates that the part can be purchased at any hardware shop or made out of available items. Examples include battery cables, shims, and certain washers and nuts.

**“Not Sold Separately”** - Indicates that an item cannot be purchased as a separate item and is either part of an assembly/kit that can be purchased, or is not available for sale through Multiquip.

# MT-86D2 TAMPING RAMMER — SUGGESTED SPARE PARTS

## **MT-86D2 RAMMER with Yanmar L48V6 Engine** **1-3 UNITS**

- 1 .... 956100057 ..... THROTTLE WIRE
- 3 .... 371010060 ..... ELEMENT ASSY
- 2 .... 954406010 ..... STRAINER, FUEL TANK
- 3 .... 18325455120 ..... STRAINER ASSY, FUEL
- 1 .... 0430430015 ..... CAP, FUEL TANK
- 2 .... 11425035110 ..... STRAINER, OIL LUB.
- 1 .... 16026076630 ..... ROPE, RECOIL STARTER

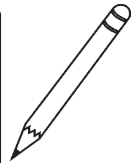
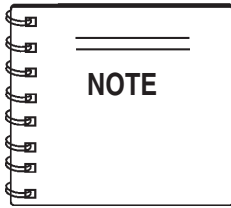

Part numbers on this Suggested Spare Parts List may supersede/replace the P/N shown in the text pages of this book.

# MT-86D2 TAMPING RAMMER — NAME PLATE AND DECALS

## NAME PLATE AND DECALS

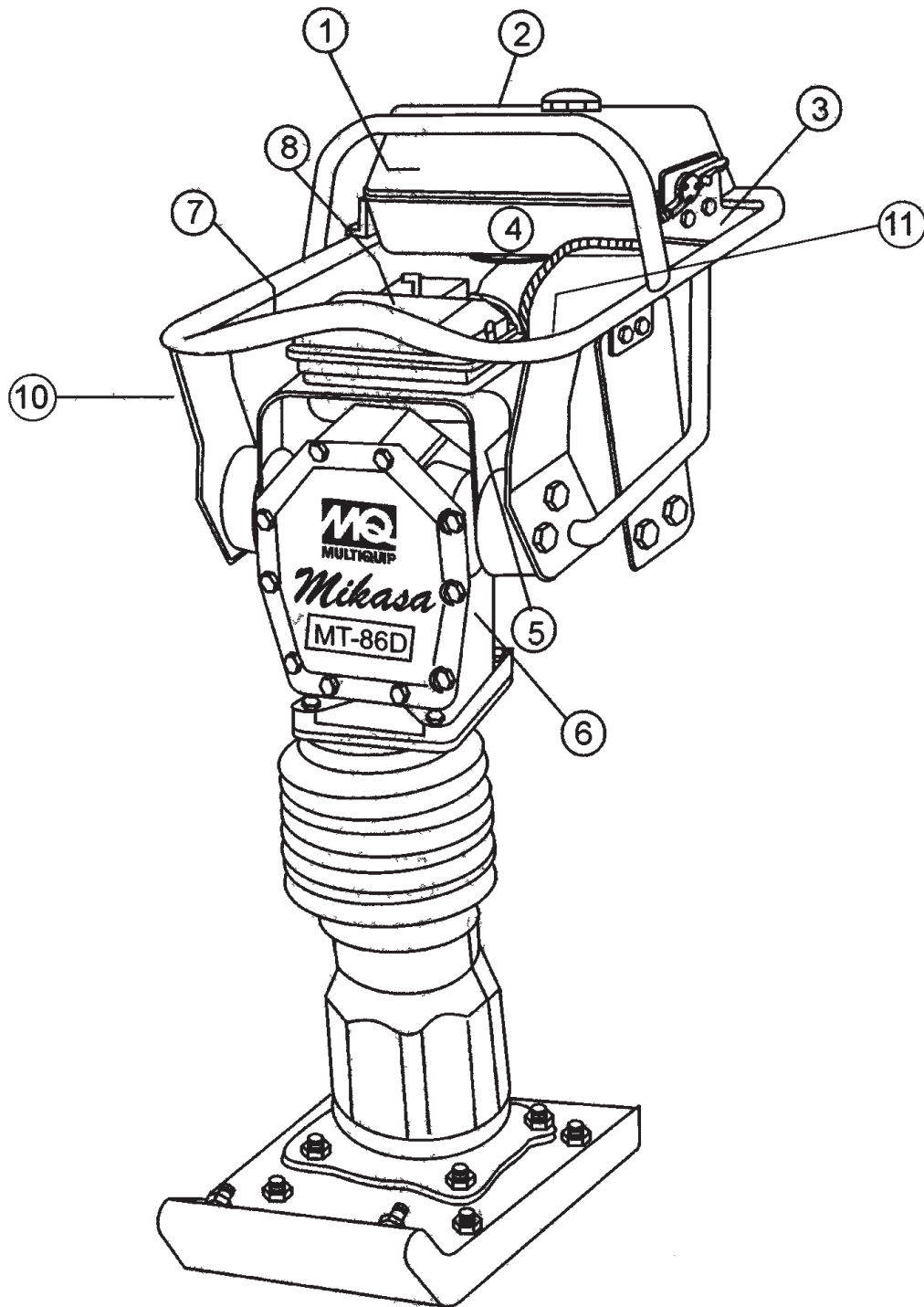

# MT-86D2 TAMPING RAMMER — NAMEPLATE AND DECALS

## NAME PLATE AND DECALS

<u>NO.</u>	<u>PART NO.</u>	<u>PART NAME</u>	<u>QTY.</u>	<u>REMARKS</u>
1*	920101580	DECAL: MIKASA MARK	1	
2*	920205840	DECAL: FUEL DIESEL .....	1 .....	NPA-584
3*	920203330	DECAL: EAR PROTECTION .....	1 .....	NPA-333
4*	920205820	DECAL ENGINE R.P.M 3100-3300	1	
5*	920203290	DECAL: READ OWNER'S MANUAL .....	1 .....	NPA-329
6		NAMEPLATE .....	1 .....	CONTACT MQ PARTS DEPT.
7*	920201950	DECAL: MOTOR OIL	1	
8*	920205830	DECAL, AIR CLEANER .....	1 .....	NPA-583
9	DCL86D/76D	DECAL KIT, MT-86D/MT-76D .....	1 .....	INCLUDES ITEMS W/*
10	920209100	DECAL: CAUTION	1	
11	920109360	DECAL: DO NOT LAY DOWN	1	

# MT-86D2 TAMPING RAMMER — CRANKCASE AND ENGINE ASSY.

## CRANKCASE AND ENGINE ASSY.

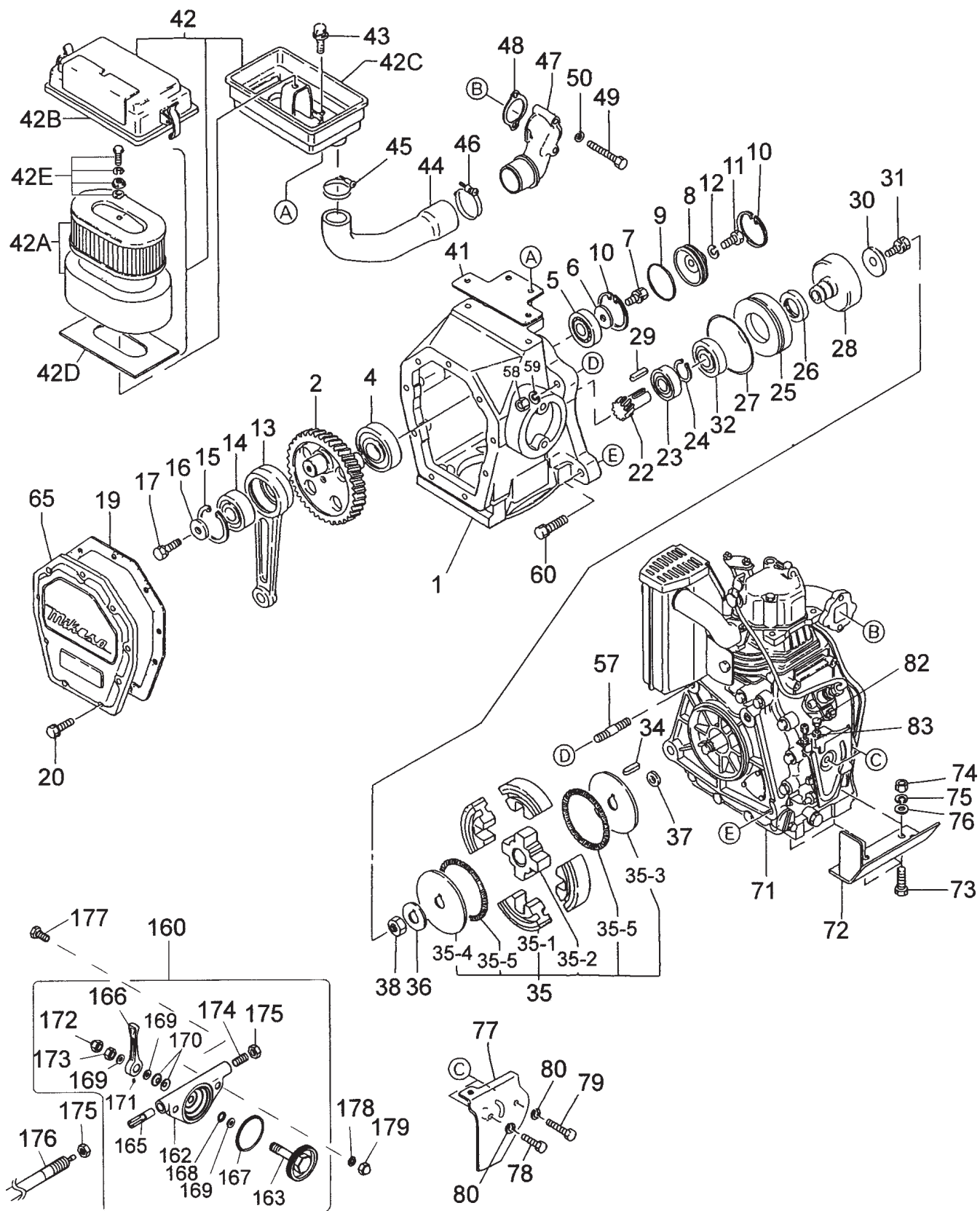

# MT-86D2 TAMPING RAMMER — CRANKCASE AND ENGINE ASSY.

## CRANKCASE AND ENGINE ASSY.

<u>NO.</u>	<u>PART NO.</u>	<u>PART NAME</u>	<u>QTY.</u>	<u>REMARKS</u>
1	372113340	CRANKCASE	1	
2	372335090	CRANK GEAR	1	
4	040006307	BEARING 6307	1	
5	040006205	BEARING 6205	1	
6	952400690	WASHER 9 X 35 X 4.5	1	
7	002219825	BOLT 8X25H, SW .....	1	REPLACES 002210825
8	372447660	BEARING COVER	1	
9	050300500	O-RING S-50	1	
10	080100600	STOP RING R-60	2	
11	001210610	BOLT 6X10H	1	
12	031106100	WASHER M6	1	
13	301300530	CONNECTING ROD	1	
14	040006305	BEARING 6305	1	
15	080100620	STOP RING R-62	1	
16	952400690	WASHER 9304	1	
17	002210825	BOLT 8X25H, SW .....	1	REPLACES 002210825
19	372447670	PACKING, FRONT COVER	1	
20	002200620	BOLT 6X20H, SW	9	
22	372447680	PINION	1	
23	040006205	BEARING 6205	1	
24	080200350	STOP RING S-35	1	
25	371449600	SPACER .....	1	REPLACES 371335280
26	060404010	OIL SEAL TC-40528	1	
27	050101000	O-RING G-100	1	
28	371447640	CLUTCH DRUM	1	
29	952405610	KEY 5X5X19R	1	
30	952405490	LOCK WASHER	1	
31	002210820	BOLT 8X20H, SW	1	
32	041006007	BEARING 6007Z	1	
34	22512040120	KEY 4X12	1	
35	371447632	CLUTCH ASSY. ....	1	INCLS. ALL ITEMS W/*
35-1*	943020060	CLUTCH SHOE (4)	1	
35-2*	943050050	CLUTCH BOSS	1	
35-3*	943060100	CLUTCH GUIDE (A)	1	
35-4*	943060020	CLUTCH GUIDE (B)	1	
35-5*	943030021	CLUTCH SPRING	2	
36	301010210	LOCK WASHER, CLUTCH	1	
37	371448260	SPACER 15X24X4	1	
38	022910170	NUT M12	1	
41	371448220	PACKING, AIR CLEANER	1	
42	371213392	AIR CLEANER ASSY .....	1	INCLUDES ITEMS W/# REPLACES 371213390
42A#	371010060	ELEMENT ASSY	1	
42B#	371010030	BODY ASSY	1	
42C#	371010042	BACK PLATE	1	
42D#	371010050	SEAT, AIR CLEANER	1	
42E#	371010070	BOLT ASSY.	1	



# MT-86D2 TAMPING RAMMER — CRANKCASE AND ENGINE ASSY.

## CRANKCASE AND ENGINE ASSY.

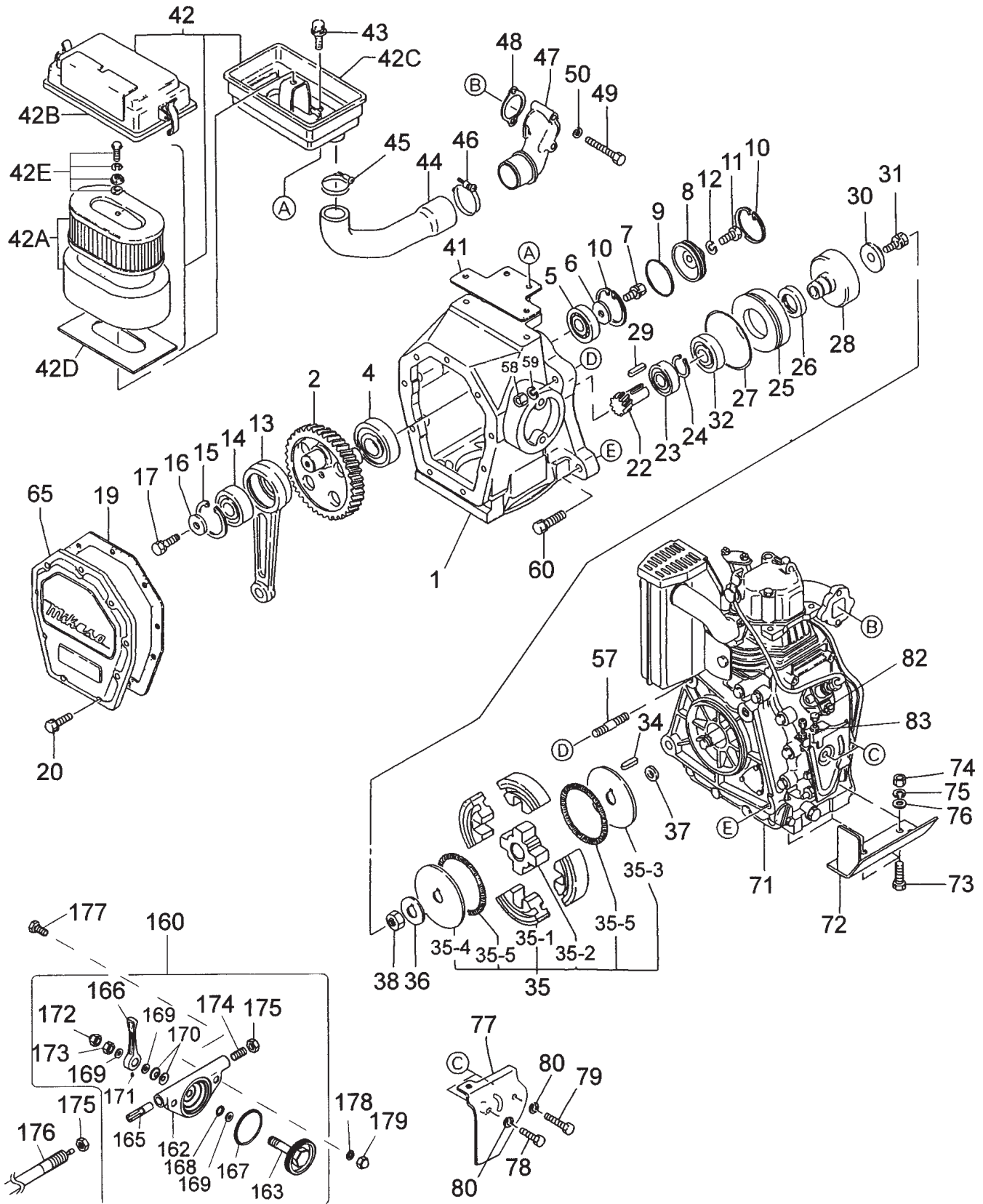

# MT-86D2 TAMPING RAMMER — CRANKCASE AND ENGINE ASSY.

## CRANKCASE AND ENGINE ASSY.

<u>NO.</u>	<u>PART NO.</u>	<u>PART NAME</u>	<u>QTY.</u>	<u>REMARKS</u>
43	002200820	BOLT 8X20H, SW	4	
44	371335110	INTAKE PIPE	1	
45	371000010	HOSE BAND (B)	1	
46	371000020	HOSE BAND (B)	1	
47	371335270	INTAKE FLANGE	1	
48	11428412200	GASKET, AIR INTAKE	1	
49	001200652	BOLT 6X60	2	
50	030206150	WASHER SW M6	2	
57	26226100452	STUD M10X20 PLATED	2	
58	020310080	NUT M10	2	
59	030210250	WASHER SW M10	2	
60	002211050	BOLT 10X50H, SW	2	
65	372213560	FRONT COVER MQ	1	
71	914410025	ENGINE ASSY L48V6	1	
72	371335100	UNDER PROTECTOR	1	
73	001211040	BOLT 10X40 H	2	
74	020310080	NUT M10	2	
75	030210250	WASHER, LOCK M10	2	
76	031110160	WASHER, FLAT M10	1	
77	371448021	LINK PROTECTOR	1	
78	001200630	BOLT 6X30	1	
79	001200635	BOLT 6X35	1	
80	030206150	WASHER SW M6	2	
81	16026078700	CLAMP WIRE	2	
82	11425066440	BOLT, ADJUSTING	2	
83	26756060002	LOCK NUT M6 PLATED	2	
160	362910060	THROTTLE LEVER ASSY	1	
162	362341550	THROTTLE BODY	1	
163	362910090	THROTTLE GEAR CP W/ BOLT	1	
165	362455620	SLIDER	1	
166	362455630	THROTTLE LEVER	1	
167	050100450	O-RING G-45	1	
168	050200100	O-RING P-10	1	
169	031110160	WASHER, FLAT M10	3	
170	032110180	CONICAL SPRING WASHER M10	2	
171	096206006	SOCKET HEAD SCREW 6X6	1	
172	022131008	CAP NUT M10	1	
173	020410060	NUT M10 ,H=6	1	
174	096208020	SOCKET HEAD SCREW 8X20	1	
175	020408050	NUT M8, H=5	2	
176	956100057	THROTTLE WIRE V390-510	1	
177	001220620	BOLT 6X20 T	2	
178	030206150	WASHER, LOCK M6	2	
179	022130605	CAP NUT M6	2	

# MT-86D2 TAMPING RAMMER — CYLINDER GUIDE AND FOOT ASSY.

CYLINDER GUIDE AND FOOT ASSY.

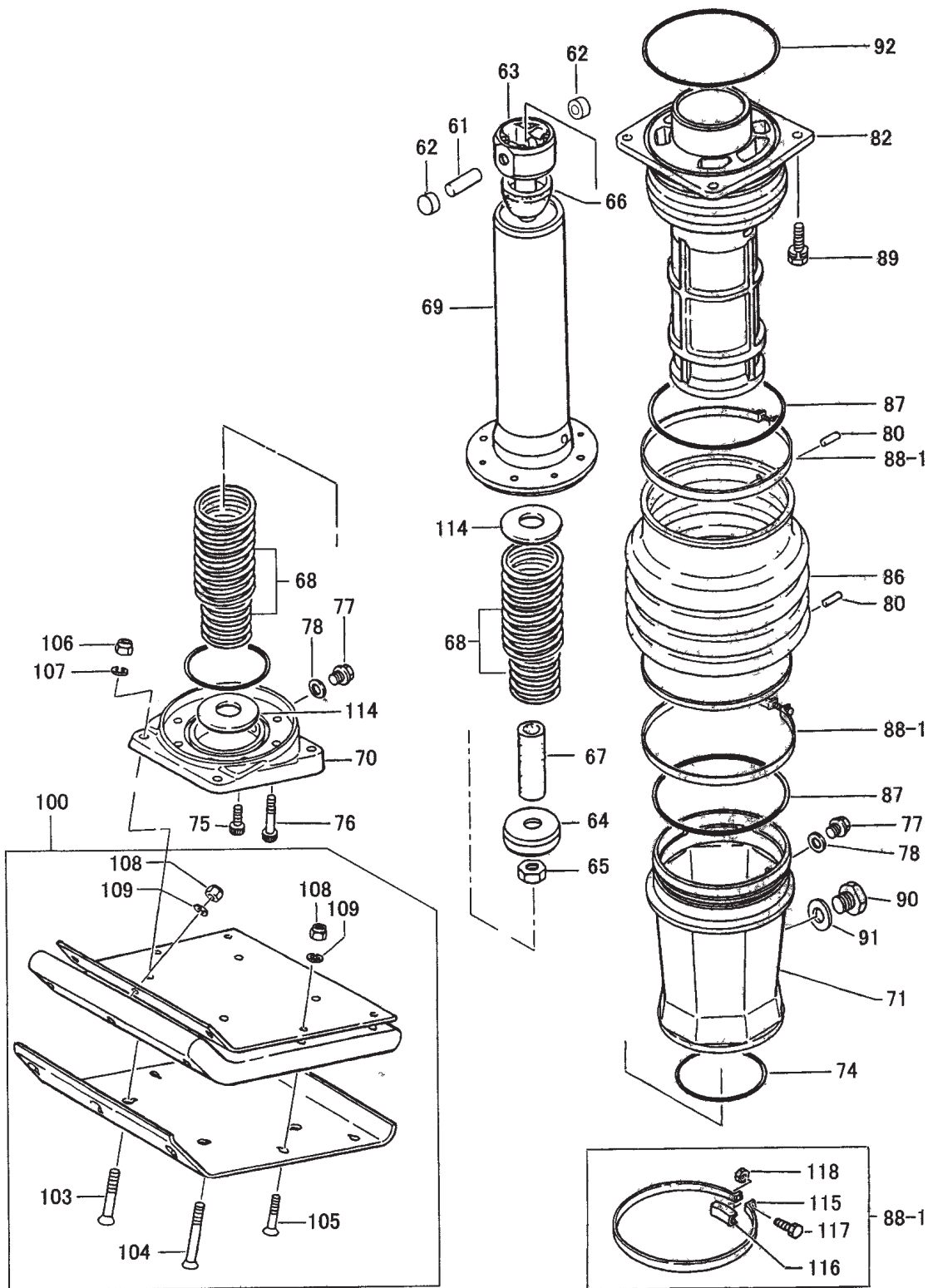

# MT-86D2 TAMPING RAMMER — CYLINDER GUIDE AND FOOT ASSY.

## CYLINDER GUIDE AND FOOT ASSY.

<u>NO.</u>	<u>PART NO.</u>	<u>PART NAME</u>	<u>QTY.</u>	<u>REMARKS</u>
61	652423290	PISTON PIN .....	1	REPLACES 352423290
62	363457870	PISTON PIN PLUG	2	
63	352210380	PISTON ROD	1	
64	372447700	PISTON END	1	
65	020118150	NUT M18, P1.5	1	
66	352431430	STOPPER,UPPER	1	
67	352437470	STOPPER,LOWER	1	
68	372335260	MAIN SPRING	2	
69	372213180	SPRING CYLINDER	1	
70	372213570	FOOT PLATE	1	
71	352110042	PROTECTION SLEEVE .....	1	REPLACES 352110040
73	050100950	O-RING G-95	1	
74	050101100	O-RING G-110	1	
75	014210020	SOCKET HEAD BOLT 10X20 T .....	4	REPLACES 001521020
76	014210035	SOCKET HEAD BOLT 10X35 T .....	4	REPLACES 001521035
77	953405270	PLUG 1/4X14 13L	2	
78	953405260	PACKING 1/4(CU)	2	
80	354446170	PIN 6D-8.5L	2	
82	354212490	GUIDE CYLINDER(L)	1	
86	354010010	BELLOWS,ORANGE	1	REPLACES 354332780
87	050931500	O-RING JAS03150	2	
88-1	354910020	BELLOWS CLAMP CP .....	2	INCLS. ALL ITEMS W/*
89	012710035	BOLT 10X35 H,SW .....	4	REPLACES 002211035
90	959010150	LEVEL GAUGE,PLUG TYPE	1	
91	953404670	COPPER PACKING 17X25.5X1	1	
92	050201500	O-RING P-150	1	
100	352910081	FOOT ASSY 330W-W/FCOVER .....	1	INCLS. ALL ITEMS W/#
103#	001611255	SUNK HEAD BOLT 12X75 H	4	
104#	001611259	SUNK HEAD BOLT 12X95 H .....	2	REPLACES 001611260
105#	015110055	SUNK HEAD BOLT 10X55 H .....	7	REPLACES 001611051
106	021112140	NYLON NUT M12 .....	4	REPLACES 022711214
107	030212300	WASHER, LOCK M12	4	
108#	021110120	NYLON NUT M10 .....	7	REPLACES 022711012
109#	030210250	WASHER, LOCK M10	7	
114	352441730	SPRING SEAT 80D-1.6T	1	
115*	354336352	BELLOWS CLAMP (1.6T) 171D .....	2	REPLACES 354329380
116*	354442340	BAND GUIDE,BELLOWS	2	
117*	001220840	BOLT 8X40T	2	
118*	020108060	NUT M8 .....	2	REPLACES 020308060

# MT-86D2 TAMPING RAMMER — TANK AND HANDLE ASSY.

TANK AND HANDLE ASSY.

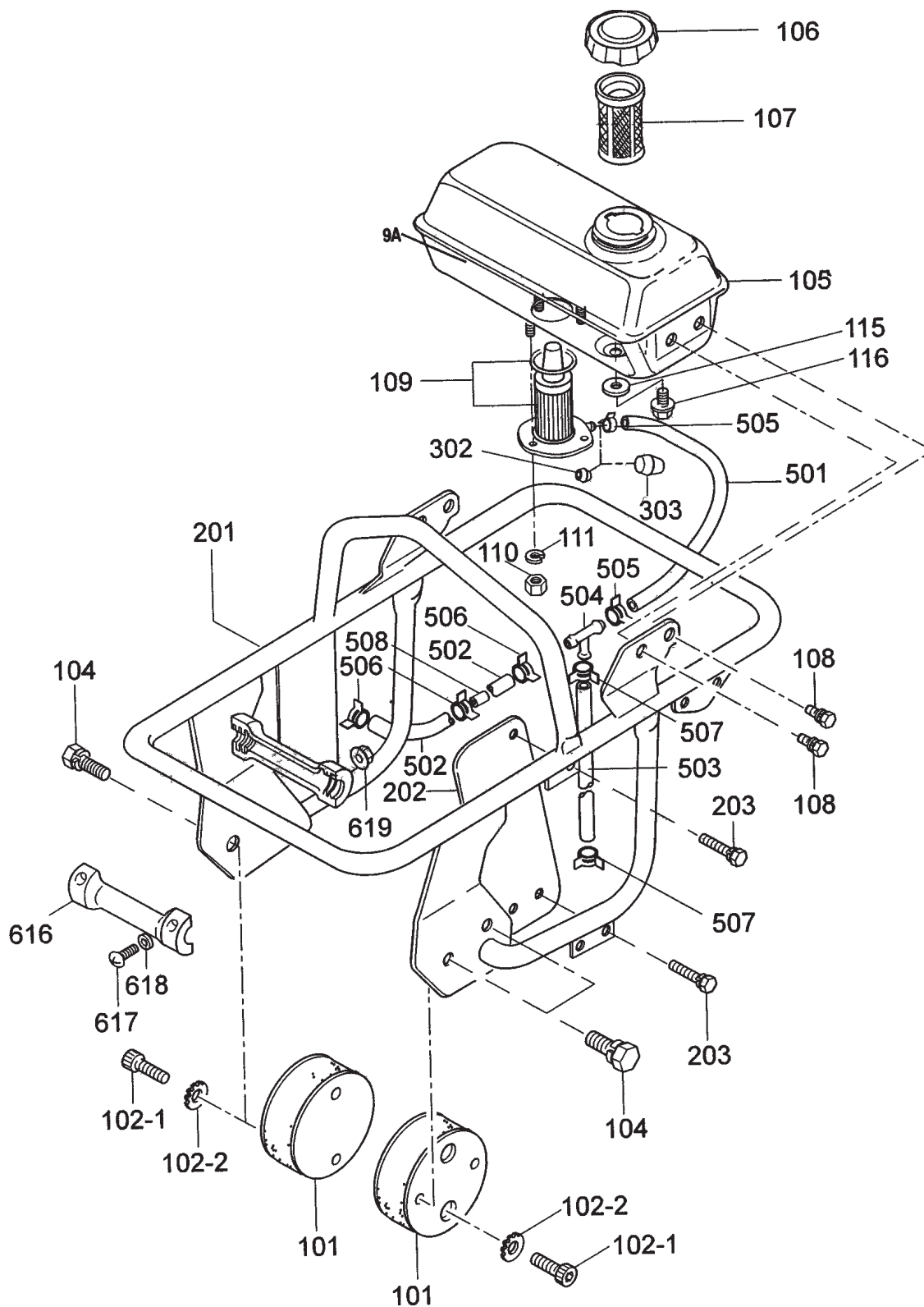

# MT-86D2 TAMPING RAMMER — TANK AND HANDLE ASSY.

## TANK AND HANDLE ASSY.

<u>NO.</u>	<u>PART NO.</u>	<u>PART NAME</u>	<u>QTY.</u>	<u>REMARKS</u>
101	351319900	SHOCK ABSORBER	2	
102-1	014210020	SOCKET HEAD BOLT 10X20T .....	4	REPLACES 001521020
102-2	033121009	TOOTHED LOCK WASHER B M10	4	
104	012210020	BOLT 10X20H, SW .....	4	REPLACES 002211020
105	371118200	FUEL TANK	1	
106	0430430015	FUEL TANK CAP .....	1	REPLACES 953404650
107	954406010	STRAINER (#110)	1	
108	011808015	BOLT 8X15H, SW, PW .....	4	REPLACES 002410815
109	18325455120	STRAINER ASSY, FUEL	1	
110	020106050	NUT M6 .....	3	REPLACES 020306050
111	030206150	WASHER, LOCK M6	3	
115	953405750	PACKING 10.5D-17D-2T	1	
116	953405800	FLANGE PLUG PF1/8	1	
201	371118190	HANDLE	1	
202	371448010	SIDE PROTECTOR	1	
203	011808015	BOLT 8X15H, SW, PW .....	3	REPLACES 002410815
302	953406200	PROTECTION CAP	1	
303	953405740	PLASTIC CAP VC12	1	
501	18366659330	PIPE, FUEL DRAIN	1	
502	18325059050	PIPE, FUEL OIL	1	
503	11465459070	PIPE, FUEL RETURN	1	
504	11428459710	JOINT	1	
505	12476659050	CLAMP 11.5	2	
506	10699044660	BAND HOSE 12.5	3	
507	12472259050	CLAMP 9	2	
508	18325059040	PIECE	1	
616	955200052	ROLLER, W/ PIN	2	
616	955200053	ROLLER, W/ PIN	2	
617	091005025	SCREW 5X25	4	
618	031105080	WASHER, FLAT M5	4	
619	022610505	FLANGE NUT M5 H	4	

# YANMAR L-48V6 ENGINE — CYLINDER BLOCK ASSY.

## CYLINDER BLOCK ASSY.

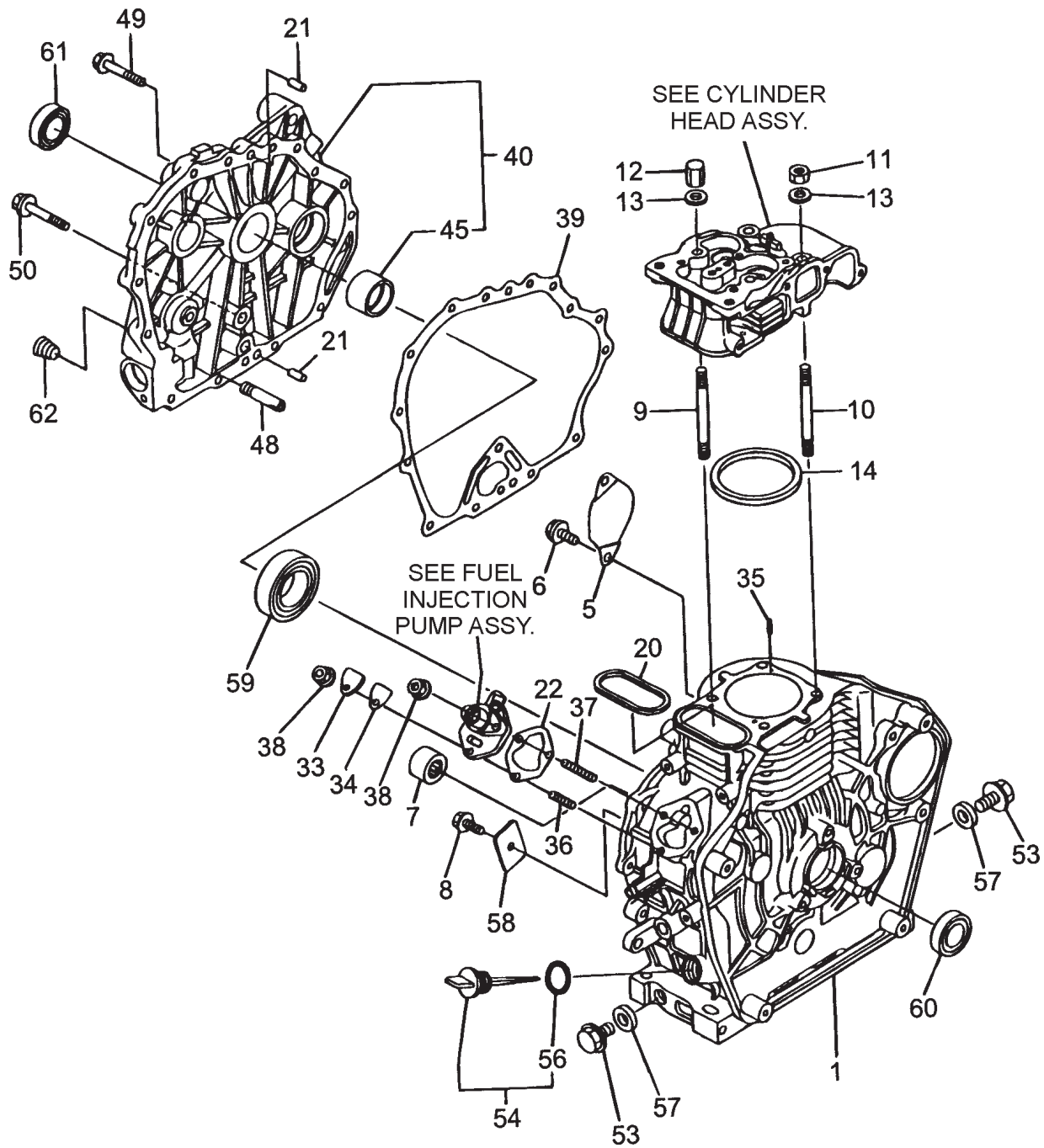



# YANMAR L-48V6 ENGINE — CYLINDER BLOCK ASSY.

## CYLINDER BLOCK ASSY.

<u>NO.</u>	<u>PART NO.</u>	<u>PART NAME</u>	<u>QTY.</u>	<u>REMARKS</u>
1	11429501050	CYLINDER BLOCK ASSY.	1	
5	11439901700	STARTER COVER	1	
6	26106100122	BOLT M10X 12 PLATED	2	
7	24162152112	NEEDLE BEARING	1	
8	26106080122	BOLT M 8X 12 PLATED	1	
9	11429901200	CYLINDER HEAD BOLT A	2	
10	11429901210	CYLINDER HEAD BOLT B	2	
11	11429901220	CYLINDER HEAD NUT A	2	
12	11429901230	CYLINDER HEAD NUT B	2	
13	12495001250	WASHER	4	
14	11429501330	CYLINDER HEAD GASKET ASSY.	1	
20	11429901380	O- RING	1	
21	11429901600	PIN 8X12	2	
22	11429901800	SHIM SET	1	
33	11429901830	COVER, (FO PUMP)	1	
34	11425001841	GASKET	1	
35	22312040080	PIN 4X8 STRAIGHT	2	
36	26226060182	STUD M 6X 18 PLATED	1	
37	26226060222	STUD M 6X 22 PLATED	2	
38	26366060002	NUT M 6	3	
39	11429901410	CRANK CASE GASKET	1	
40	11428401452	DRUM CASE COVER .....	1	INCLUDES ITEMS W/*
45*	11425002100	MAIN BEARING US=STD.	1	
45*	11425002200	BEARING US=0.25, MAIN	1	
45*	11425002210	BEARING US=0.50, MAIN	1	
48	11429935150	L.O. INLET PIPE	1	
49	26106060252	BOLT M 6X 25 PLATED	14	
50	26106080352	BOLT M 8X 35 PLATED	1	
53	11429901690	PLUG M16	2	
54	11429901760	CAP, W/LUBE OIL GAUGE .....	1	INCLUDES ITEMS W/#
56#	11429901950	O- RING	1	
57	22190160002	SEAL WASHER 16S	2	
58	11429902030	RETAINER	1	
59	11425002113	BALL BEARING	1	
60	11429902220	OIL SEAL	1	
61	16021002220	OIL SEAL	1	
62	23876010000	PLUG PT 1/8, SCREW	1	



# YANMAR L-48V6 ENGINE — CYLINDER HEAD ASSY.

CYLINDER HEAD ASSY.

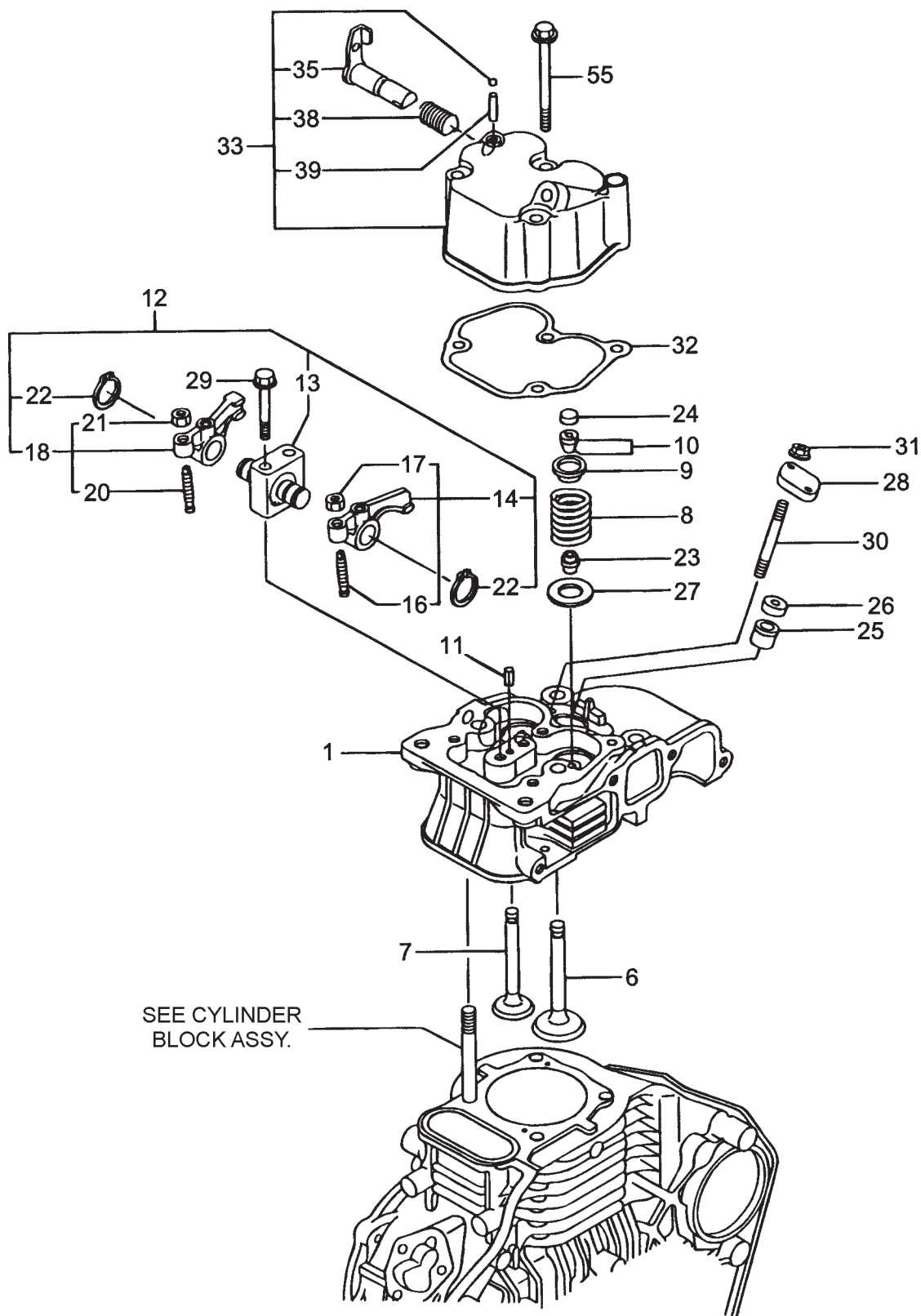

# YANMAR L-48V6 ENGINE — CYLINDER HEAD ASSY.

## CYLINDER HEAD ASSY.

<u>NO.</u>	<u>PART NO.</u>	<u>PART NAME</u>	<u>QTY.</u>	<u>REMARKS</u>
1	11477111020	CYLINDER HEAD	1	
6	11477111100	SUCTION VALVE	1	
7	11477111110	EXHAUST VALVE	1	
8	11429911120	VALVE SPRING	2	
9	1142511180	SPRING RETAINER	2	
10	27310055001	COTTER	2	
11	22351040008	SPRING PIN 4X8	1	
12	11477111250	ARM SUPPORT CAM .....	1	INCLUDES ITEMS W/*
13*	11477111260	ROCKER ARM SUPPORT	1	
14*	11477111650	INTAKE ARM ASSY.	1	
16	11425011240	VALVE ADJUST. SCREW	1	
17	26856060002	LOCK NUT 6	1	
18*	11477111660	EXHAUST ARM ASSY.	1	
20	11425011240	VALVE ADJUST. SCREW	1	
21	26856060002	LOCK NUT 6	1	
22*	22242000120	CIR CLIP 12	2	
23	11425011340	VALVE STEM SEAR	2	
24	11926011370	VALVE CAP	2	
25	11477111461	NOZZLE GASKET	1	
26	11429511470	NOZZLE SPACER	1	
27	11429911600	VALVE SPRING WASHER	2	
28	11429911901	NOZZLE RETAINER	1	
29	26106060452	BOLT M 6X45 PLATED	2	
30	11471811910	STUD BOLT M6X65	2	
31	26366060002	NUT M 6	2	
32	11477111310	BONNET GASKET	1	
33	11477111970	BONNET COMPLETE .....	1	INCLUDES ITEMS W/#
35#	11425003591	SHAFT ASSY. DECOMP.	1	
38#	11428803641	SPRING	1	
39#	11428803950	PIN	1	
55	26106060552	BOLT M 6X 55 PLATED	3	

# YANMAR L-48V6 ENGINE — CRANKSHAFT AND CAMSHAFT ASSY.

CRANKSHAFT AND CAMSHAFT ASSY.

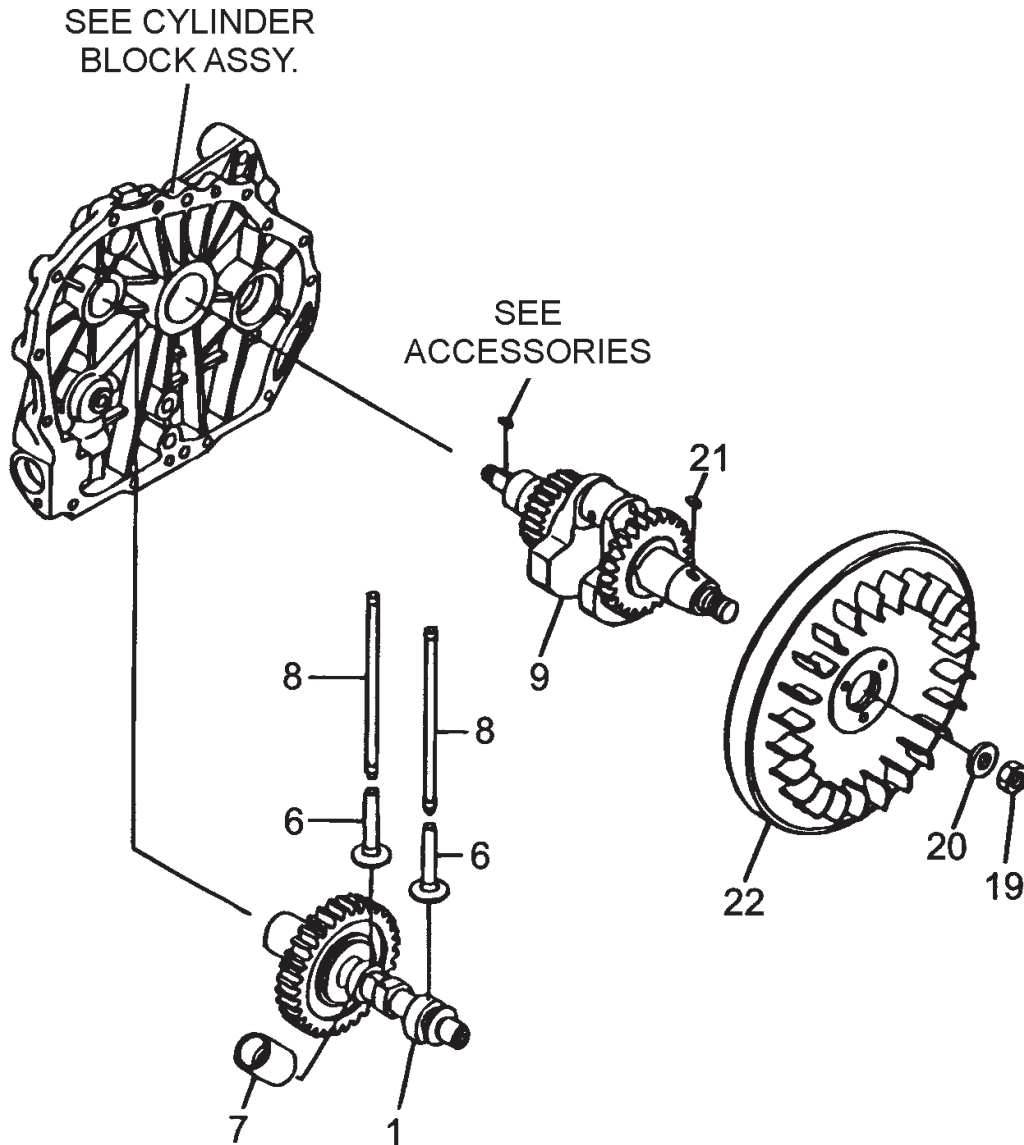

# YANMAR L-48V6 ENGINE — CRANKSHAFT AND CAMSHAFT ASSY.

## CRANKSHAFT AND CAMSHAFT ASSY.

<u>NO.</u>	<u>PART NO.</u>	<u>PART NAME</u>	<u>QTY.</u>	<u>REMARKS</u>
1	71429514580	CAMSHAFT (D) ASSY.	1	
6	11429914200	TAPPET	2	
7	11477114260	TAPPET, F.O.	1	
8	11425014451	PUSH ROD	2	
9	71478121740	CRANKSHAFT (EDRM) ASSY.	1	
19	11429921220	NUT	1	
20	11429921550	FLYWHEEL WASHER	1	
21	22512040120	KEY 4X 12	1	
22	11429921470	FLYWHEEL	1	

# YANMAR L-48V6 ENGINE — PISTON ASSY.

PISTON ASSY.

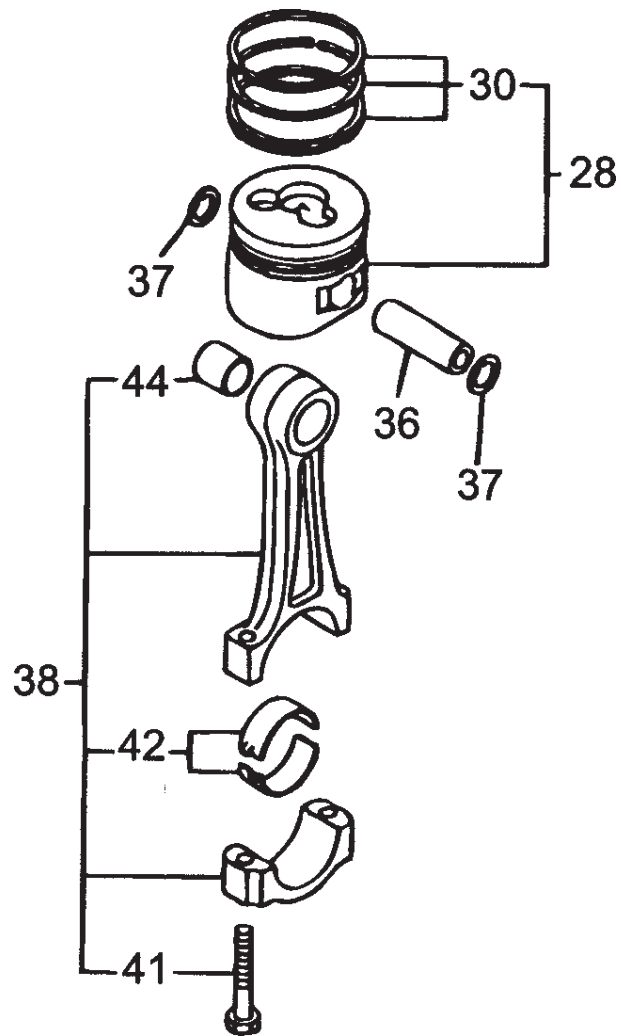

# YANMAR L-48V6 ENGINE — PISTON ASSY.

## PISTON ASSY.

<u>NO.</u>	<u>PART NO.</u>	<u>PART NAME</u>	<u>QTY.</u>	<u>REMARKS</u>
1	71429514580	CAMSHAFT (D) ASSY.	1	
6	11429914200	TAPPET	2	
7	11477114260	TAPPET, F.O.	1	
8	11425014451	PUSH ROD	2	
9	71478121740	CRANKSHAFT (EDRM) ASSY.	1	
19	11429921220	NUT	1	
20	11429921550	FLYWHEEL WASHER	1	
21	22512040120	KEY 4X 12	1	
22	11429921470	FLYWHEEL	1	
28	71429522720	PISTON W/RINGS (D) STD. ....	1	INCLUDES ITEMS W/#
28	71429522620	PISTON W/RING OS=0.25 .....	1	INCLUDES ITEMS W/#
28	71429522580	PISTON W/RING OS=0.50 .....	1	INCLUDES ITEMS W/#
30#	71429522500	PISTON RING SET STD.	1	
30#	71429522540	PISTON RING SET OS=0.25	1	
30#	71429522550	PISTON RING SET OS=0.50	1	
36	11429922300	PISTON PIN	1	
37	22252000190	CIRCLIP 19	2	
38	71429923700	CONNECTING ROD ASSY. ....	1	INCLUDES ITEMS W/*
41*	11926523200	ROD BOLT	2	
42*	71477023600	CRANKPIN BEARING U.S=STD.	1	
42*	71477023610	CRANKPIN BEARING U.S=0.25	1	
42*	71477023620	CRANKPIN BEARING U.S=0.50	1	
44*	11477023100	PISTON PIN BUSH	1	

# YANMAR L-48V6 ENGINE — LUB. OIL PUMP AND GOVERNOR ASSY.

## LUB. OIL PUMP AND GOVERNOR ASSY.

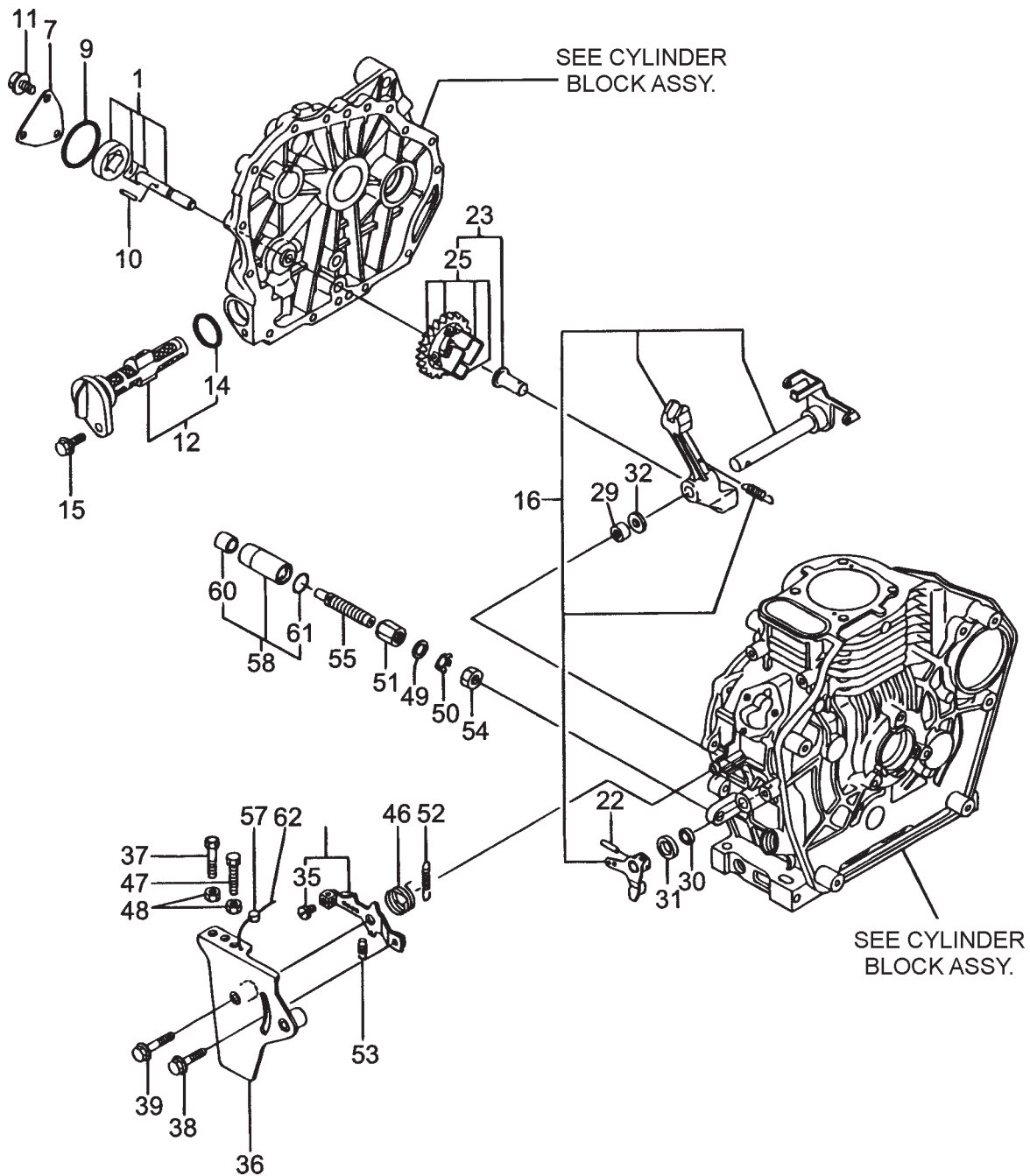

# YANMAR L-48V6 ENGINE — LUB. OIL PUMP AND GOVERNOR ASSY.

## LUB. OIL PUMP & GOVERNOR ASSY.

<u>NO.</u>	<u>PART NO.</u>	<u>PART NAME</u>	<u>QTY.</u>	<u>REMARKS</u>
1	11425032010	LUB. OIL PUMP ASSY.	1	
7	11428432070	LUB. OIL PUMP COVER	1	
9	11429932570	O- RING COVER	1	
10	22312030160	PARALLEL PIN 3X16	1	
11	26106060122	BOLT M 6X 12 PLATED	3	
12	11429935110	LUB. OIL FILTER COMPLETE .....	1	INCLUDES ITEMS W/#
14#	24341000224	O- RING 1A S- 22.4	1	
15	26106060162	BOLT M 6X 16 PLATED	1	
16	11429561190	GOVERNOR LEVER ASSY.	1	
22	22322030200	TAPER PIN 3X20	1	
23	71477061100	GOVERNOR ASSY. ....	1	INCLUDES ITEMS W/*
25	11477061220	GOVERNOR WEIGHT ASSY.	1	
29	11477061520	NEEDLE BEARING	2	
30	11429961600	OIL SEAL	1	
31	11477061610	THRUST WASHER	1	
32	11429961190	GOVERNOR WASHER	1	
33	11477166050	REGULATOR HANDLE .....	1	INCLUDES ITEMS W/%
35%	26117040088	BOLT 4X 8	1	
36	11477266100	REGULATOR HANDLE BASE	1	
37	11429967080	ADJUSTING BOLT	1	
38	26106060302	BOLT M 6X 30 PLATED	1	
39	26106060352	BOLT M6X30 PLATED	1	
46	11429966440	RETURN SPRING	1	
47	11429966440	ADJUSTING BOLT	1	
48	26757060002	LOCK NUT M 6 PLATED	2	
49	11477161810	PLAIN WASHER 14	1	
50	11477161830	PLATE	1	
51	11429561940	NUT	1	
52	11429966010	REGULATOR SPRING	1	
53	11429966200	RETURN SPRING	1	
54	11477166690	NUT M14	1	
55	11477166600	FUEL LIMITER ASSY.	1	
57	13521061090	LEAD	1	
58	11477161890	PROTECTOR CMP .....	1	INCLUDES ITEMS W/+
60	11477161960	SPACER	1	
61+	24311000180	O- RING 1A P-18.0	1	
62+	22451060000	WIRE 0.6	1	



# YANMAR L-48V6 ENGINE — COOLING AND STARTING ASSY.

COOLING AND STARTING ASSY.

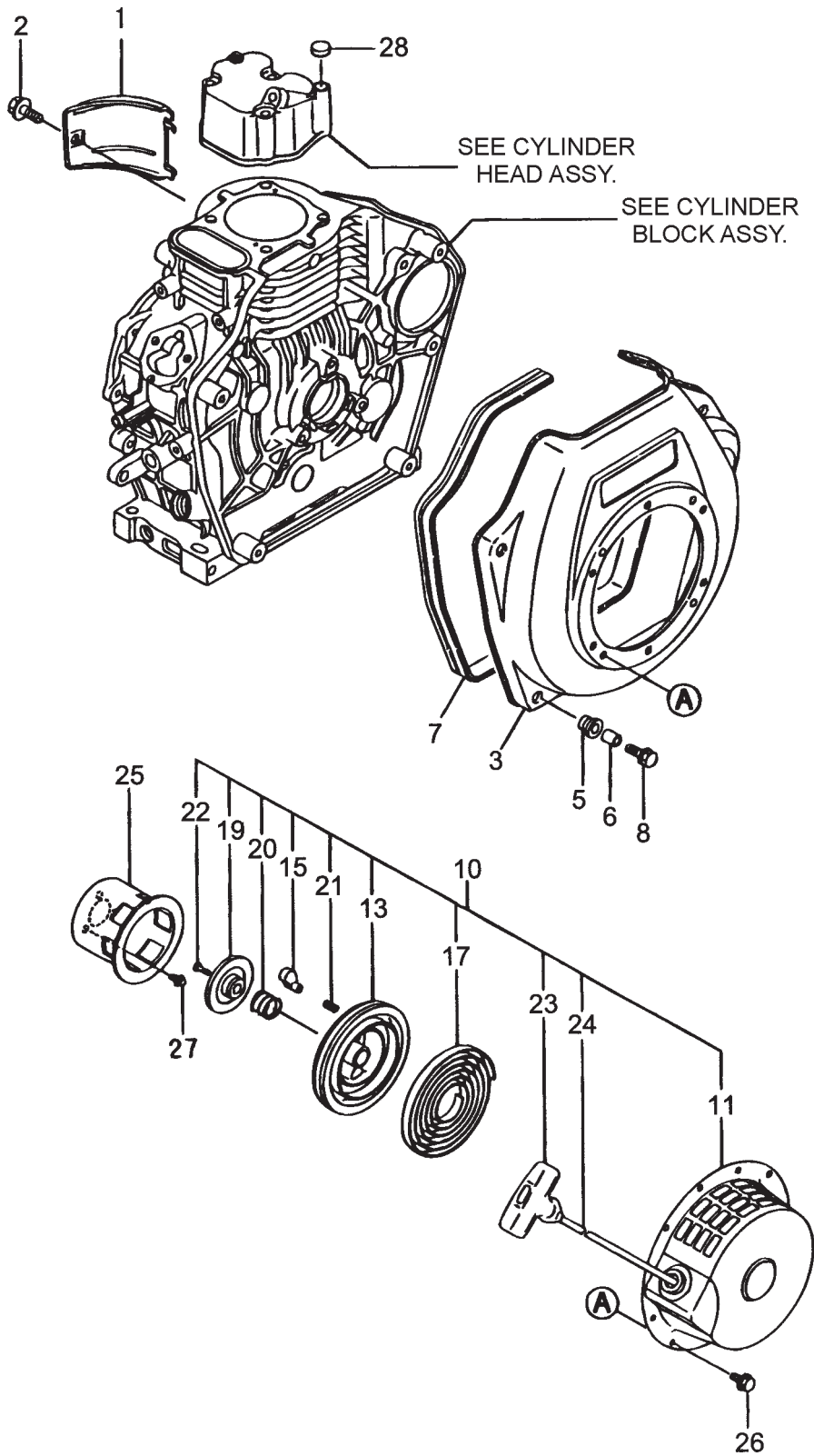

# YANMAR L-48V6 ENGINE — COOLING AND STARTING ASSY.

## COOLING & STARTING DEVICE ASSY.

<u>NO.</u>	<u>PART NO.</u>	<u>PART NAME</u>	<u>QTY.</u>	<u>REMARKS</u>
1	11429945210	CYLINDER COVER	1	
2	26106060122	BOLT M 6X12 PLATED	1	
3	11477145110	COOLING FAN CASE	1	
5	11429945300	CUSHION RUBBER	4	
6	11429945310	FAN CASE COLLAR	4	
7	11429945330	FAN CASE SEAL	1	
8	11429945350	FAN CASE BOLT	4	
10	11429976250	RECOIL STARTER (D) ASSY. ....	1	INCLUDES ITEMS W/*
11*	11429976500	STARTER CASE	1	
13*	11429976520	REEL	1	
15*	11439976550	RATCHET	1	
17*	11439976540	SPIRAL SPRING	1	
19*	11439975550	RATCHET COVER	1	
20*	11439976560	SPRING	1	
21*	11439976570	RETURN SPRING	1	
22*	11439976580	SCREW	1	
23*	11439976620	STARTER KNOB	1	
24*	11429976630	STARTER ROPE	1	
25	11429976590	STARTER PULLEY	1	
26	26106060082	BOLT M 6X 8 PLATED	4	
27	26106060122	BOLT M6X 12 PLATED	3	
28	12910061850	BORE PLUG 12	1	

# YANMAR L-48V6 ENGINE — FUEL INJECTION PUMP ASSY.

## FUEL INJECTION PUMP ASSY.

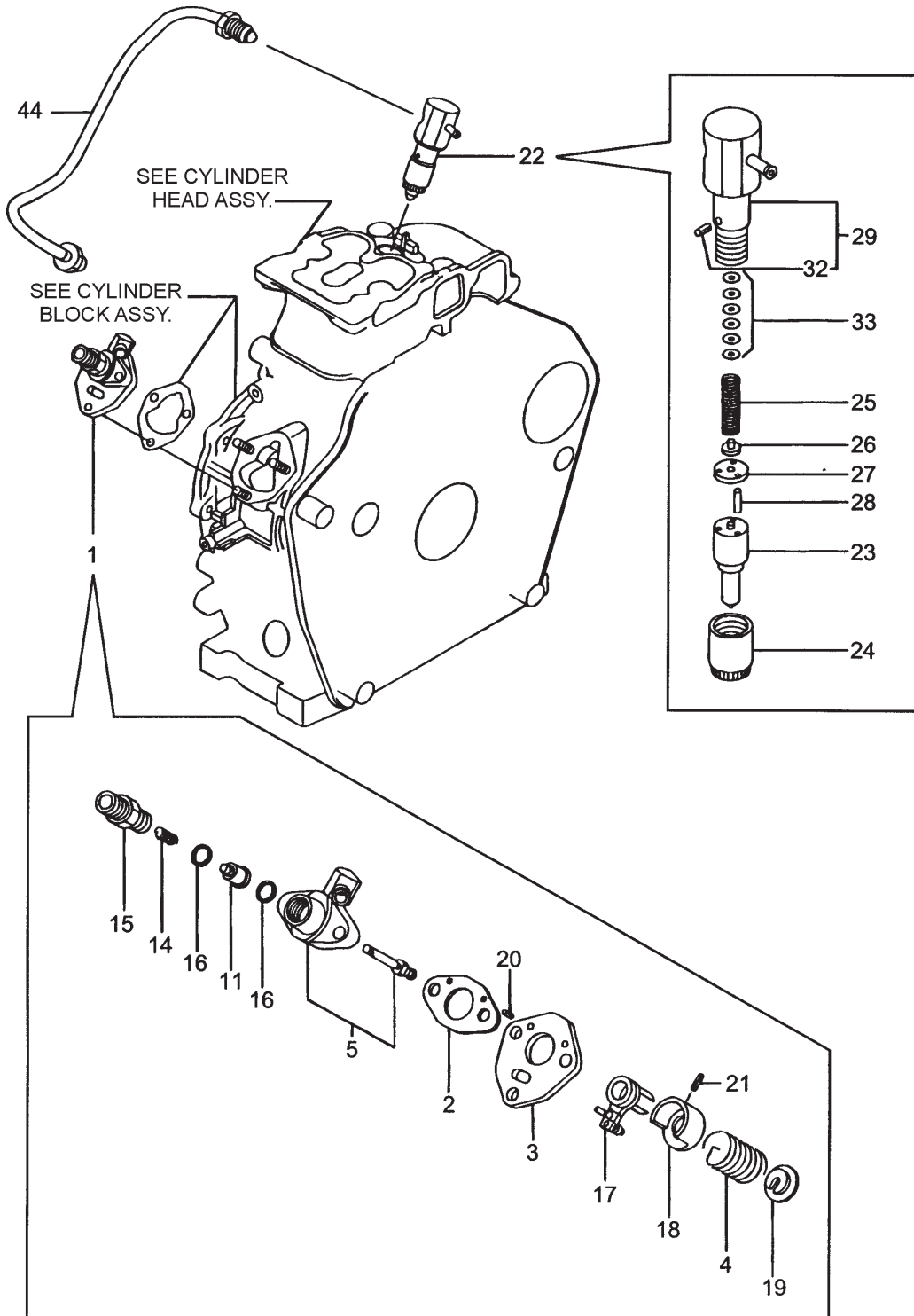

# YANMAR L-48V6 ENGINE — FUEL INJECTION PUMP ASSY.

## FUEL INJECTION PUMP ASSY.

<u>NO.</u>	<u>PART NO.</u>	<u>PART NAME</u>	<u>QTY.</u>	<u>REMARKS</u>
1	71477551100	INJECTION PUMP ASSY., F .....	1 .....	INCLUDES ITEMS W/*
2*	10554651020	GASKET	1	
3*	11425051080	PLATE	1	
4*	11425051160	SPRING	1	
5*	11435051200	FUEL INJECTION PUMP BODY	1	
11*	11425051300	VALVE ASSY. DELIVERY	1	
14*	10554651330	DELIVERY VALVE SPRING	1	
15*	11425051340	F.I.P. DELIVERY HOLDER	1	
16*	12455051350	DELIVERY GASKET	2	
17*	11425051600	CONTROL LEVER ASSY.	1	
18*	11425051640	SPRING SEAT ( A)	1	
19*	11425051650	SPRING SEAT (B)	1	
20*	22351020006	SPRING PIN 2X 6	2	
21*	22351030008	SPRING PIN 3X 8	1	
22	71477553101	FUEL INJECTION VALVE ASSY. ....	1 .....	INCLUDES ITEMS W/ #
23 #	11477153001	FUEL INJECTION NOZZLE ASSY.	1	
24 #	11959353080	NOZZLE CASE NUT	1	
25 #	11425053120	NOZZLE SPRING	1	
26 #	11959353130	SPRING RETAINER	1	
27 #	11477553140	VALVE STOP SPACER	1	
28 #	11477553210	PIN	2	
29 #	11477553100	HOLDER ASSY. ....	1 .....	INCLUDES ITEMS W/ %
32 #%	11477553330	PIN	1	
33 #	11425053400	SHIM PACK	1	
44	11477159803	FUEL INJECTION PIPE	1	

# YANMAR L-48V6 ENGINE — AIR CLEANER ASSY.

AIR CLEANER ASSY.

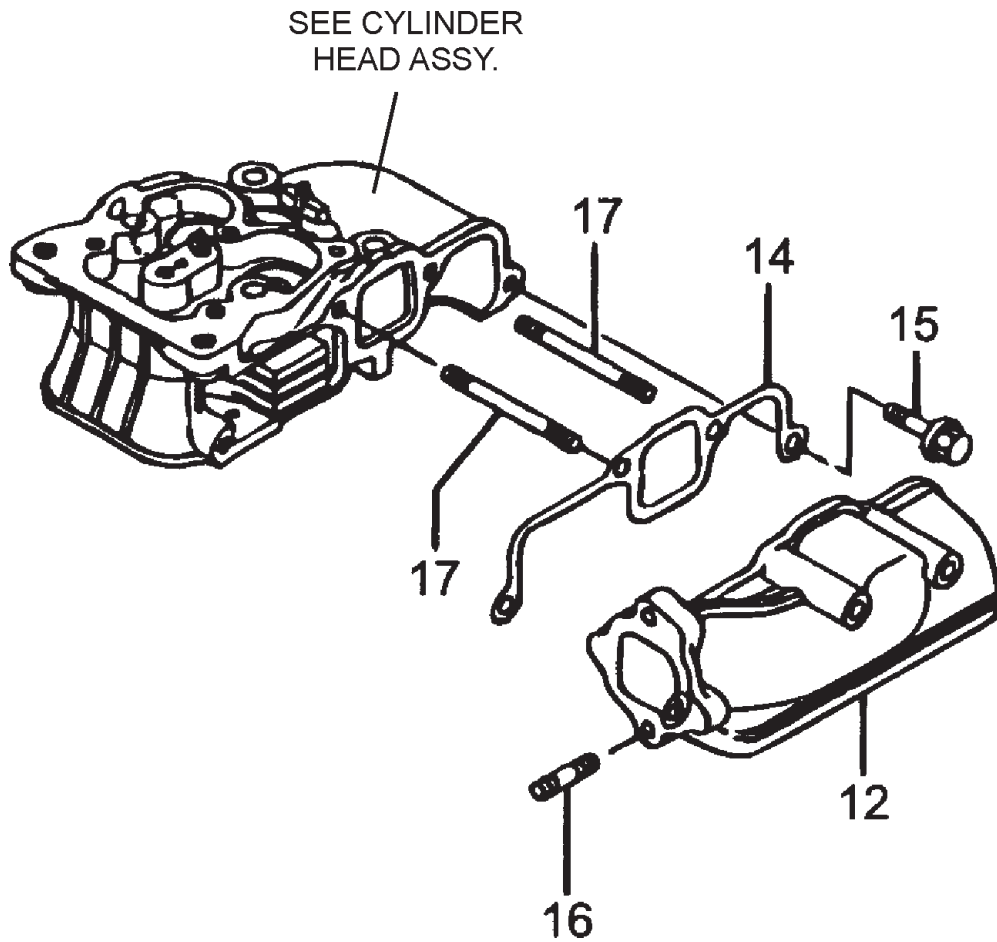

# YANMAR L-48V6 ENGINE — AIR CLEANER ASSY.

AIR CLEANER ASSY.

<u>NO.</u>	<u>PART NO.</u>	<u>PART NAME</u>	<u>QTY.</u>	<u>REMARKS</u>
12	1147212010	AIR INTAKE PIPE	1	
14	11477112200	AIR INTAKE GASKET	1	
15	26106060252	BOLT M 6X 25 PLATED	2	
16	26226060142	STUD M 6X14 PLATED	1	
17	26226060552	STUD M 6X 55	2	

# YANMAR L-48V6 ENGINE — MUFFLER ASSY.

MUFFLER ASSY.

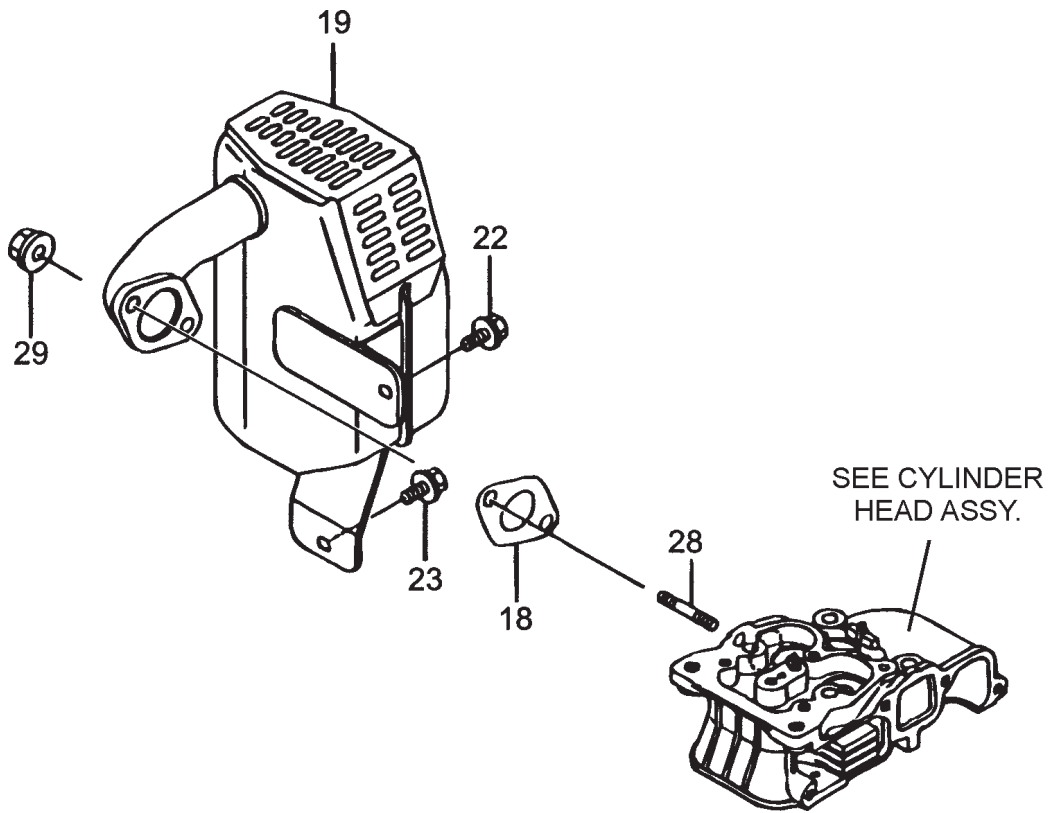

## YANMAR L-48V6 ENGINE — MUFFLER ASSY.

MUFFLER ASSY.

<u>NO.</u>	<u>PART NO.</u>	<u>PART NAME</u>	<u>QTY.</u>	<u>REMARKS</u>
18	11429913200	MUFFLER GASKET	1	
19	11428413500	MUFFLER ASSY., DRM	1	
22	26106060142	BOLT M 6X14 PLATED	1	
23	26106060182	BOLT M 6X18 PLATED	1	
28	26216080182	STUD M 8X 18 PLATED	2	
29	26366080002	NUT M 8	2	



# YANMAR L-48V6 ENGINE — TOOLS, LABELS AND GASKET SET ASSY.

TOOLS, LABELS AND GASKET SET ASSY.

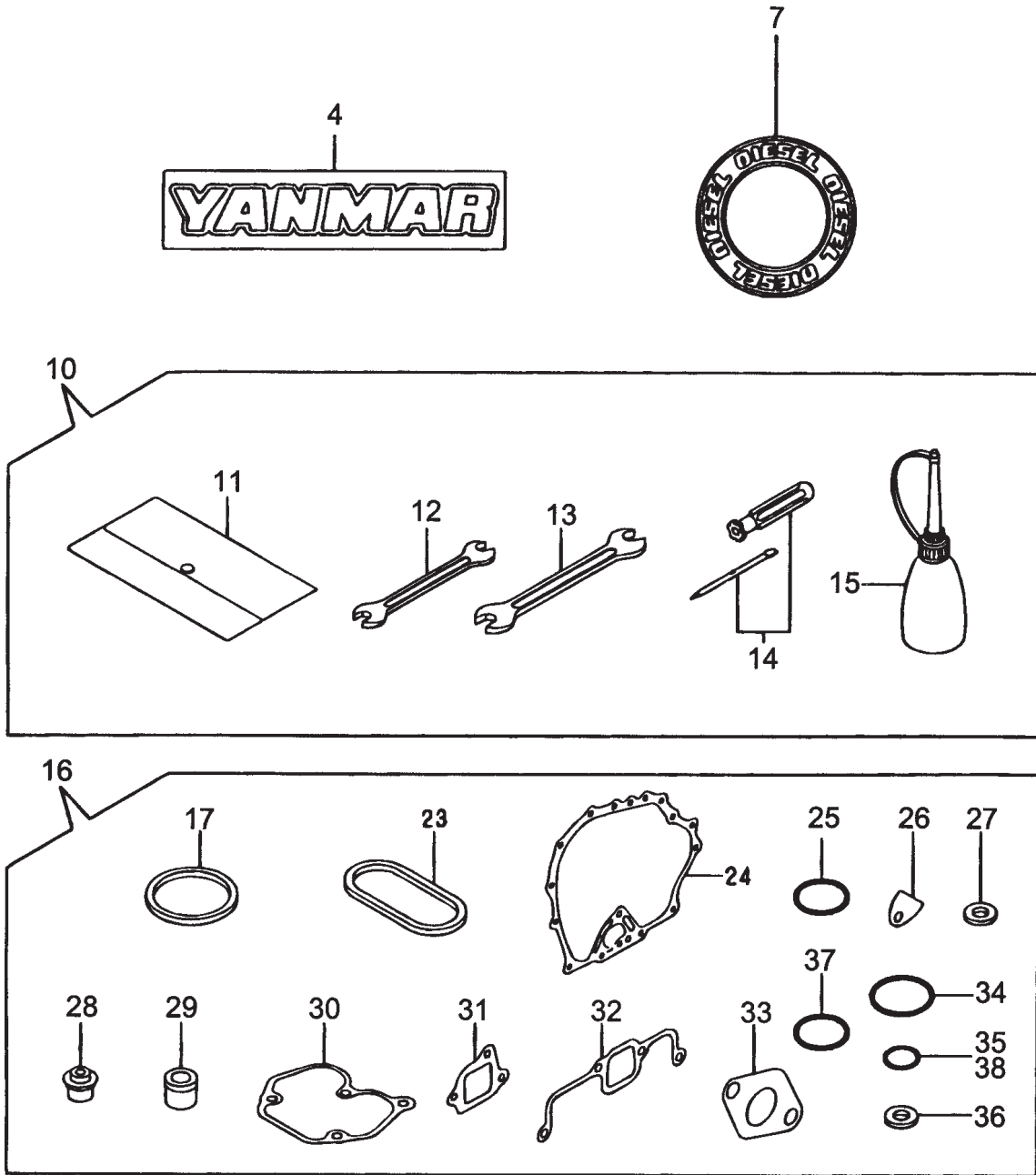

# YANMAR L-48V6 ENGINE — TOOLS, LABELS AND GASKET SET ASSY.

## TOOLS, LABELS AND GASKET SET ASSY.

<u>NO.</u>	<u>PART NO.</u>	<u>PART NAME</u>	<u>QTY.</u>	<u>REMARKS</u>
4	11429907110	YANMAR LABEL	1	
7	11429907160	DIESEL LABEL	1	
10	11429992590	TOOL ASSY.....	1	INCLUDES ITEMS W/*
11*	11429992600	TOOL BAG	1	
12*	11429992710	SPANNA	1	
13*	11429992720	SPANNA	1	
14*	11429992730	DRIVER	1	
15*	11429992740	FUEL FITTING	1	
16	71411092600	GASKET SET .....	1	INCLUDES ITEMS W/#
17#	11429501330	CYLINDER HEAD GASKET ASSY.	1	
23#	11429901280	O- RING	1	
24#	11429901410	CRANK CASE GASKET	1	
25#	11429901950	O- RING	2	
26#	11425001841	GASKET	1	
27#	22190160002	WASHER SEAL 16S	2	
28#	11425011340	VALVE STEM SEAL	2	
29#	11477111461	NOZZLE GASKET	1	
30#	11477111310	BONNET GASKET	1	
31#	11429912210	AIR CLEANER GASKET	1	
32#	11477112200	AIR INTAKE GASKET	1	
33#	11429913200	MUFFLER GASKET	1	
34#	11429932570	O- RING, COVER	1	
35#	24341000100	O- RING 1A S-10.0	1	
36#	23414080000	PACKING 8	1	
37#	24341000224	O- RING 1A S- 22.4	1	
38#	24341000150	O- RING 1A S- 15.0	1	

# YANMAR L-48V6 ENGINE — ACCESSORIES ASSY.

ACCESSORIES ASSY.

SEE AIR CLEANER ASSY.

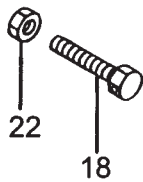
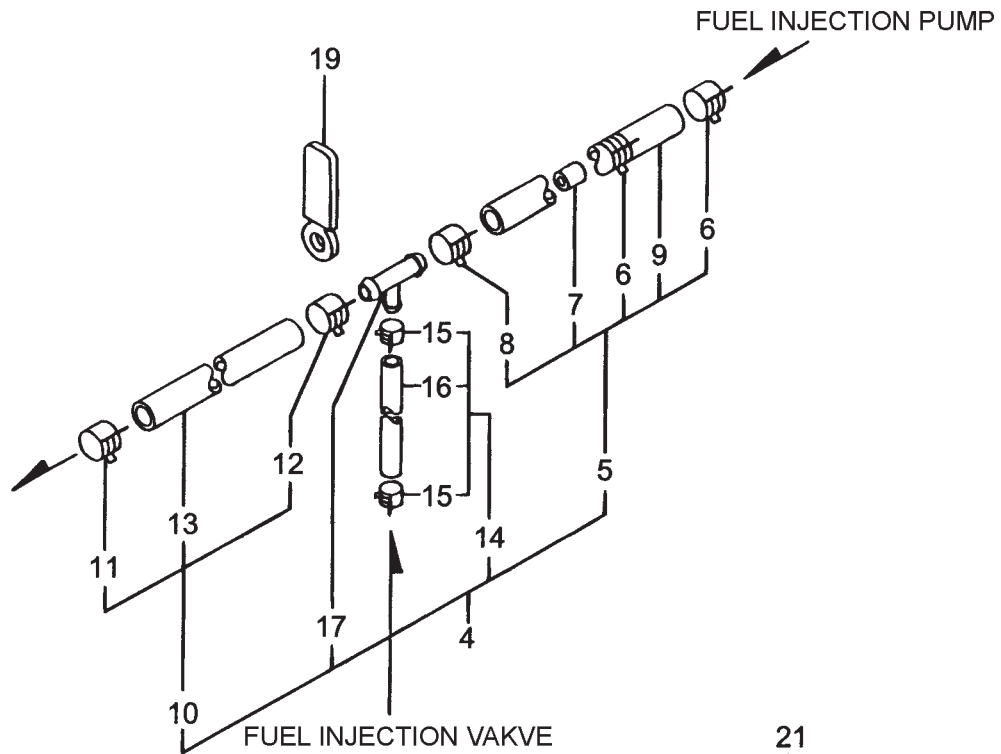
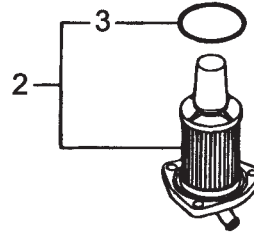
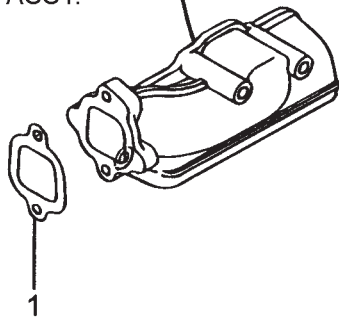

SEE CRANKSHAFT  
AND CAMSHAFT ASSY.

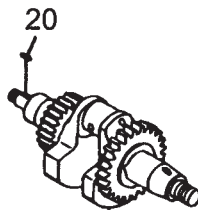

SEE CYLINDER  
BLOCK ASSY.

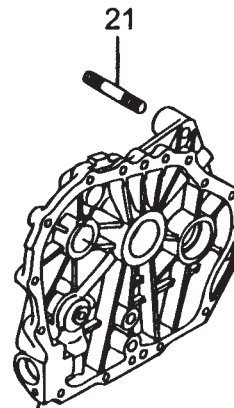

# YANMAR L-48V6 ENGINE — ACCESSORIES ASSY.

## ACCESSORIES ASSY.

<u>NO.</u>	<u>PART NO.</u>	<u>PART NAME</u>	<u>QTY.</u>	<u>REMARKS</u>
1	11428412200	AIR INTAKE GASKET	1	
2	18325455120	FUEL STRAINER ASSY. ....	1	INCLUDES ITEMS W/*
3*	24341000450	O- RING 1A S- 45.0	1	
4	11428459101	PIPE ASSY. FUEL OIL .....	1	INCLUDES ITEMS W/ #
5 #	11428459020	FUEL B. PIPE ASSY. ....	1	INCLUDES ITEMS W/ +
6+	10699044660	HOSE 12.5 BAND	2	
7+	18325059040	PIECE	1	
8+	12476659050	CLAMP 11.5	1	
9+	18325059051	FUEL OIL PIPE	1	
10 #	11428459030	FUEL A PIPE ASSY. ....	1	INCLUDES ITEMS W/ >
11 >	10699044660	HOSE 12.5 BAND	1	
12 >	12476659050	CLAMP 11.5	1	
13 >	18326659050	RUBBER HOSE 8X13X255	1	
14 #	11428459040	FUEL C PIPE ASSY. ....	1	INCLUDES ITEMS W/ %
15%	12472259050	CLAMP 9	2	
16%	11465459070	FUEL RETURN PIPE	1	
17 #	11428459710	JOINT	1	
18	11425066440	ADJUSTING BOLT	1	
19	16071078710	CORD CLAMP	2	
20	22512040120	KEY 4X 12	1	
21	26226100452	STUD BOLT	2	
22	26757060002	LOCK NUT M 6 PLATED	1	