

PARTS MANUAL



Mikasa **SERIES**
MODEL MT-65H
TAMPING RAMMER
(HONDA GASOLINE ENGINE)

Revision #5 (10/07/20)

THIS MANUAL MUST ACCOMPANY THE EQUIPMENT AT ALL TIMES.

MT-65H— SUGGESTED SPARE PARTS

MT-65H RAMMER - 1 TO 3 UNITS WITH HONDA GX100KRB ENGINE

Qty.	P/N	Description
1	362455630	LEVER, THROTTLE
1	956100043	THROTTLE WIRE
3	362030030	ELEMENT, AIR CLEANER
3	362030020	PACKING, AIR CLEANER
3	362456610	ELEMENT, CRANKCASE
1	361910070	CAP, FUEL TANK W/ STRAP
1	954300720	COCK, FUEL ASSY.
2	16910GB2005 ..	FILTER, IN-LINE FUEL
3	17200ZL8003 ...	ELEMENT, SET ENGINE
1	36100ZE1015 ..	STOP, SWITCH
3	9805655757	SPARK PLUG
1	954406010	STRAINER, FUEL TANK
1	28462Z0DV02 ..	ROPE, RECOIL STARTER

MT-65H RAMMER - 3 TO 5 UNITS WITH HONDA GX100KRB ENGINE

Qty.	P/N	Description
1	362455630	LEVER, THROTTLE
1	956100043	THROTTLE WIRE
3	362030030	ELEMENT, AIR CLEANER
5	362030020	PACKING, AIR CLEANER
3	362456610	ELEMENT, CRANKCASE
2	354336352	CLAMP, BELLOWS
1	354010010	BELLOWS
1	361910070	CAP, FUEL TANK W/ STRAP
1	954300720	COCK, FUEL ASSY.
2	16910GB2005 ..	FILTER, IN-LINE FUEL
3	17200ZL8003 ...	ELEMENT, SET ENGINE
1	36100ZE1015 ..	STOP, SWITCH
3	9805655757	SPARK PLUG
1	362454441	CLUTCH
1	14400ZOD03 ...	BELT, TIMING
2	28462Z0DV02 ..	ROPE, RECOIL STARTER

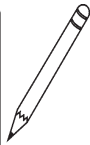

Part numbers on this Suggested Spare Parts List may supersede/replace the P/N shown in the text pages of this book.

MT-65H— NAMEPLATE AND DECALS

NAME PLATE AND DECALS

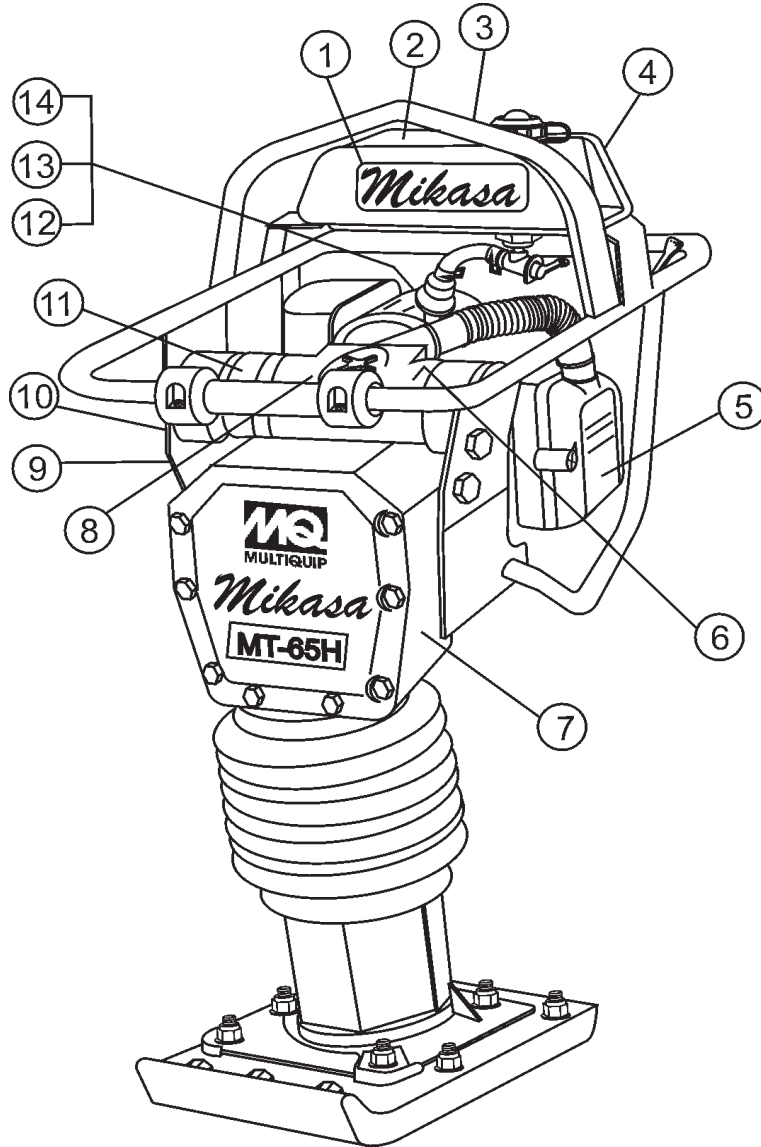

MT-65H— NAMEPLATE AND DECALS

NAME PLATE AND DECALS

<u>NO</u>	<u>PART NO</u>	<u>PART NAME</u>	<u>QTY.</u>	<u>REMARKS</u>
1*	920106460	DECAL: MIKASA LOGO	1	
2*	920203290	DECAL: READ MANUAL	1	NPA329
3*	920210170	DECAL: GASOLINE ONLY	1	NPA1017
4*	920209750	DECAL: CAUTION/OPERATION	1	NPA975
5*	920210160	DECAL: SECONDARY AIR FILTER .	1	NPA1016
6*	920209630	DECAL: CLEANING ELEMENT	1	NPA963
7		DECAL: NAMEPLATE	1	CONTACT MQ PARTS DEPT. W/MODEL & S/N
8*	920210180	DECAL: PRIMARY AIRFILTER	1	NPA1018
9*	920207690	DECAL: CAUTION READ MANUAL .	1	NPA769
10*	920209100	DECAL: RAMMER, BOOT, HEARING ...	1	NPA910
11*	920209610	DECAL: OIL 7~9 cc	1	NPA961
12*	920203990	DECAL: FUEL COCK	1	NPA399
13*	920202930	DECAL: START SWITCH	1	NPA293
14*	920209570	DECAL: 3800~4100 RPM	1	NPA957
	DCLMT65H	KIT, DECAL	1	INCLUDES ITEMS W/ *

SEE DECAL ILLUSTRATIONS ON PAGE 10.

MT-65H — CRANKCASE AND ENGINE ASSY.

CRANKCASE AND ENGINE ASSY.

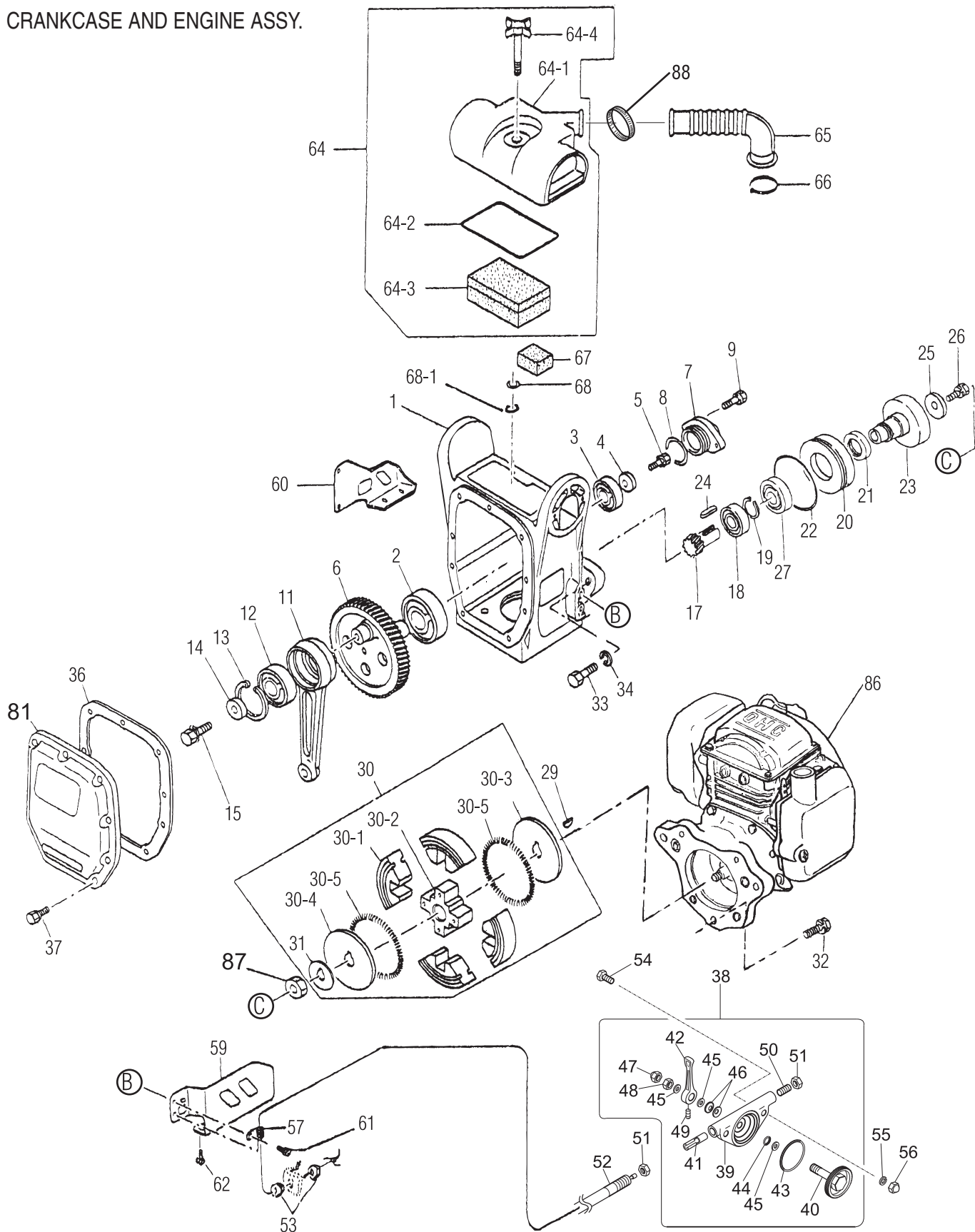

MT-65H — CRANKCASE AND ENGINE ASSY.

CRANKCASE AND ENGINE ASSY.

<u>NO.</u>	<u>PART NO.</u>	<u>PART NAME</u>	<u>QTY.</u>	<u>REMARKS</u>
1	363117950	CRANK CASE	1	
2	040006207	BEARING 6207	1	
3	0600200020	BEARING 6204	1	REPLACES P/N 040006204
4	952400130	WASHER 9304	1	
5	011708025	BOLT 8X25 H,SW	1	REPLACES P/N 002210825
6	363342430	CRANK GEAR	1	
6	363342750	CRANK GEAR	1	S/N K1687 AND ABOVE
7	363456230	BEARING COVER	1	
8	050300440	O-RING S-44	1	
9	011008020	BOLT 8X20 H, SW	2	REPLACES P/N 002210820
11	371334730	CONNECTING ROD	1	
12	040006304	BEARING 6304	1	
13	080100520	STOP RING R-52	1	
14	952400130	WASHER 9304	1	
15	002210825	BOLT 8X25 H, SW	1	
17	363456220	PINION	1	
17	363456410	PINION	1	S/N K1687 AND ABOVE
18	0600200020	BEARING 6204	1	REPLACES P/N 040006204
19	080200350	STOP RING S-35	1	
20	352441340	SPACER	1	
21	060404010	OIL SEAL TC-40528	1	
22	050100950	O-RING G-95	1	
23	355447210	CLUTCH DRUM	1	
24	952405610	KEY 5X5X19R	1	
25	952405490	LOCK WASHER	1	
26	011008020	BOLT 8X20 H, SW	1	REPLACES P/N 002210820
27	041006007	BEARING 60072	1	
29	0053204201	WOODRUFF KEY	1	
30	362454441	CLUTCH AY/CE120P	1	INCLUDES ITEMS W/+
30-1 +	943020020	CLUTCH SHOE C812	4	
30-2 +	943050050	CLUTCH BOSS C812	1	
30-3 +	943060100	CLUTCH GUIDE (A) 1.6T, 1C	1	
30-4 +	943060020	CLUTCH GUIDE /B	1	
30-5 +	943030021	CLUTCH SPRING	2	
31 +	301010210	LOCK WASHER, CLUTCH	1	
32	012710035	BOLT 10X35 H, SW	1	REPLACES P/N 002211035
33	001111040	BOLT 10X40	2	
34	030210250	WASHER, SW M10	2	
36	363342490	PACKING, FRONT COVER	1	
37	011706020	BOLT 6X20 H, SW	9	REPLACES P/N 002210620
38	362910060	THROTTLE LEVER ASSY	1	INCLUDES ITEMS W/ *
39*	362341550	THROTTLE BODY	1	
40*	362910090	THROTTLE GEAR CP, W/ BOLT	1	

MT-65H — CRANKCASE AND ENGINE ASSY.

CRANKCASE AND ENGINE ASSY.

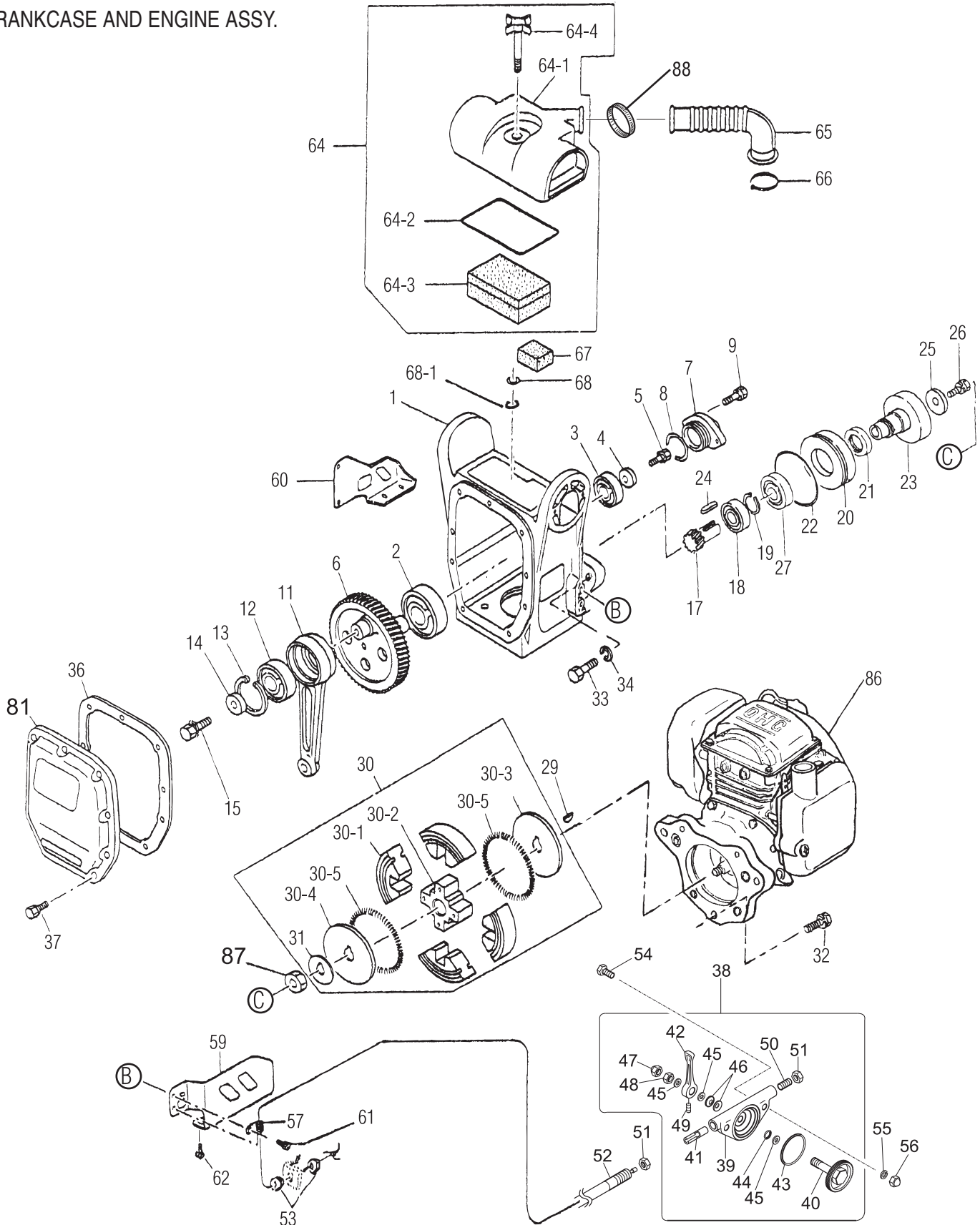

MT-65H — CRANKCASE AND ENGINE ASSY.

CRANKCASE AND ENGINE ASSY.

<u>NO.</u>	<u>PART NO.</u>	<u>PART NAME</u>	<u>QTY.</u>	<u>REMARKS</u>
41*	362455620	SLIDER	1	
42*	362455630	THROTTLE LEVER	1	
43*	050100450	O-RING G-45	1	
44*	050200100	O-RING P-10	2	
45*	031110160	WASHER, PW M10	3	
46*	032110180	CONICAL SPRING WASHER	2	REPLACES P/N 033910070
47*	022131008	CAP NUT M10	1	
48*	020410060	NUTM10, H=6	1	
49	096206006	SOCKET HEAD SCREW 6X6	1	
50	096208020	SOCKET HEAD SCREW 8X20	1	
51	020408050	NUT M8, H=5	2	
52	956100043	THROTTLE WIRE 720-850	1	
53	020108060	NUT M6	2	REPLACES P/N 020406040
54	011206020	BOLT 6X20 T	2	REPLACES P/N 001220620
55	030206150	WASHER, SW M6	2	
56	022130605	CAP NUT M6	2	
57	959006120	CLIP (TCP2-10509B)	1	
59	363342520	LINK PROTECTOR	1	
60	363342530	MUFFLER PROTECTOR	1	
61	002400820	BOLT 8X20 SW, PW	4	
62	002400825	BOLT 8X25 SW, PW	4	
64	362116870	AIR CLEANER ASSY.	1	INCLUDES ITEMS W/ #
64-1#	362030011	COVER CP, AIR CLEANER	1	
64-2#	362030020	PACKING, AIR CLEANER	1	
64-3#	362030030	ELEMENT CP, AIR CLEANER	1	
64-4#	362030040	BOLT CP, AIR CLEANER	1	
65	353342400	INTAKE PIPE	1	
66	507010110	CLAMP TC-200	2	
67	362456610	ELEMENT BREATHER	1	
68	031108160	WASHER, PW M8	1	
68-1	050300070	O-RING (S-7)	1	
81	363030010	FRONT COVER MQ	1	
86	912210002	ENGINE ASSY. GX100KRB	1	
87	94002120000S	NUT M121	1	
88	64016	HOSE CLAMP 13x16, 1-1/2" SS	1	

MT-65H — GUIDE CYLINDER AND SPRING ASSY.

GUIDE CYLINDER AND FOOT ASSY.

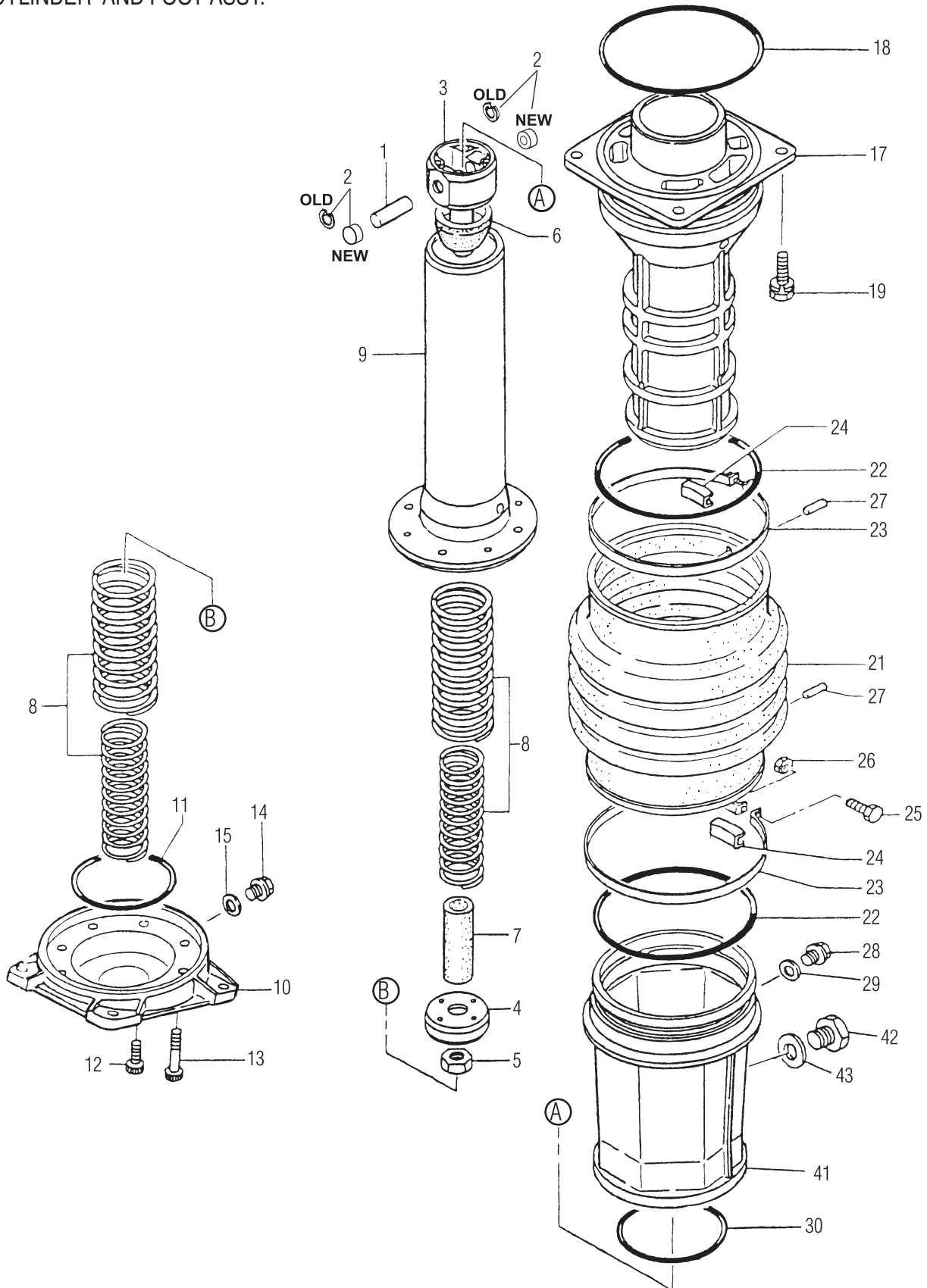

MT-65H — GUIDE CYLINDER AND SPRING ASSY.

GUIDE CYLINDER AND FOOT ASSY.

<u>NO.</u>	<u>PART NO.</u>	<u>PART NAME</u>	<u>QTY.</u>	<u>REMARKS</u>
1	352423290	PISTON PIN	1	
2	080100150	STOP RING R-15	2	S/N M1024 AND BELOW
2	363457870	PLUG, PISTON PIN	2	S/N M1025 AND ABOVE
3	363342450	PISTON ROD	1	S/N M1024 AND BELOW
3	363344350	PISTON ROD	1	S/N M1025 AND ABOVE
4	355452340	PISTON END	1	
5	020118150	NUT M18, P1.5	1	
6	355447250	STOPPER, UPPER	1	
7	355447260	STOPPER, LOWER	1	
8	363456260	MAIN SPRING	2	
9	363342440	SPRING CYLINDER	1	
10	355214140	FOOT PLATE 14	1	
11	050100900	O-RING G-90	1	
12	014210020	SOCKET HEAD BOLT 10X20 T ...	4	REPLACES P/N 001521020
13	014210040	SOCKET HEAD BOLT 10X40 T ...	4	REPLACES P/N 001521040
14	953405270	PLUG 1/4X14 13L	1	
15	953405260	PACKING 1/4 (CU)	1	
17	355213010	GUIDE CYLINDER	1	
18	050201500	O-RING P-150	1	
19	012710035	BOLT 10X35 H, SW	4	REPLACES P/N 002211035
21	354010010	BELLOWS, ORANGE	1	
22	050931500	O-RING JAS03150	2	
23	354336352	BELLOWS CLAMP (1.6T)171D	2	
24	354442340	BAND GUIDE, BELLOWS	2	
25	011008040	BOLT 8X40 H	2	REPLACES P/N 001210840
26	020108060	NUT M8	2	REPLACES P/N 020308060
27	354446170	PIN 6D-8.5L	2	
28	953405270	PLUG 1/4X14 13L	1	
29	953405260	PACKING 1/4 (CU)	1	
30	050100950	O-RING G-95	1	
41	355113960	PROTECTION SLEEVE	1	
42	959010150	LEVEL GAUGE, PLUG TYPE	1	
43	953404670	COPPER PACKING 17X25.5X1	1	

MT-65H — FOOT ASSY.

FOOT ASSY.

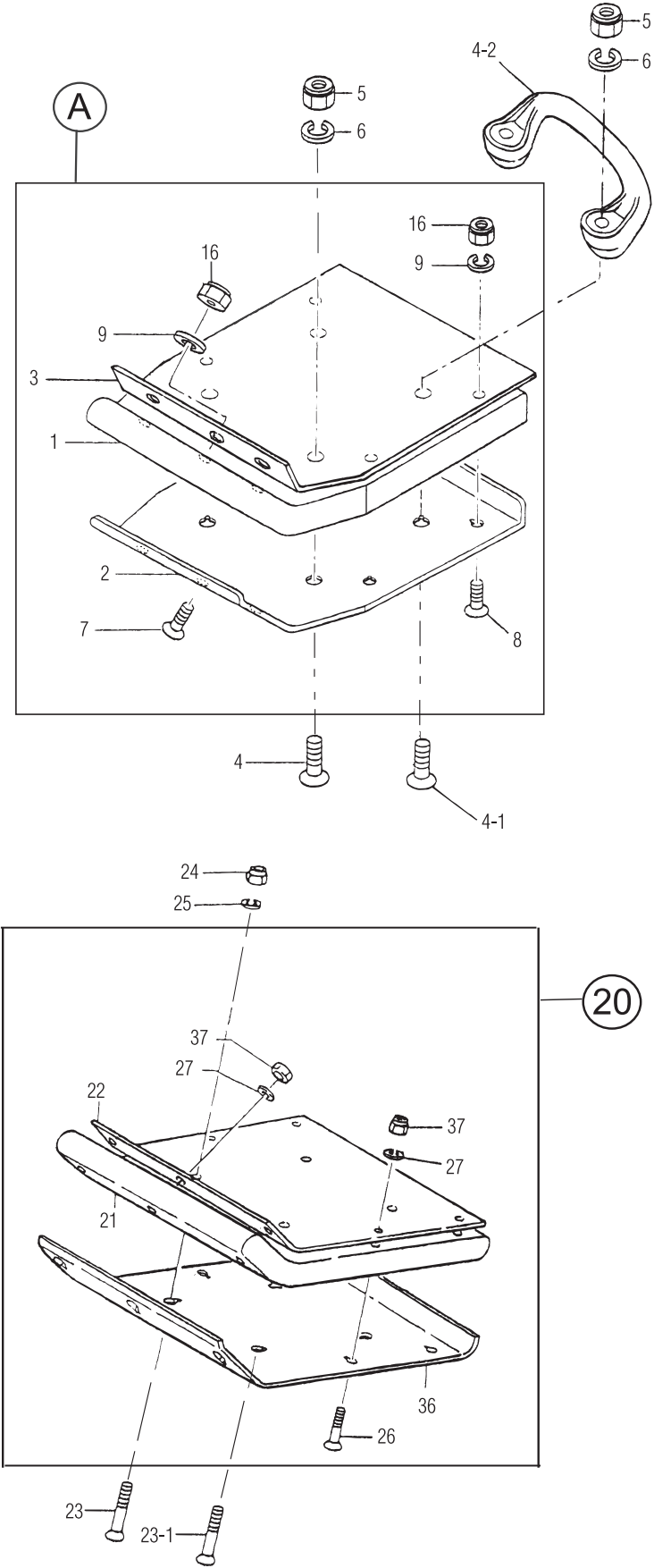

FOOT ASSY.

<u>NO.</u>	<u>PART NO.</u>	<u>PART NAME</u>	<u>QTY.</u>	<u>REMARKS</u>
A	362910080	FOOT ASSY 285	1	INCLUDES ITEMS W/#
1#	363342460	FOOT	1	
2#	363342470	METAL SHEET	1	
3#	363342480	FOOT COVER	1	
4	001611253	SUNK HEAD BOLT 12 x 65	2	S/N K4760 AND ABOVE
4-1	001611259	SUNK HEAD BOLT 12 X 95	2	S/N K4760 AND ABOVE
4-2	363343390	HANDLE	1	
5	022711214	NYLON NUT M12	4	
6	030212300	WASHER, SW M12	4	
7#	001611051	SUNK HEAD BOLT 10 x 55 H	3	
8#	015110050	SUNK HEAD BOLT 10 x 50	4	
9#	030210250	WASHER, SW M10	7	
16#	022711012	NYLON NUT M10	7	
20	352910033	FOOT ASSY.	1	INCLUDES ITEMS W/ *
21*	352108220	FOOT 285B-331L	1	
22*	352333380	FOOT COVER	1	
23	001611253	SUNK HEAD BOLT 12 x 65	4	S/N K4759 AND BELOW
23	001611253	SUNK HEAD BOLT 12 x 65	2	S/N K4760 AND ABOVE
23-1	001611259	SUNK HEAD BOLT 12 x 65	2	S/N K4760 AND ABOVE
24	022711214	NYLON NUT M12	4	
25	030212300	WASHER, SW M12	4	
26*	001611051	SUNK HEAD BOLT 10 x 55 H	7	
27*	030210250	WASHER, SW M10	7	
36	352108230	METAL SHEET	1	
37	022711012	NYLON NUT M10	7	

MT-65H — TANK AND HANDLE ASSY.

TANK AND HANDLE ASSY.

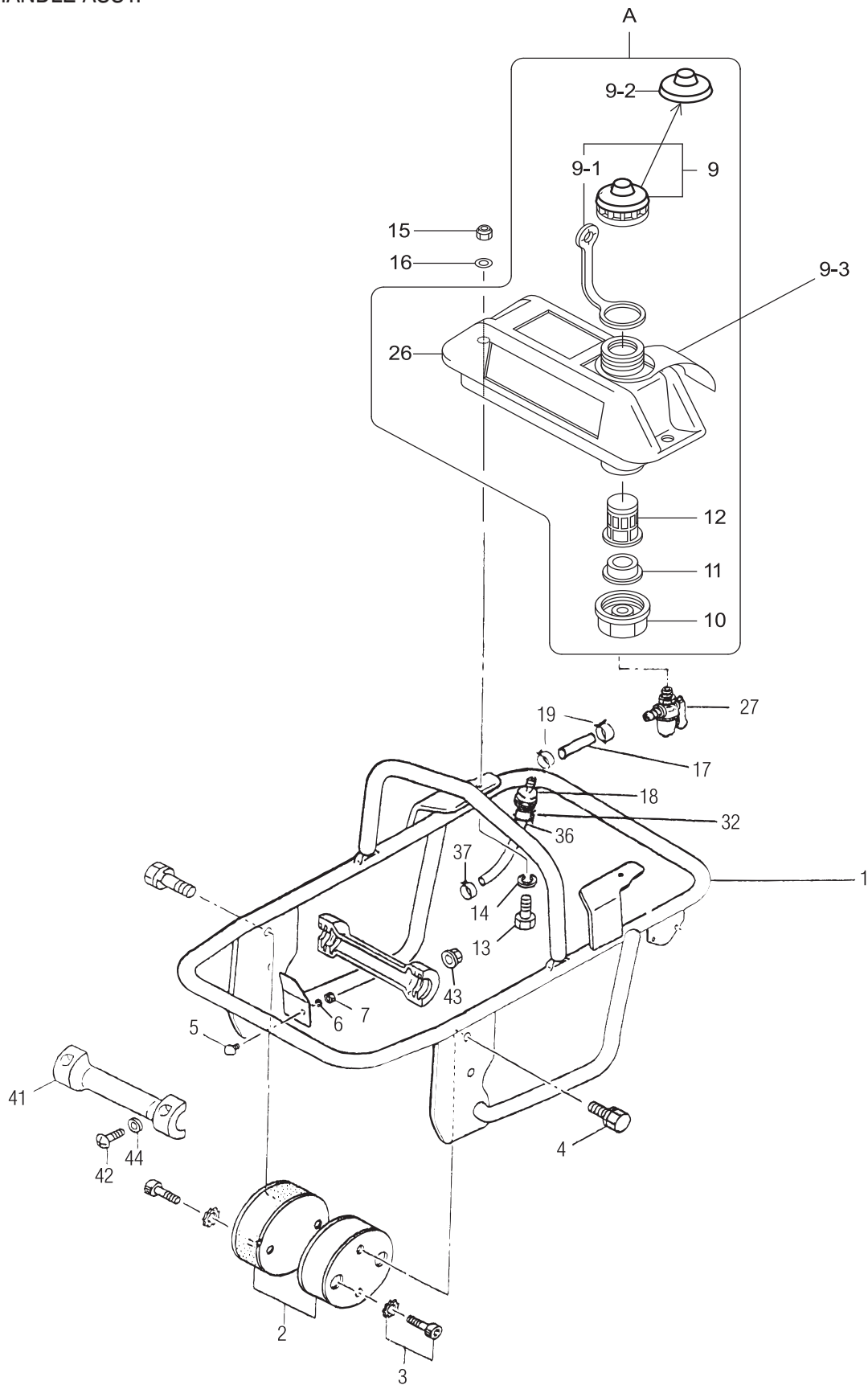

MT-65H — TANK AND HANDLE ASSY.

TANK AND HANDLE ASSY.

<u>NO.</u>	<u>PART NO.</u>	<u>PART NAME</u>	<u>QTY.</u>	<u>REMARKS</u>
A	305910032	FUEL TANK ASSY	1	INCLUDES ITEMS W/ #
1	363117300	HANDLE	1	
2	351337070	SHOCK ABSORBER	2	
3	009110007	GT CAP SA,10X20	4	
4	012210020	BOLT 10X20 H,SW	4	REPLACES P/N 02211020
5	939010210	STOPPER RUBBER EH1002	1	
6	030208200	WASHER, SW M8	1	
7	020108060	NUT M8	1	REPLACES P/N 020308060
9#	361910070	TANK CAP ASSY	1	REPLACES P/N 361910021 INCLUDES ITEMS W/ \$
9-1#\$	353449010	STRAP, TANK CAP	1	
9-2#\$	361455740	SUB CAP (B), TANK CAP	1	
9-3	920208960	TAG, GASOLINE ONLY	1	
10#	351437785	HOLDER, COCK/MT	1	
11#	954406020	PACKING, FUEL TANK	1	
12#	954406010	STRAINER (#110)	1	
13	011208030	BOLT 8X30 T	2	REPLACES P/N 020308060
14	030208200	WASHER, SW M8	2	
15	022710809	NYLON NUT M8	2	
16	952401450	WASHER 8, 5X22X3	2	
17	959026401	FUEL HOSE/4.5 X9 X 80L	1	
17	959026103	FUEL HOSE/5.5 X 11.5 X80L	1	OPTIONAL PART
18	16910GB2005	FUEL FILTER CP/G100KRB	1	
19	954407060	HOSE BAND 9	2	
19	954406420	HOSE BAND 10.5	2	OPTIONAL PART
26#	362116890	FUEL TANK 2L (GRAY)	1	
27	954300720	FUEL COCK ASSY/ CVL-08	1	
32	954407060	HOSE BAND 9	1	
36	363456340	FUEL HOSE/4.5X9X210L	1	
36	959026199	FUEL HOSE/ 5.5X10.5X1000L ..	1	OPTIONAL PART L=1M
37	301420730	HOSE BAND 8	2	REPLACES P/N 954403030
37	954406420	HOSE BAND 10.5	2	OPTIONAL PART
41	361910040	ROLLER, W/PIN	1	REPLACES P/N 955200053
42	011005025	SCREW 5X25	4	REPLACES P/N 091005025
43	022610505	FLANGE NUT M5 H	4	
44	58151	WASHER, PW M5	4	REPLACES P/N 031105080

HONDA GX100KRB ENGINE — CYLINDER BARREL ASSY.

CYLINDER BARREL ASSY.

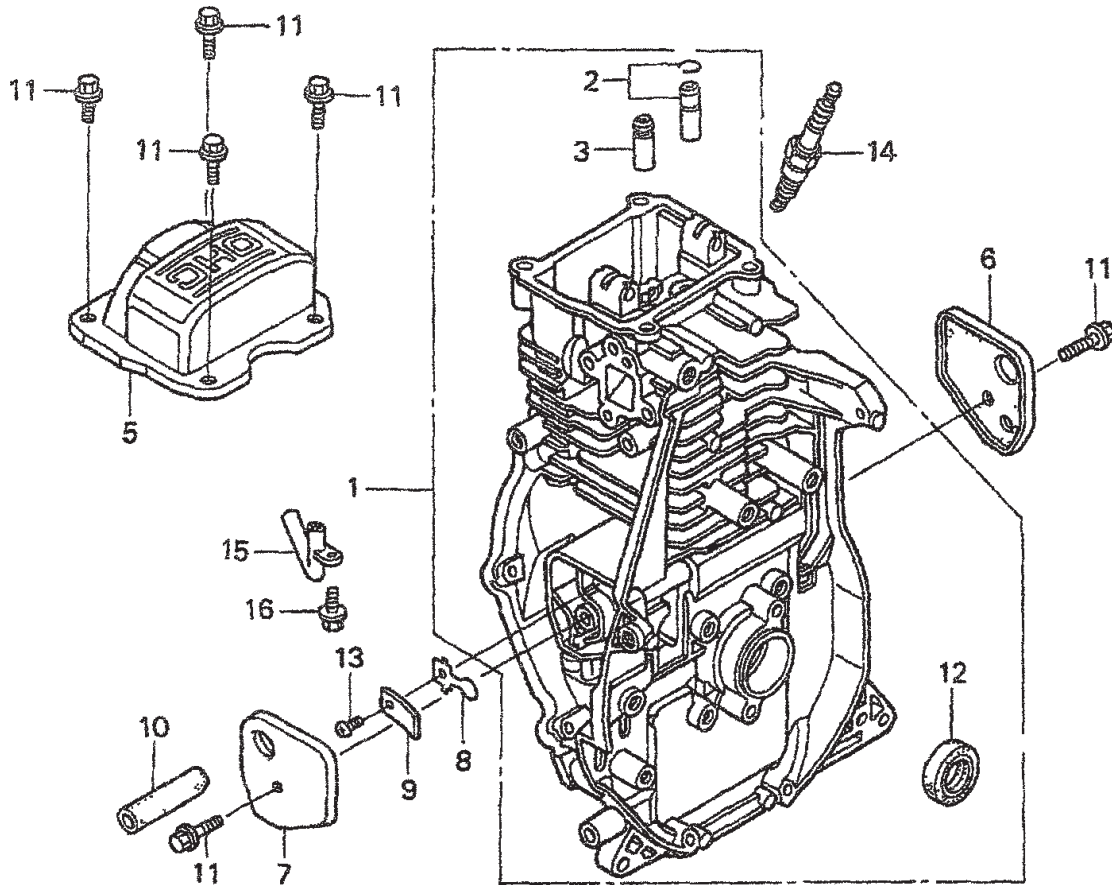

HONDA GX100KRB ENGINE — CYLINDER BARREL ASSY.

CYLINDER BARREL ASSY.

<u>NO.</u>	<u>PART NO.</u>	<u>PART NAME</u>	<u>QTY.</u>	<u>REMARKS</u>
1	12000Z0D405	BARREL ASSY., CYLINDER	1	INCLUDES ITEMS W/
2*	12201Z0D305	GUIDE ASSY., EX VALVE (O.S.)	1	
3*	12204Z0D305	GUIDE, INLET VALVE (O.S)	1	
5	12311Z0D000	COVER, HEAD T	1	
6	12355Z0D000	COVER COMP A, BREATHER	1	
7	12365Z0D000	COVER COMP B, BREATHER	1	
8	15571Z0DV71	VALVE, OIL OUTLET	1	
9	15572ZM7000	PLATE, STOPPER	1	
10	15721Z0D000	TUBE, BREATHER	1	
11	90014952000	VOLT, FLANGE 6X14 (CT200)	6	
12*	91202KJ9003	OIL SEAL 20X32X6	1	
13	93500030050A	SCREW 3X5	1	
14	9805655757	PLUG, SPARK (U16FSR-UB)	1	
15	15171Z0DV00	PIPE, BREATHER	1	
16	90008ZM7000	BOLT 4X10	1	

HONDA GX100KRB ENGINE — CRANKCASE COVER ASSY.

CRANKCASE COVER ASSY.

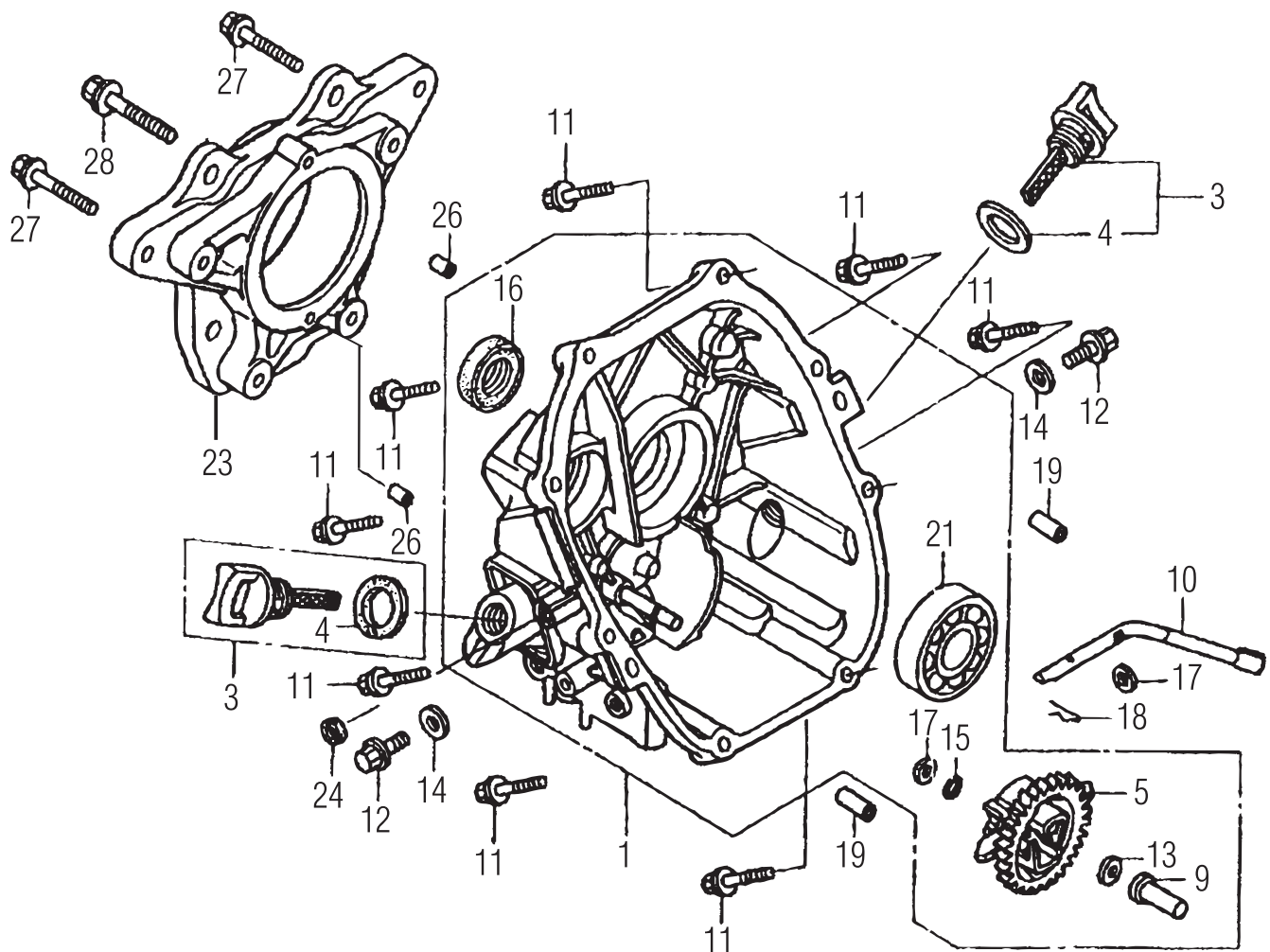

HONDA GX100KRB ENGINE — CRANKCASE COVER ASSY.

CRANKCASE COVER ASSY.

<u>NO.</u>	<u>PART NO.</u>	<u>PART NAME</u>	<u>QTY.</u>	<u>REMARKS</u>
1	11300Z0D409	COVER ASSY., CRANK CASE ..	1	INCLUDES ITEMS W/*
3	15600ZM7003	OIL FILLER CAP ASSY	1	INCLUDES ITEMS W/#
4#	15625ZE1003	PACKING, OIL FILLER CAP	1	
5*	16510ZL8000	GOVERNOR ASSY.	1	
9*	16531ZE1000	SLIDER, GOVERNOR	1	
10	16541Z0D000	SHAFT, GOVERNOR ARM	1	
11	90121952000	FLANGE BOLT 6x25	8	
12	90131ZE1000	BOLT, DRAIN PLUG	1	
13*	90451ZE1000	THRUST WASHER 6 MM	1	
14	90601ZE1000	WASHER, DRAIN PLUG	1	
15*	90602ZE1000	CLIP, GOVERNOR HOLDER	1	
16*	91202KJ9003	OIL SEAL 20x3x6	1	
17*	9410106800	PLAIN WASHER 6 MM	2	
18	9425108000	LOCK PIN	1	
19	9430108200	KNOCK PIN	2	
21*	961006204000	BEARING, RADIAL BALL 6204	1	
23	11511Z0DV10	FLANGE JOINT PTO	1	
24	91231891003	OIL SEAL 6x11x4	1	
26	9430306100	KNOCK PIN 6x10	2	
27	957010804500	FLANGE BOLT 8x40	4	
28	934021004000	BOLT WASHER 10x40	2	

HONDA GX100KRB ENGINE — CRANKSHAFT ASSY.

CRANKSHAFT ASSY.

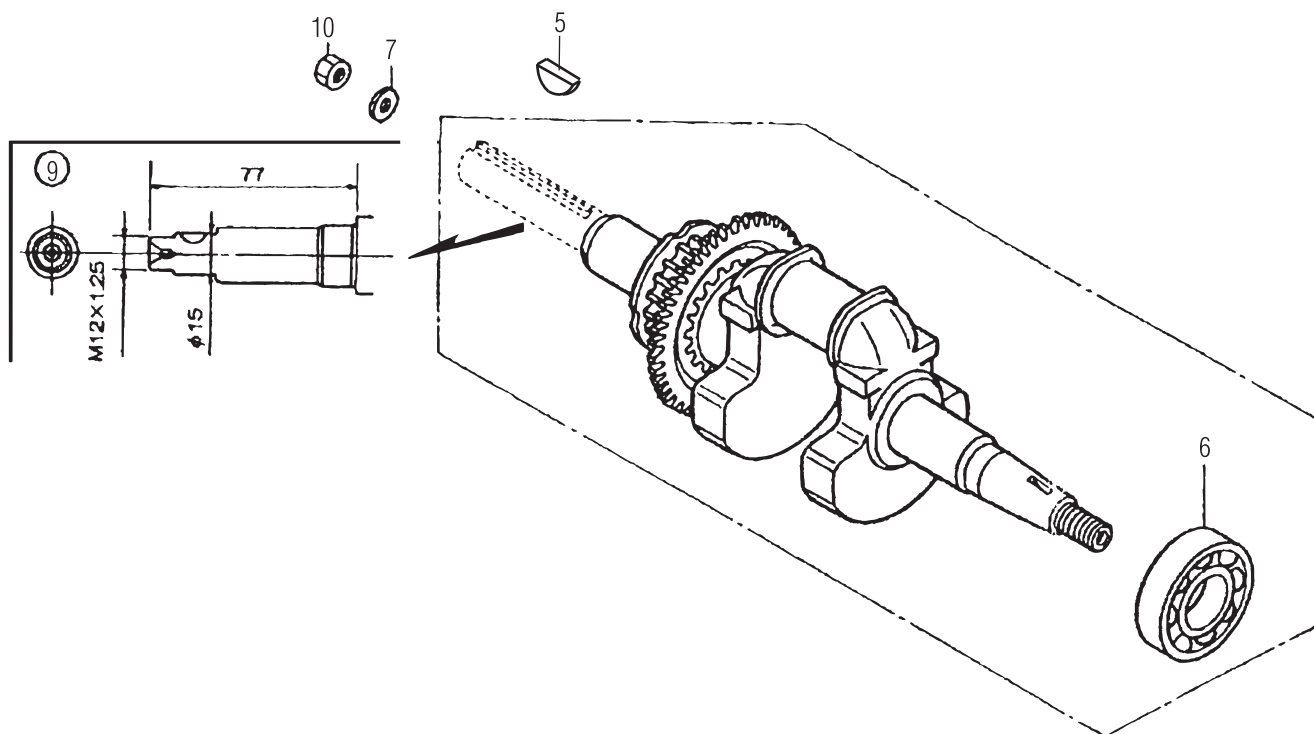

HONDA GX100KRB ENGINE — CRANKSHAFT ASSY.

CRANKSHAFT ASSY.

<u>NO.</u>	<u>PART NO.</u>	<u>PART NAME</u>	<u>QTY.</u>	<u>REMARKS</u>
5	0053204201	WOODRUFF KEY 13X12	1	
6*	91001Z0DV01	BEARING, RADIAL BALL 6204C2		
7	301010210	LOCK WASHER, CLUTCH	1	
9	13310Z0DV00	CRANK SHAFT COMP.	1	INCLUDES ITEM W/ *
10	94002120000S	NUT M12	1	

HONDA GX100KRB ENGINE — PISTON CONNECTING ROD ASSY.

PISTON CONNECTING ROD ASSY.

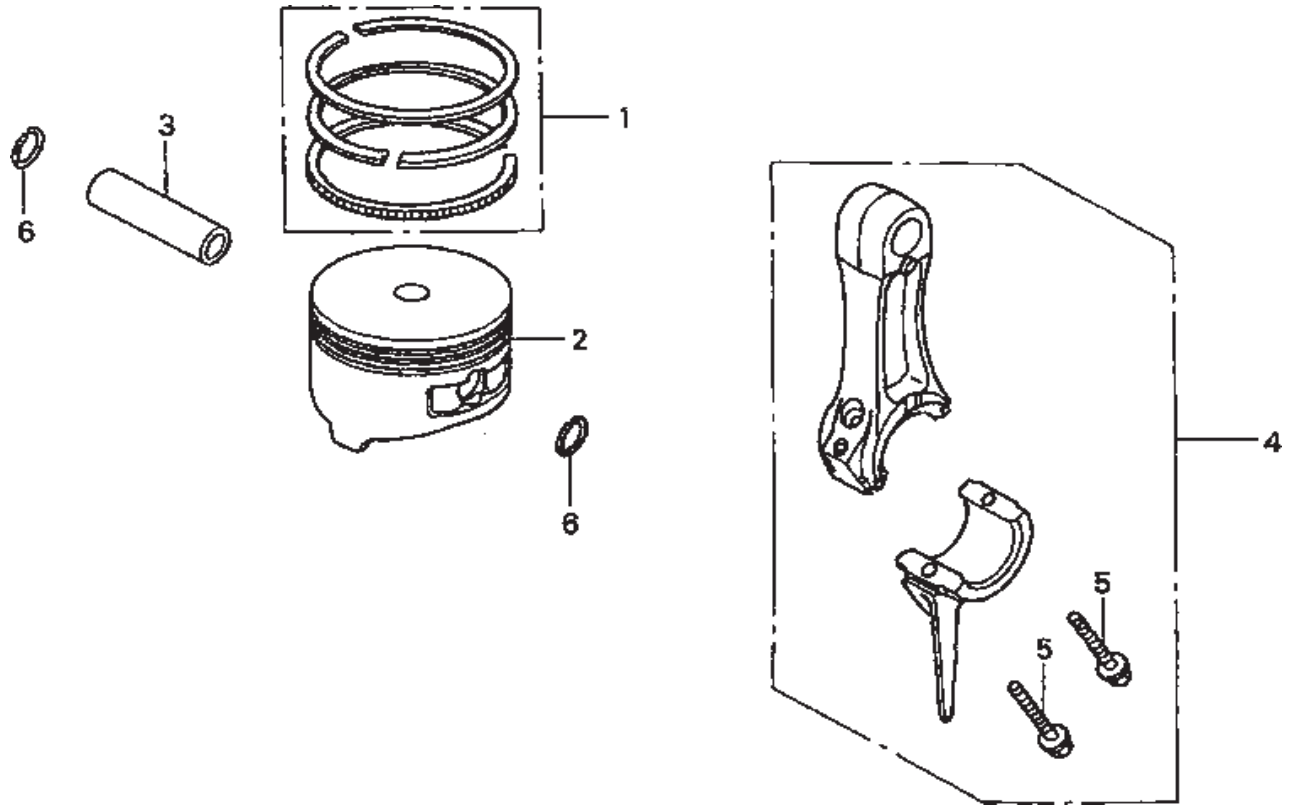

HONDA GX100KRB ENGINE — PISTON CONNECTING ROD ASSY.

PISTON CONNECTING ROD ASSY.

<u>NO.</u>	<u>PART NO.</u>	<u>PART NAME</u>	<u>QTY.</u>	<u>REMARKS</u>
1	13010Z0D003	RING SET, PISTON	1	
2	13101Z0D000	PISTON	1	
3	13111ZE0000	PISTON PIN	1	
4	13200Z0D000	CONNECTING ROD ASSY.	1	INCLUDES ITEM W/ *
4	13200Z0D305	CONNECTING ROD ASSY.	1	UNDERSIZE, INCLUDES ITEM W/ *
5*	90001ZM7000	CONNECTING ROD BOLT	2	
6	90551ZE0000	CLIP, PISTON PIN 13MM	2	

HONDA GX100KRB ENGINE — CAMSHAFT ASSY.

CAMSHAFT ASSY.

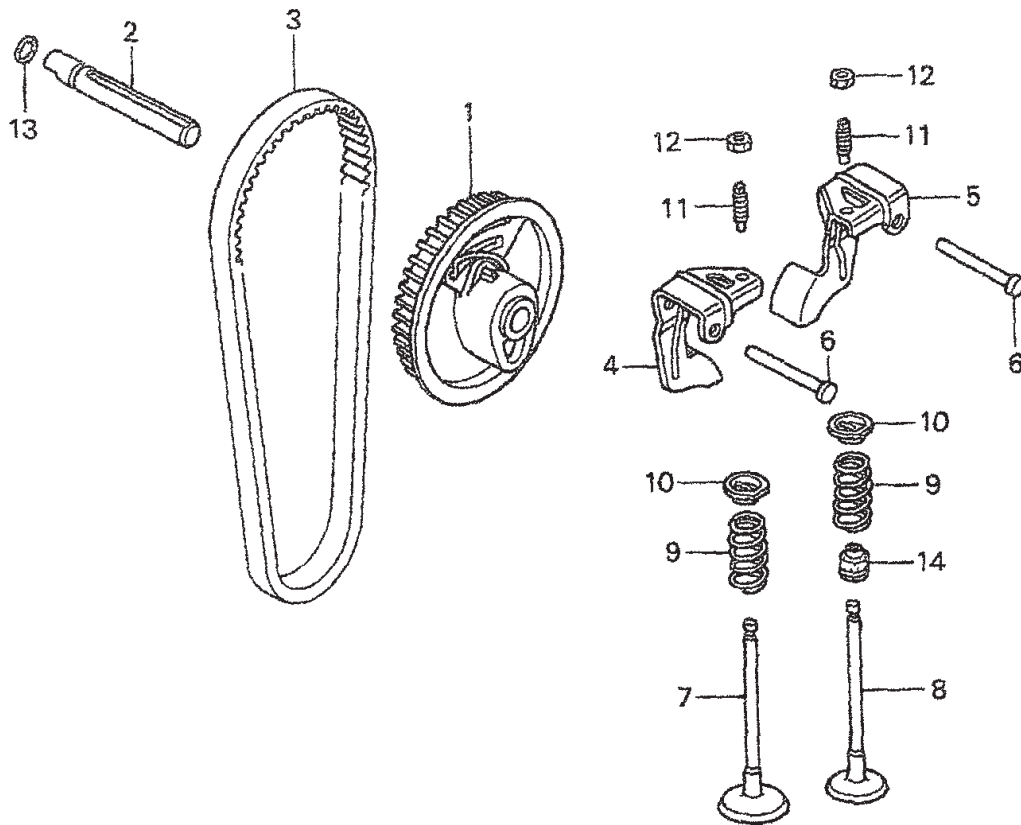

HONDA GX100KRB ENGINE —CAMSHAFT ASSY.

CAMSHAFT ASSY.

<u>NO.</u>	<u>PART NO.</u>	<u>PART NAME</u>	<u>QTY.</u>	<u>REMARKS</u>
1	14320Z0D000	PULLEY COMP., CAMSHAFT ...	1	S/N 1144521
1	14320Z0D010	PULLEY, COMP., CAMSHAFT ..	1	S/N 1144522 AND ABOVE
2	14324Z0D000	SHAFT, CAM PULLEY	1	
3	14400Z0D003	TIMING BELT (61YU7 G-200)	1	
4	14431Z0D000	ROCKER ARM, INTAKE VALVE	1	
5	14441Z0D000	ROCKER ARM, EXHAUST VALVE	1	
6	14461ZL8000	SHAFT, ROCKER ARM	2	
7	14711Z0D000	INLET VALVE	1	
8	14721Z0D000	EXHAUST VALVE	1	
9	14751Z0D000	SPRING, VALVE	2	
10	14771ZM3010	RETAINER, VALVE SPRING	2	
11	90012333000	SCREW, TAPPET ADJUSTING	2	
12	90206001000	NUT, TAPPET ADJUSTING	2	
13	91301ZM0V31	O RING 6.8X1.9	1	
14	12209KT7013	SEAL, VALVE STEM	1	

HONDA GX100KRB ENGINE — RECOIL STARTER ASSY.

RECOIL STARTER ASSY.

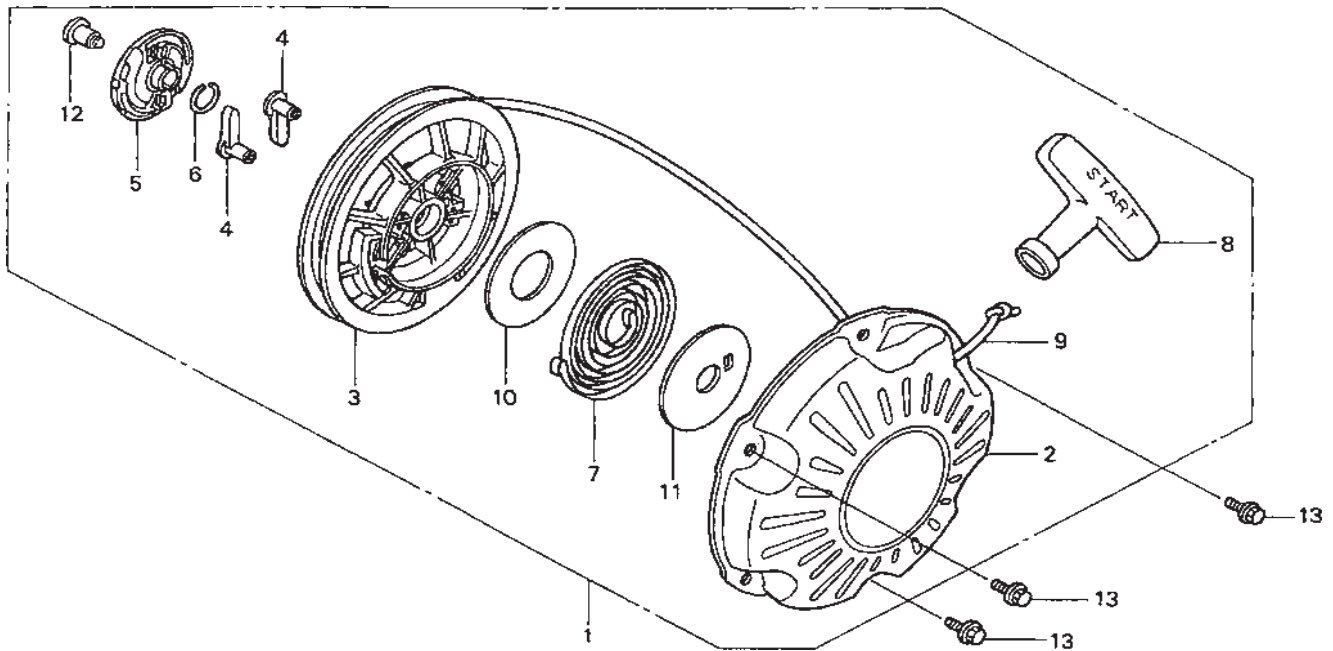

HONDA GX100KRB ENGINE — RECOIL STARTER ASSY.

RECOIL STARTER ASSY.

<u>NO.</u>	<u>PART NO.</u>	<u>PART NAME</u>	<u>QTY.</u>	<u>REMARKS</u>
1	28400Z0DV02ZA	RECOIL STARTER AY/GX100 (B)	1	INCLUDES ITEMS W/ *
2*	28410Z0DV02ZA	CASE COMP., RECOIL *5-3-5	1	
3*	28421Z0DV02	REEL, RECOIL STARTER	1	
4*	28422ZG0W02	RATCHET, STARTER	1	
5*	28433ZG0W02	GUIDE, RATCHET	1	
6*	28441ZW6003	SPRING, FRICTION	1	
7*	28442ZH8003	SPRING, RECOIL STARTER	1	
8*	28461ZH8003	STARTER KNOB	1	
9*	28462Z0DV02	ROPE, RECOIL STARTER	1	
10*	28467Z0DV02	PLATE, SIDE	1	
11*	28468Z0DV02	PLATE, SLIDE	1	
12*	90003ZH8003	SET SCREW	1	
13	957010600800	BOLT, FLANGE 6X8	1	

HONDA GX100KRB ENGINE — FAN COVER ASSY.

FAN COVER ASSY.

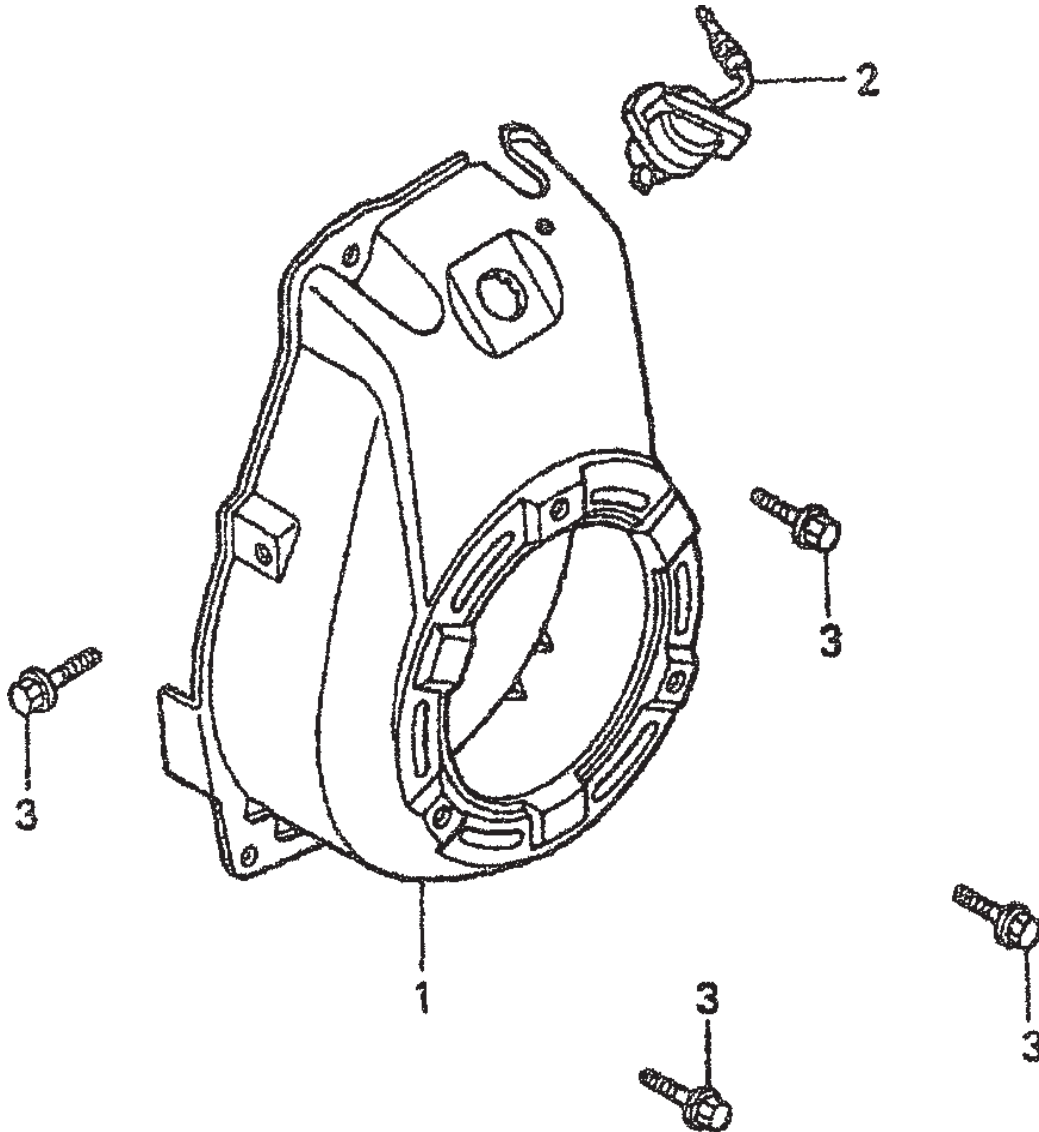

HONDA GX100KRB ENGINE — FAN COVER ASSY.

FAN COVER ASSY.

<u>NO.</u>	<u>PART NO.</u>	<u>PART NAME</u>	<u>QTY.</u>	<u>REMARKS</u>
1	19610Z0DV00ZB	FAN COVER CP.,	1	
2	36100ZE1015	STOP SWITCH ASSY.	1	
3	90014952000	BOLT, FLANGE 6X14 (CT200)	4	

HONDA GX100KRB ENGINE — CARBURETOR ASSY.

CARBURETOR ASSY.

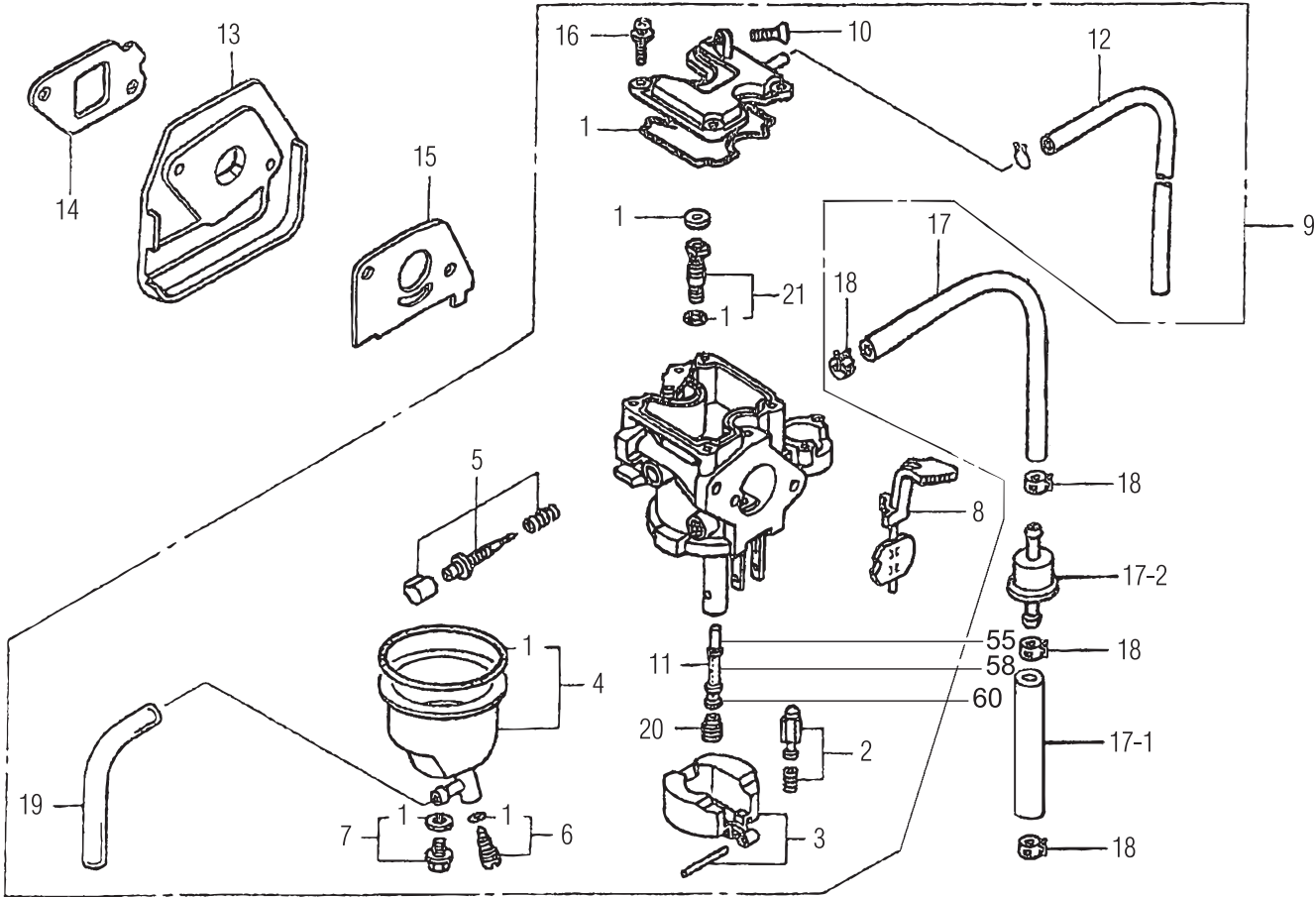

HONDA GX100KRB ENGINE — CARBURETOR ASSY.

CARBURETOR ASSY.

<u>NO.</u>	<u>PART NO.</u>	<u>PART NAME</u>	<u>QTY.</u>	<u>REMARKS</u>
1*%	16010Z0DV21	GASKET SET	1	
2*%	16011ZE0005	FLOAT VALVE SET	1	
3*%	16013ZG0811	FLOAT SET	1	
4*	16015ZM7003	FLOAT CHAMBER SET	1	S/N 1144521 BF33DA
4%	16015Z0DV21	FLOAT CHAMBER SET	1	S/N 1144522 AND ABOVE BF33DB
5*%	16016Z0DV21	SCREW SET	1	
6*%	16024ZB9005	DRAIN SCREW SET	1	
7*	16028ZG0811	SCREW SET	1	S/N 1144521 BF33DA
7%	16028ZW6611	SCREW SET	1	S/N 114522 AND ABOVE BF33DB
8*%	16044Z0DV21	LEVER SET, CHOKE	1	
9	16100Z0DV21	CARBURETOR ASSY. (BF33D A) ..	1	INCLUDES ITEMS W/ *
9	16100Z0DV22	CARBURETOR ASSY. (BF33D B) ..	1	INCLUDES ITEMS W/ %
10*%	1624ZE0005	SCREW, THROTTLE STOP	1	
11*%	16166Z0D003	MAIN NOZZLE	1	
12*%	16199Z0DV21	TUBE, VENT	1	
13	16211Z0D000	INSULATOR, CARBURETOR	1	
14	16212Z0DV20	PACKING, INSULATOR	1	
15	16221ZG0801	PACKING, CARBURETOR	1	
16*%	938920401218	SCREW 4X12	1	
17	950014527050	FUEL HOSE 4.5X270	1	S/N 1144521
17	950014521050	FUEL HOSE 4.5X210	1	S/N 1144522 AND ABOVE
17-1	950014508050	FUEL HOSE 4.5X80	1	S/N 1144522 AND ABOVE
17-2	16910GB2005	FUEL FILTER CP	1	S/N 1144522 AND ABOVE
18	950024085008	CRAMP, TUBE D8.5	1	
19*%	950030501031	TUBE, VINYL 3.5X6.5X100	1	
20*%	9910ZG00600	MAIN JET #60	1	
21*%	99204ZE00350	PILOT JET SET #35	1	
55	99101ZG00550	JET HIGH ALTITUDE	1	0 - 5,000 FT.
58	99101ZG00580	JET HIGH ALTITUDE	1	6,000 - 9,000 FT.
60	99101ZG00600	JET HIGH ALTITUDE	1	9,000 FT. AND ABOVE

HONDA GX100KRB ENGINE — AIR CLEANER ASSY.

AIR CLEANER ASSY.

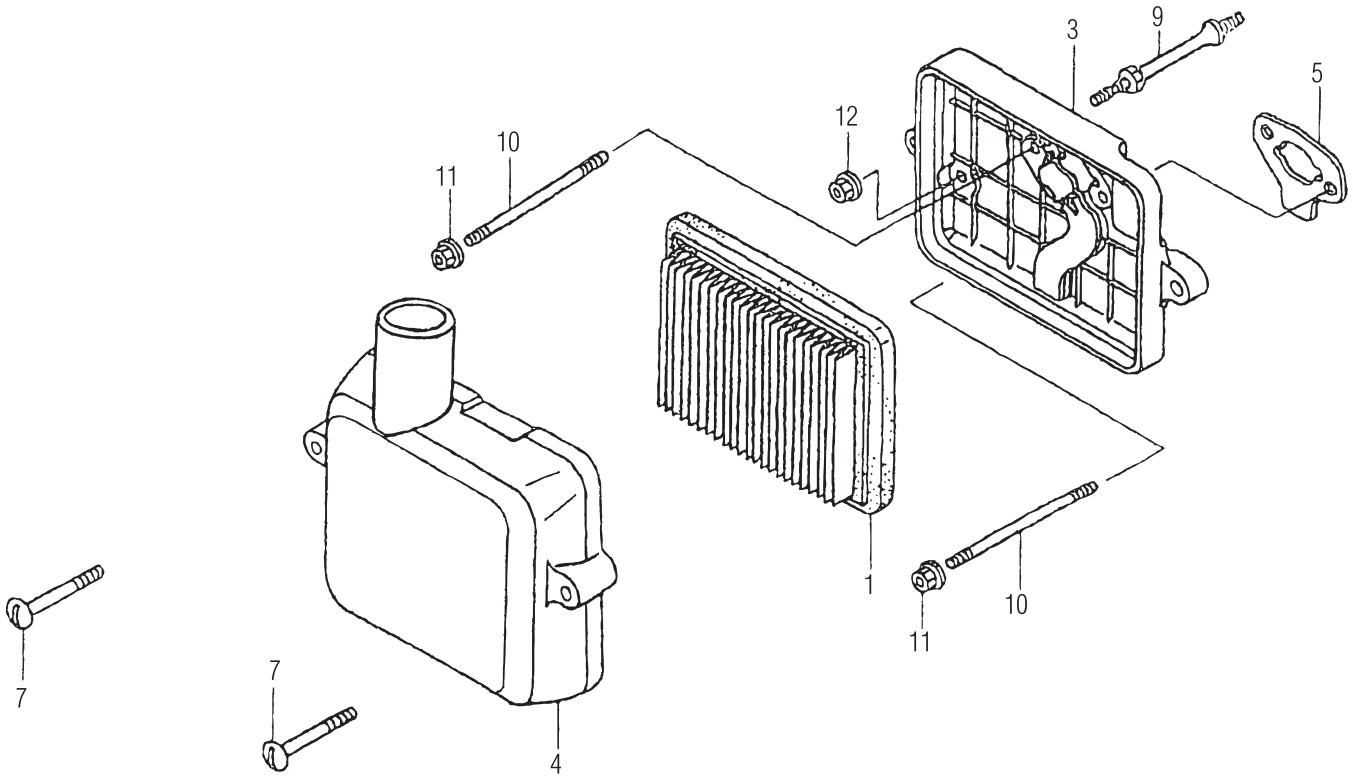

HONDA GX100KRB ENGINE — AIR CLEANER ASSY.

AIR CLEANER ASSY.

<u>NO.</u>	<u>PART NO.</u>	<u>PART NAME</u>	<u>QTY.</u>	<u>REMARKS</u>
1	17200ZL8003	CLEANER ELEMENT	1	
3	17220Z0DV20	CASE COMP., AIR CLEANER	1	
4	17231Z0DV60	COVER, AIR CLEANER.....	1	S/N 1144521
4	17231Z0DV61	COVER, AIR CLEANER.....	1	S/N 1144522 AND ABOVE
5	17228Z0DV21	PACKING, AIR CLEANER	1	
7	90011Z0D000	BOLT, AIR CLEANER COVER	2	
9	90041Z0DV20	STUD BOLT	1	
10	90042Z0DV20	STUD BOLT 5X75	2	
11	9405005000	FLANGE NUT 5MM	2	
12	9405006000	FLANGE NUT 6MM	1	

HONDA GX100KRB ENGINE — MUFFLER ASSY.

MUFFLER ASSY.

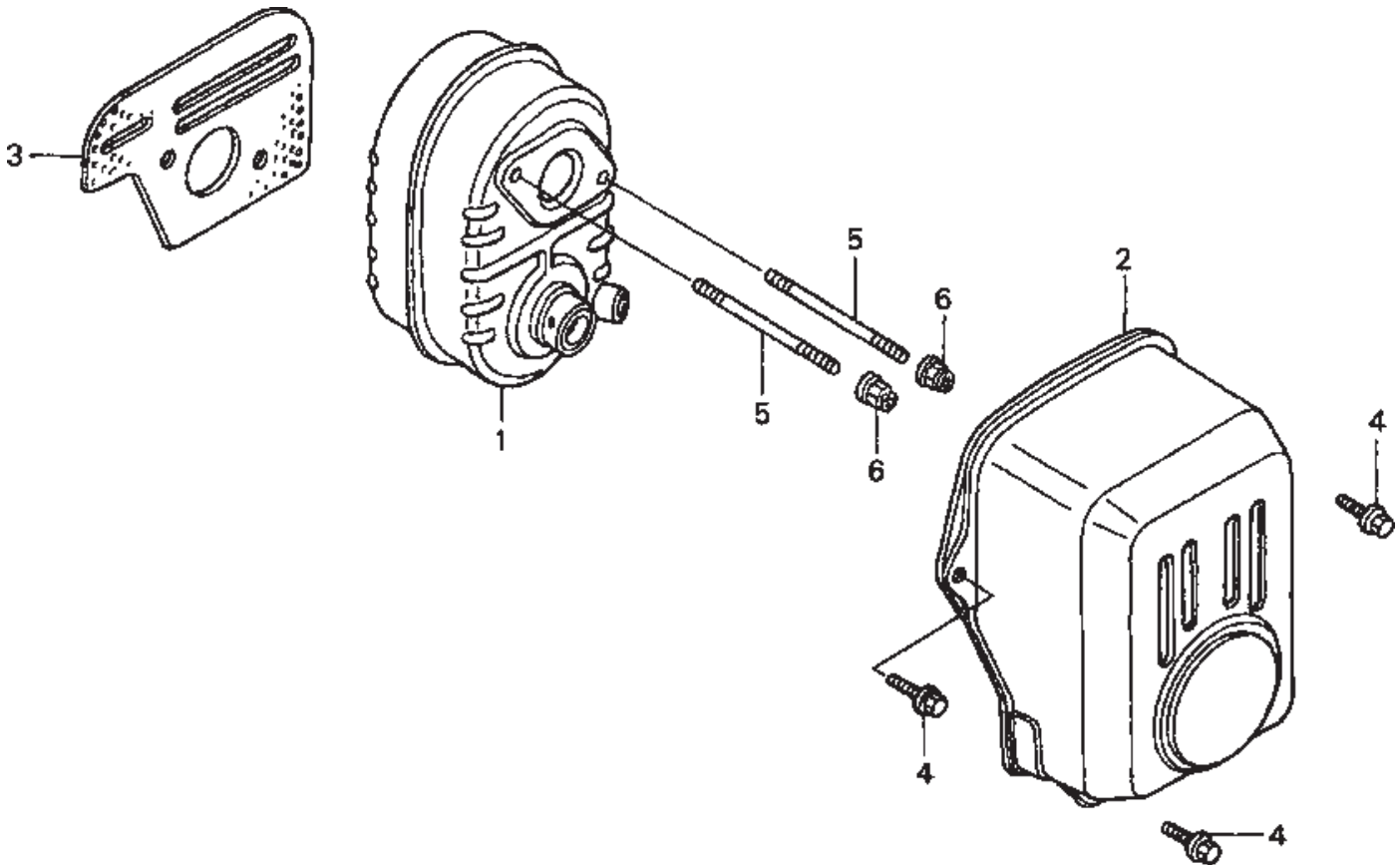

HONDA GX100KRB ENGINE — MUFFLER ASSY.

MUFFLER ASSY.

<u>NO.</u>	<u>PART NO.</u>	<u>PART NAME</u>	<u>QTY.</u>	<u>REMARKS</u>
1	18310Z0DV20	MUFFLER COMP.	1	
2	18321Z0DV20	MUFFLER PROTECTOR	1	
3	18381Z0D000	GASKET, MUFFLER	1	
4	90014952000	VOLT, FLANGE 6X14 (CT200)	3	
5	90048Z0DV00	STUD BOLT 5X78	2	
6	90343ZE6000	NUT, SELF-LOCK 6MM	2	

HONDA GX100KRB ENGINE — FLYWHEEL IGNITION ASSY.

FLYWHEEL IGNITION ASSY.

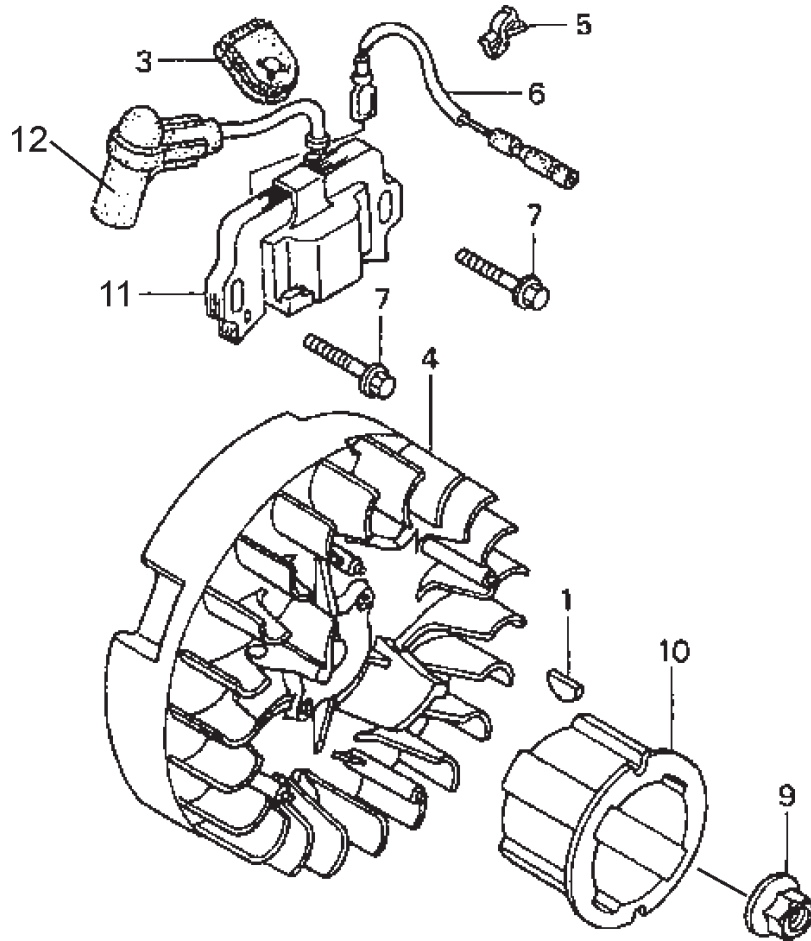

HONDA GX100KRB ENGINE — FLYWHEEL IGNITION ASSY.

FLYWHEEL IGNITION ASSY.

<u>NO.</u>	<u>PART NO.</u>	<u>PART NAME</u>	<u>QTY.</u>	<u>REMARKS</u>
1	13331ZM7000	WOODRUFF KEY 25X18	1	
3	30564ZA5000	GROMMET, CORD	1	
4	31110Z0D003	FLYWHEEL COMP.	1	
5	30701883000	CLIP, HIGH TENSION CORD	1	
6	32195Z0D000	CORD, STOP SWITCH	1	
7	90022888010	FLANGE BOLT 6X20	2	
9	9405012000	FLANGE NUT M12	1	
10	28451Z0DV02	STARTER PULLEY	1	
11	30500Z0DV01	IGNITION COIL ASSY	1	INCLUDES ITEMS W/ *
12*	30700Z0DV01	TERMINAL ASSY.	1	

HONDA GX100KRB ENGINE — CONTROL ASSY.

CONTROL ASSY.

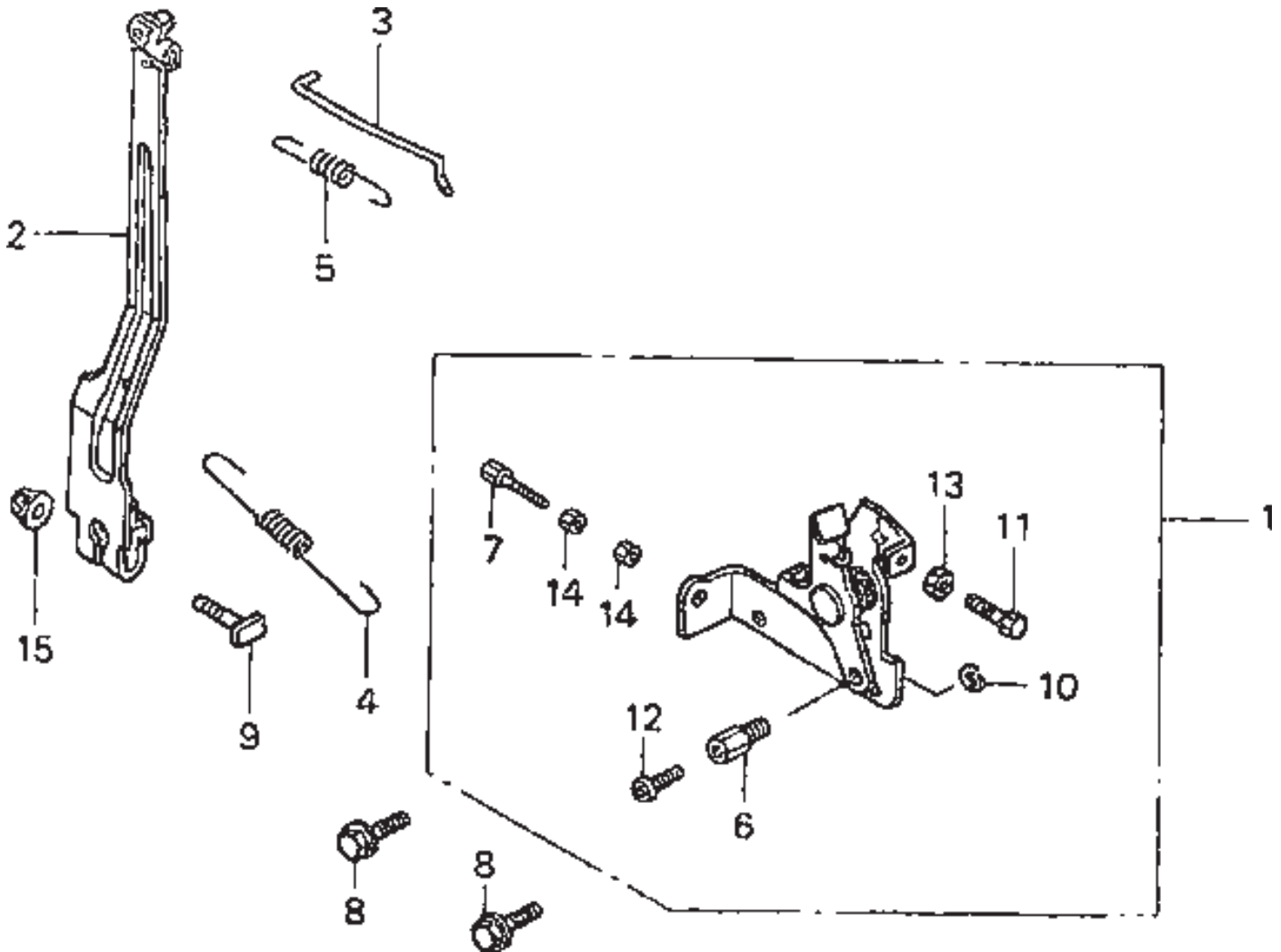

HONDA GX100KRB ENGINE — CONTROL ASSY.

CONTROL ASSY.

<u>NO.</u>	<u>PART NO.</u>	<u>PART NAME</u>	<u>QTY.</u>	<u>REMARKS</u>
1	16500ZG0V90	CONTROL ASSY	1	INCLUDES ITEMS W/ *
2	16550Z0DV20	GOVERNOR ARM	1	
3	16555Z0DV20	GOVERNOR ROD	1	
4	16561Z0DV20	GOVERNOR SPRING	1	
5	16562Z0DV20	SPRING, THROTTLE	1	
6*	16594883010	HOLDER, WIRE	1	
7*	54717ZG0S00	ADJUSTING BOLT	1	
8	90014952000	VOLT, FLANGE 6X14 (CT200)	2	
9	90015ZE5010	BOLT, GOVERNOR ARM	1	
10*	90605230000	CIR CLIP	1	
11*	92301050200A	BOLT 5X20	1	
12*	93500040060H	SCREW 4X6	1	
13*	94001050000S	NUT 5MM	1	
14*	94002060000S	NUT 6MM	2	
15	94050060000	FLANGE NUT 6MM	1	

HONDA GX100KRB ENGINE — LABELS ASSY.

LABELS ASSY.

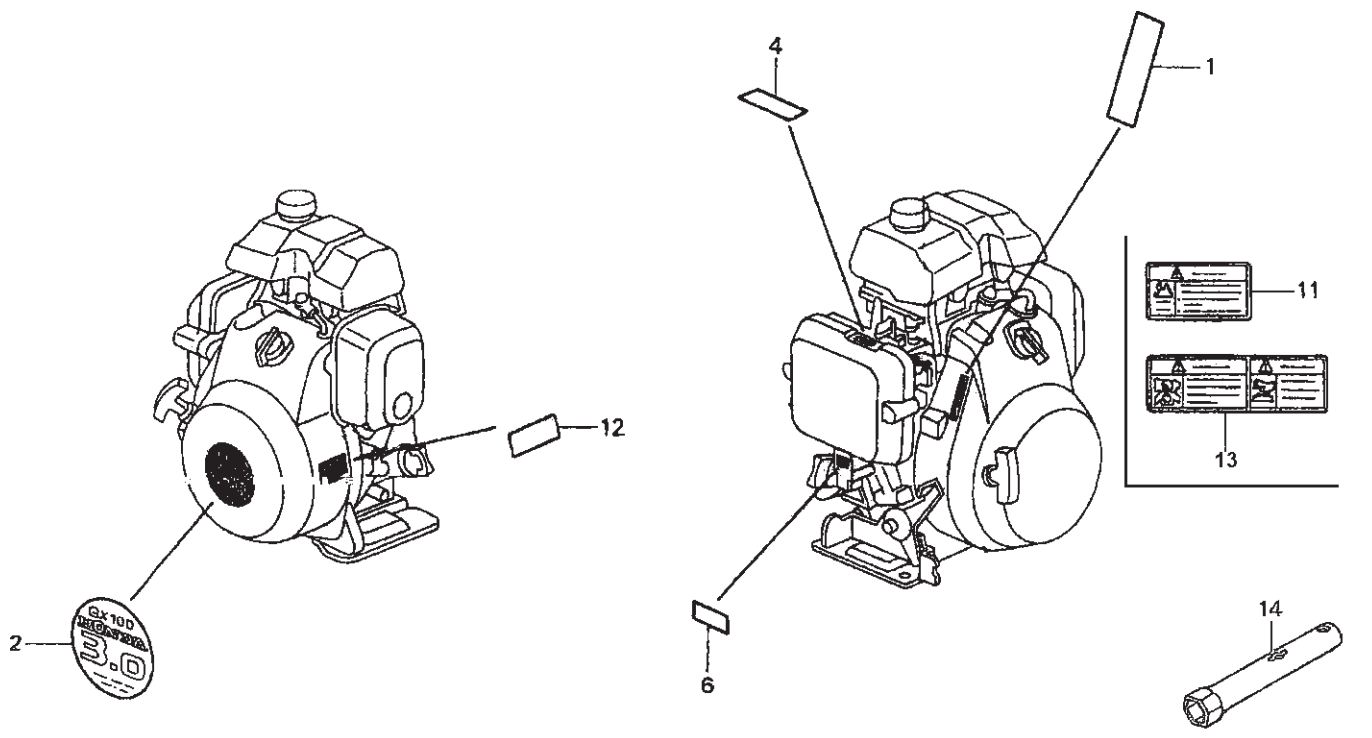

HONDA GX100KRB ENGINE — LABELS ASSY.

LABELS ASSY.

<u>NO.</u>	<u>PART NO.</u>	<u>PART NAME</u>	<u>QTY.</u>	<u>REMARKS</u>
1	87135ZE2020	LABEL (E-SPEC)	1	
2	87521Z0DV01	LABEL, TRADE MARK	1	
4	87528Z0D000	MARK, CHOKE	1	
6	87601Z0DU10	MARK, TYPE (KRB4)	1	
6	87601Z0DV50	MARK, TYPE (KRB)	1	
11	87106737J00	LABEL, FUEL WARNING	1	
12	87150ZH8000	LABEL, CAUTION	1	
13	87526ZH8000	LABEL, COMBINATION	1	
14	89216130690	WRENCH, SPARK PLUG	1	