

# **OPERATION AND PARTS MANUAL**

# **STOW**

A DIVISION OF MULTIQUIP INC.

## **MODEL MS-63 PLASTER AND MORTAR MIXER (GASOLINE ENGINE/ELECTRIC MOTOR)**

Revision #5 (03/26/10)

**THIS MANUAL MUST ACCOMPANY THE EQUIPMENT AT ALL TIMES.**

# STOW MS-63 MIXER — SUGGESTED SPARE PARTS

## MS-63P/S PLASTER AND MORTAR MIXER 1 TO 3 UNITS WITH HONDA GX160K1QMX2HX2 AND GX240K1HA2 ENGINES

Qty...	P/N	Description
6	491107	V-BELT A32, HONDA ENGINE (5.5 HP)
6	505834	V-BELT A36, HONDA ENGINE (8.0 HP)
6	491112	V-BELT A40, ELECTRIC MOTOR
2	EM914288	OIL SEAL, AXLE
4	EM903113	BEARING, CONE, AXLE
4	EM903112	BEARING, CUP, AXLE
2	20654-001	SEAL, PADDLE SHAFT (BLACK)
2	530029	RING, RETENTION
2	20104-002	SEAL, SHAFT URETHANE (YELLOW)
3	17210ZE1517	ELEMENT, AIR CLEANER (5.5 HP)
3	17210ZE2515	ELEMENT, AIR CLEANER (8.0 HP)
3	9807956846	SPARK PLUG, BPR6ES, NGK
3	9807956855	SPARK PLUG, W20EPR-U, DENSO
1	28462ZH8003	ROPE, RECOIL STARTER (5.5 HP)
1	28462ZE2W11	ROPE, RECOIL STARTER (8.0 HP)
1	17620ZH7023	CAP, FUEL TANK
2	25647-502	KIT, WIPER BLADES (STEEL DRUM)

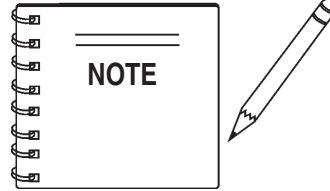

Part numbers on this Suggested Spare Parts List may supercede/replace the P/ N's shown in the test pages of this manual.

# STOW MS-63 MIXER — NAMEPLATE AND DECALS

## NAMEPLATE AND DECALS

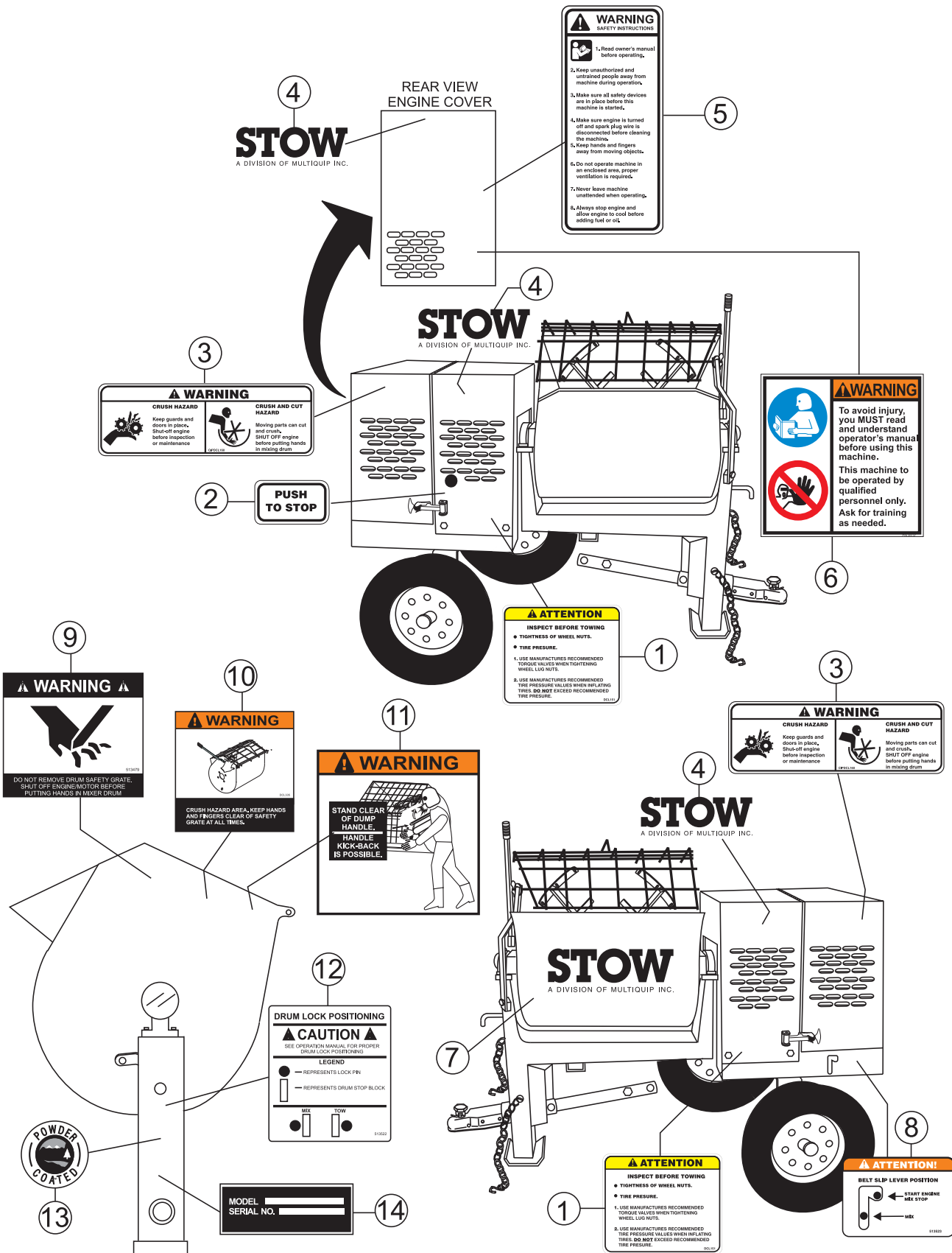

# STOW MS-63 MIXER — NAMEPLATE AND DECALS

## NAMEPLATE AND DECALS

<u>NO</u>	<u>PART NO</u>	<u>PART NAME</u>	<u>QTY.</u>	<u>REMARKS</u>
1	DCL151	DECAL, TOWING INSTRUCTIONS	2	
2	EM948630	DECAL, PUSH TO STOP	1	
3	CIPDCL160	DECAL, CRUSH WARNING	2	
4	510164	DECAL, STOW LOGO (SMALL)	3	
5	504713	DECAL, SAFETY INSTRUCTIONS	1	
6	35137	DECAL, WARNING READ	1	
7	512527	DECAL, STOW LOGO (LARGE)	3	
8	513523	DECAL, BELT SLIP	1	
9	513479	DECAL, WARNING SAFETY GRATE	1	
10	DCL335	DECAL, CRUSH WARNING SAFETY GRATE	1	
11	DCL280	DECAL, WARNING DUMP HANDLE	1	
12	513522	DECAL, DRUM LOCK	1	
13	13118	DECAL, POWDER COATED	1	
14		NAMEPLATE .....	1	..... CONTACT PARTS DEPT.

SEE OPERATION AND SAFETY DECALS PAGE.

# STOW MS-63 MIXER — FRAME ASSY.

## FRAME ASSY.

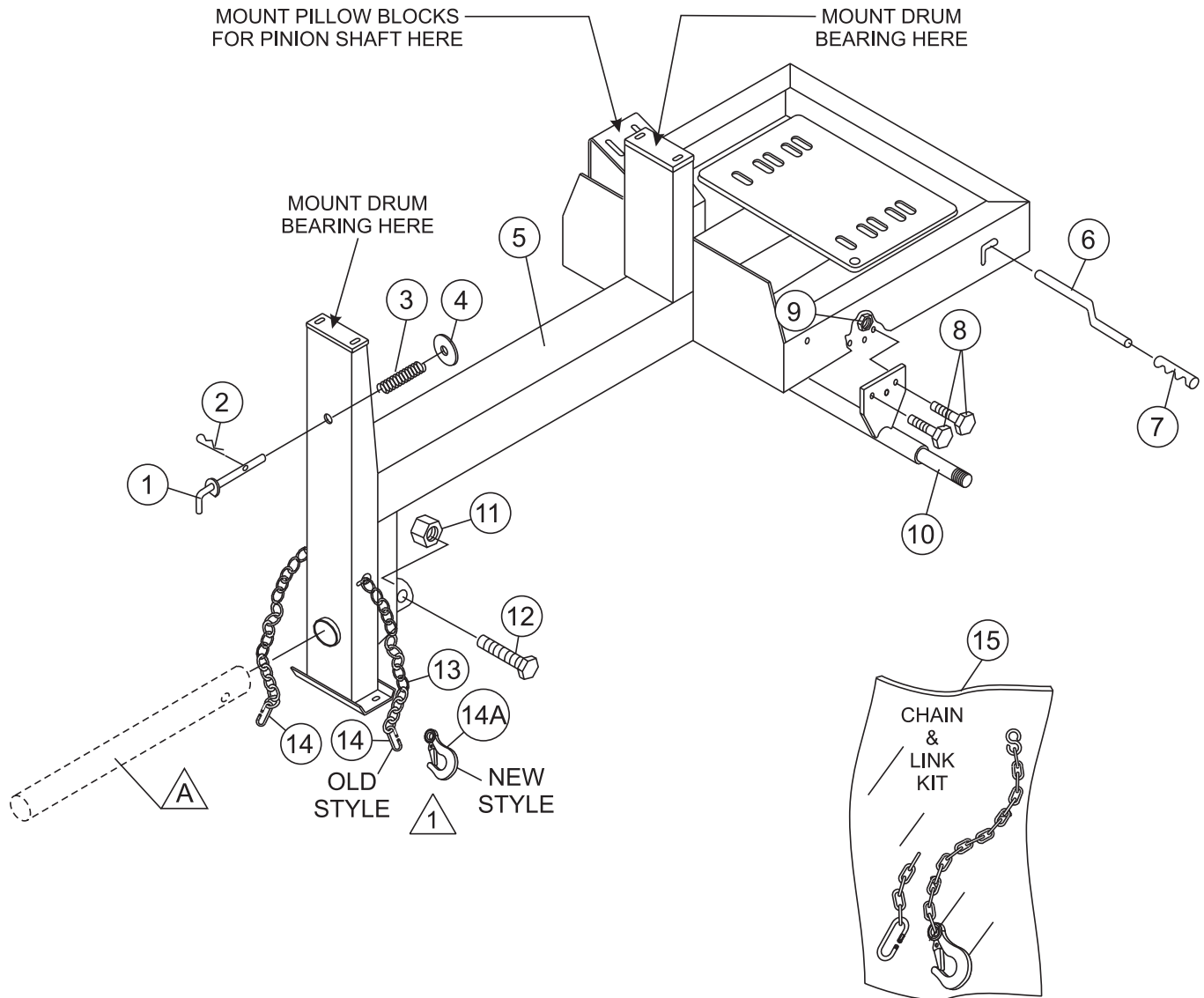

### **A** OPTIONAL TOW BARS

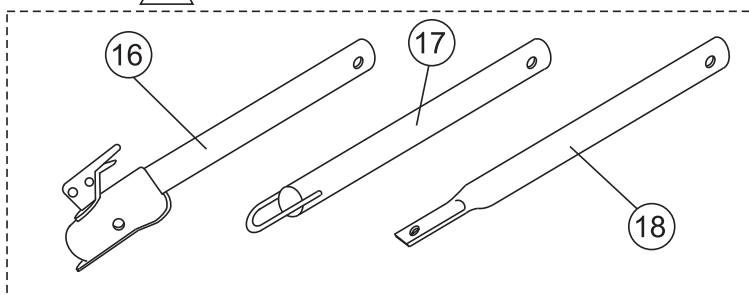

**1**

Quantity of item 14, Connector Link, changed from 2 to 1 in January 2006. Item 14A, Clevis Safety Hook, replaces discontinued Connector Link.

# STOW MS-63 MIXER — FRAME ASSY.

## FRAME ASSY.

<u>NO.</u>	<u>PART NO.</u>	<u>PART NAME</u>	<u>QTY.</u>	<u>REMARKS</u>
1	514842	LOCK, PIN	1	
2	491692	COTTER PIN	1	
3	530023	SPRING LOCKING PIN	1	
4	507444	WASHER, FLAT 3/4"	1	
5	514834	MAIN FRAME	1	
6	530013	CLUTCH HANDLE LEVER	1	
7	20278-001	CLUTCH HANDLE GRIP	1	
8	EM963692	BOLT 1/2" UNC 1-1/2"	6	
9	492584	NUT, LOCK 1/2"	6	
10	514802Y	AXLE, UNIVERSAL	1	
11	10176	LOCK NUT 1/2" NC	1	
12	EM124	BOLT 1/2"-13 X 4 G5	1	
13*		SAFETY CHAIN	1	
14*	01004	CONNECTOR LINK .....	2	BEFORE JANUARY 2006
14*	01004	CONNECTOR LINK .....	1	AFTER JANUARY 2006
14A*	516580	CLEVIS SAFETY HOOK .....	1	AFTER JANUARY 2006
15	13363KIT	CHAIN AND LINK KIT .....	1	INCLUDES ITEMS W/*
16	HBC-1	BALL HITCH 2-INCH .....	1	CONTACT UNIT SALES
17	HLC-1	LOOP HITCH .....	1	CONTACT UNIT SALES
18	HPC-1	PIN HITCH 1-INCH .....	1	CONTACT UNIT SALES

# STOW MS-63 MIXER — PADDLE SHAFT ASSY.

## PADDLE SHAFT ASSY.

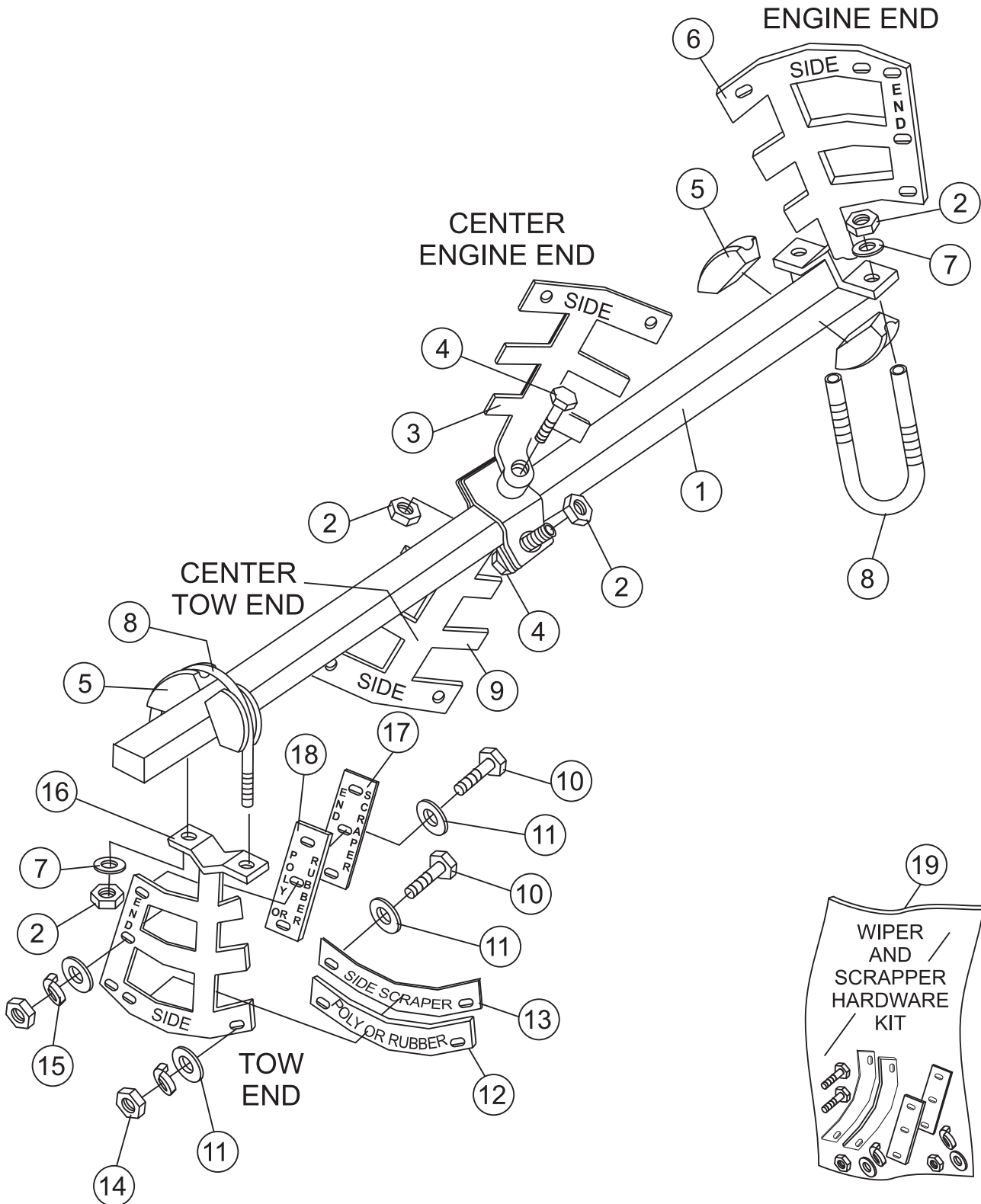

# STOW MS-63 MIXER — PADDLE SHAFT ASSY.

PADDLE SHAFT ASSY.

<u>NO.</u>	<u>PART NO.</u>	<u>PART NAME</u>	<u>QTY.</u>	<u>REMARKS</u>
1	514752	PADDLE SHAFT	1	
2	492584	NUT, LOCK 1/2"	6	
3	530140C	PADDLE ARM, CENTER ENGINE END	1	
4	492400	BOLT, 1/2 " X 3-1/2" G5	2	
5	EM200292	INSERT, PADDLE ARM	4	
6	530141	PADDLE ARM, ENGINE END	1	
7	504322	WASHER, FLAT 1/2"	6	
8	EM200297	U-BOLT, END PADDLES	2	
9	530143	PADDLE ARM, CENTER TOW END	1	
10	505196	SCREW, 3/8" NC X 1-1/2 " G5	18	
11	492598	WASHER, FLAT 3/8"	28	
12*	25667-001	BLADE, SIDE, RUBBER	4	
13	25668-001	BLADE, SIDE, SCRAPPER	4	
14	492554	NUT, HEX 3/8" NC G5	14	
15	492624	WASHER, LOCK 3/8"	14	
16	530142C	PADDLE ARM, TOW END	1	
17	33074-001	BLADE ,SCRAPPER END	2	
18*	33017-001	BLADE, RUBBER END	2	
19	25647-502	KIT, WIPERS .....	1	INCLUDES ITEMS W/*



# STOW MS-63 MIXER — STEEL DRUM ASSY.

## STEEL DRUM ASSY.

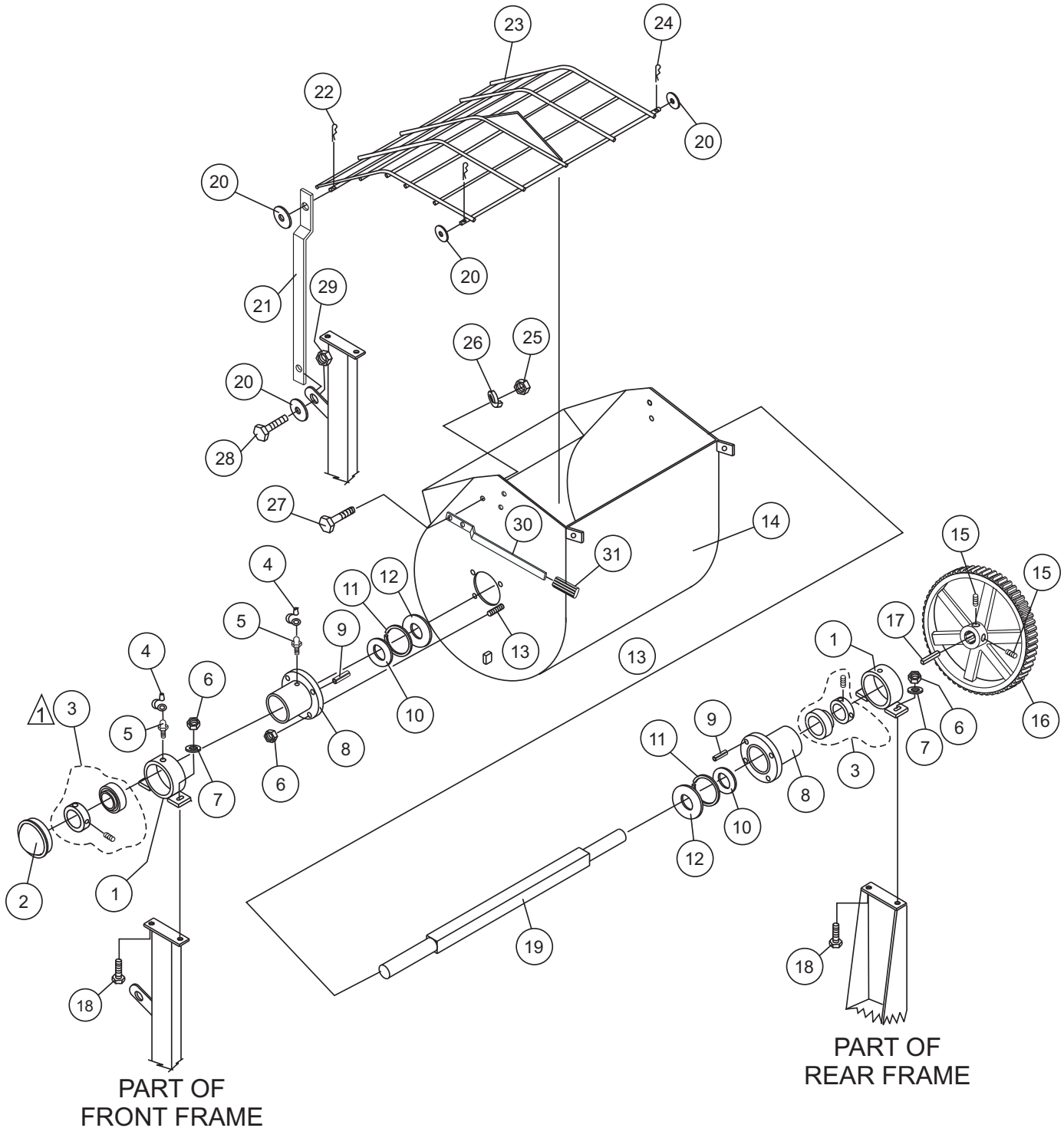

### NOTES:

- 1 SET SCREWS AND BEARING COLLAR ARE INCLUDED WITH BEARING AND CANNOT BE PURCHASED SEPARATELY.

# STOW MS-63 MIXER — STEEL DRUM ASSY.

## STEEL DRUM ASSY.

<u>NO.</u>	<u>PART NO.</u>	<u>PART NAME</u>	<u>QTY.</u>	<u>REMARKS</u>
1	530028Y	DRUM BEARING BRACKET	2	
2	3249Y	CAP, DUST	1	
3	20561-001	BEARING SEALED .....	2 .....	SET SCREWS AND BEARING COLLAR CANNOT BE PURCHASED SEPARATELY.
4	491008	CAP, GREASE FITTING	2	
5	EM916019	FITTING, GREASE	2	
6	EM969013	NUT, LOCK 3/8"	12	
7	3019092	WASHER, FLAT 3/8"	4	
8	514778Y	TRUNNION HUB	2	
9	513453	ROLL PIN 3/16" X 3/4"	2	
10	20654-001	SEAL, SHAFT (BLACK)	2	
11	530029	RING, RETENTION	2	
12	20104-002	SEAL, SHAFT URETHANE (YELLOW)	2	
13	513452	BOLT 3/8" NC X 1/4" G5	8	
14	515009	DRUM, STEEL	1	
15	492484	SET SCREW	2	
16	530043	MAIN GEAR	1	
17	500432	KEY, 3/8" X 50 MM	1	
18	17985-012	CARRIAGE BOLT 3/8-16 X 1-1/2"	4	
19	514752	SHAFT, PADDLE	1	
20	492600	WASHER, FLAT 1/2"	4	
21	515032	LIFT BAR	1	
22	EM925191	PIN, COTTER	1	
23	514962Y	GRATE	1	
24	505070	PIN, COTTER	2	
25	492556	HEX NUT 1/2" G5	2	
26	6109180	WASHER, LOCK 1/2"	2	
27	EM963692	BOLT 1/2" NC 1-1/4" G5	2	
28	492393	CAPSCREW, HHCS 1/2" NC X 1-1/4"	1	
29	492584	NUT, LOCK 1/2" NC	1	
30	EM201537Y	HANDLE DUMP	1	
31	15081	GRIP, DUMP HANDLE	1	

# STOW MS-63 MIXER — DRUM & PADDLE SHAFT COMPLETE ASSY.

DRUM AND PADDLE SHAFT COMPLETE ASSY.

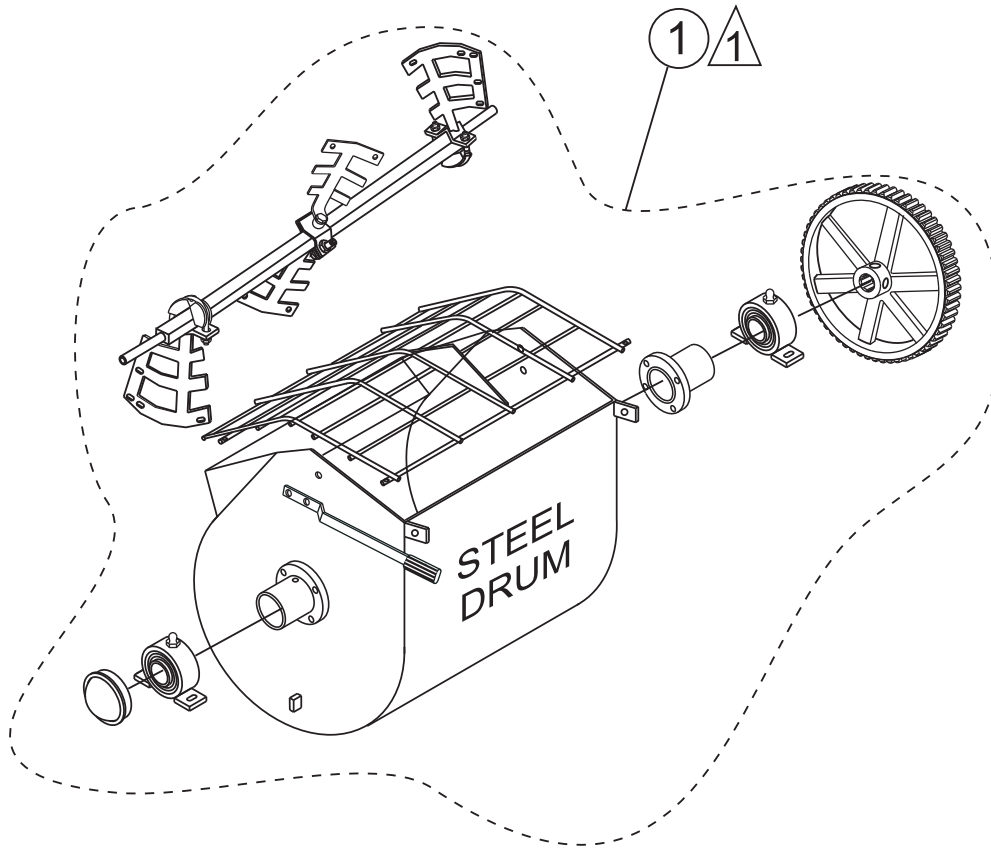

NOTES:

- △ 1 COMPLETE DRUM AND PADDLE SHAFT ASSEMBLIES ARE INCLUDED WITHIN DASHED LINES.

# STOW MS-63 MIXER — DRUM & PADDLE SHAFT COMPLETE ASSY.

## DRUM AND PADDLE SHAFT COMPLETE ASSY.

<u>NO.</u>	<u>PART NO.</u>	<u>PART NAME</u>	<u>QTY.</u>	<u>REMARKS</u>
1	516069	DRUM AND SHAFT COMPLETE ASSY. ....	1	INCLUDES ITEMS LISTED BELOW:
	530028Y	DRUM BEARING BRACKET	2	
	3249Y	CAP, DUST	1	
	20561-001	BEARING SEALED	2	
	491008	CAP, GREASE FITTING	2	
	EM916019	FITTING, GREASE	2	
	EM969013	NUT, LOCK 3/8"	12	
	3019092	WASHER, FLAT 3/8"	4	
	514778Y	TRUNNION HUB	2	
	513453	ROLL PIN 3/16" X 3/4"	2	
	20654-001	SEAL, SHAFT (BLACK)	2	
	530029	RING, RETENTION	2	
	20104-002	SEAL, SHAFT URETHANE (YELLOW)	2	
	513452	BOLT 3/8" NC X 1/4" G5	8	
	515009	DRUM, STEEL	1	
	492484	SET SCREW	2	
	530043	MAIN GEAR	1	
	500432	KEY, 3/8" X 50 MM	1	
	EM963057	CAPSCREW HHCS 3/8 X 1-1/2"	4	
	514752	SHAFT, PADDLE	1	
	492600	WASHER, FLAT 1/2"	2	
	514946	GRATE	1	
	505070	PIN, COTTER	2	
	492556	HEX NUT 1/2" G5	2	
	6109180	WASHER, LOCK 1/2"	2	
	EM963692	BOLT 1/2" UNC 1-1/2"	2	
	EM201537	HANDLE DUMP	1	
	15081	GRIP, DUMP HANDLE	1	
	514752	PADDLE SHAFT	1	
	492584	NUT, LOCK 1/2"	6	
	530142	PADDLE ARM, CENTER ENGINE END	1	
	510721	BOLT, 1/2 " X 6" G5	2	
	EM200292	INSERT, PADDLE ARM	4	
	530141	PADDLE ARM, ENGINE END	1	
	504322	WASHER, FLAT 1/2"	6	
	EM200297	U-BOLT, END PADDLES	2	
	530143	PADDLE ARM, CENTER TOW END	1	
	505196	SCREW, 3/8" NC X 1-1/2 " G5	18	
	EM923023	WASHER, FLAT 5/16"	28	
	25667-001	BLADE, SIDE, RUBBER	4	
	25668-001	BLADE, SIDE, SCRAPPER	4	
	2105164	NUT, HEX 5/16" NC G5	14	
	EM923343	WASHER, LOCK 5/15"	14	
	530140	PADDLE ARM, TOW END	1	
	33074-001	BLADE ,SCRAPPER END	2	
	33017-001	BLADE, RUBBER END	2	

# STOW MS-63 MIXER — AXLE ASSY.

AXLE ASSY.

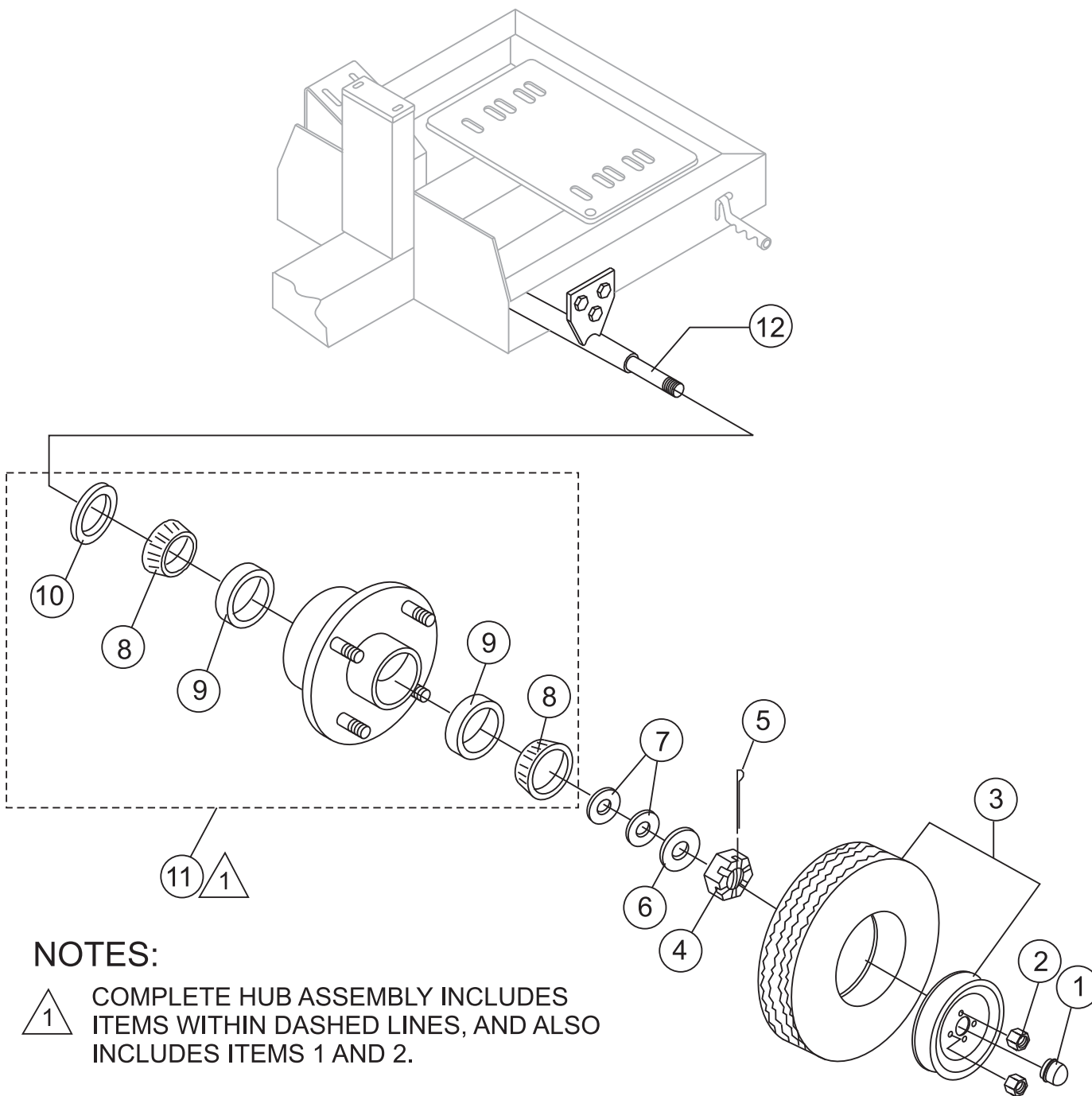

## NOTES:



COMPLETE HUB ASSEMBLY INCLUDES ITEMS WITHIN DASHED LINES, AND ALSO INCLUDES ITEMS 1 AND 2.

## STOW MS-63 MIXER — AXLE ASSY.

### AXLE ASSY.

<u>NO</u>	<u>PART NO</u>	<u>PART NAME</u>	<u>QTY.</u>	<u>REMARK</u>
1#	3469	DUST CAP	2	
2#	8115	LUG NUTS	8	
3	3005	TIRE AND RIM, CARLISE .....	2	BEFORE JANUARY 2006
3	516476	TIRE AND RIM, TOWMASTER II .....	2	AFTER JANUARY 2006
4	8164	CASTLE NUT 1"	2	
5	491688	COTTER PIN 1/8" X 1-1/2'	2	
6	EM511159	WASHER, FLAT, .087" THICKNESS	2	
7	EM501299	WASHER, FLAT, .135" THICKNESS	1	
8#	EM903113	BEARING CONE	4	
9#	EM903012	BEARING CUP	4	
10#	EM914288	OIL SEAL	2	
11	EM941306	HUB ASSY., 4-BOLT .....	2	INCLUDES ITEMS W/#
12	514802Y	AXLE, UNIVERSAL	1	

# STOW MS-63 MIXER — ENGINE ASSY.

ENGINE ASSY.

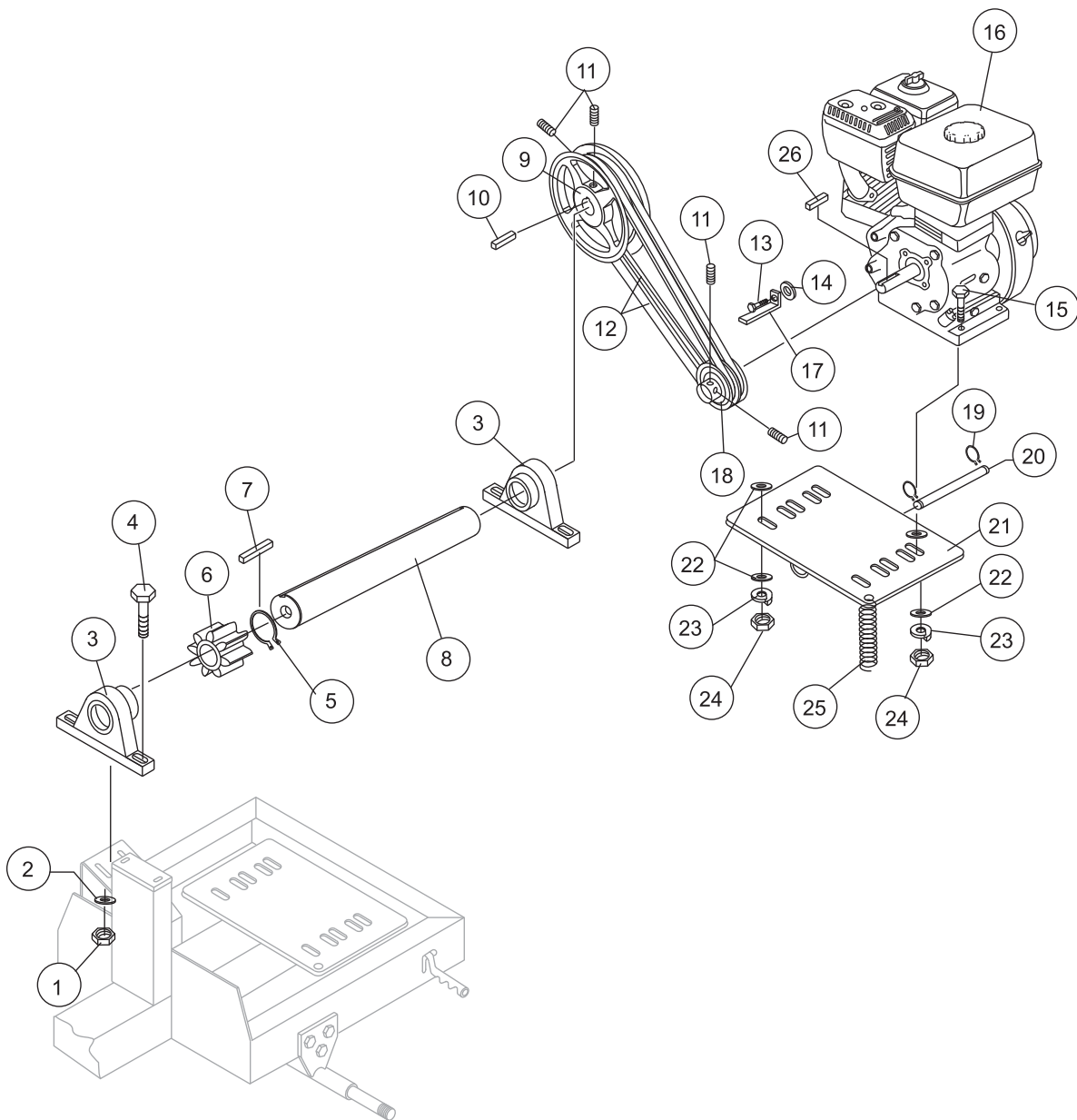

# STOW MS-63 MIXER — ENGINE ASSY.

## ENGINE ASSY.

<u>NO</u>	<u>PART NO</u>	<u>PART NAME</u>	<u>QTY.</u>	<u>REMARKS</u>
1	492583	NUT 3/8" NC G5	4	
2	506488	FLAT WASHER 3/8	8	
3	EM905016	PILLOW BLOCK BEARING	2	
4	492378	BOLT 3/8" NC X 1-3/4" G5	4	
5	490957	RING, RETAINER	1	
6	513868	PINION GEAR	1	
7	500214	KEY, 1/4" X 30 MM	1	
8	502226	PINION SHAFT	1	
9	492077	PULLEY (LARGE)	1	
10	505084	KEY, 1/4" X 55 MM	1	
11	492467	SET SCREW, 5/16" NC 3/8"	4	
12	491107	V-BELT, A-32 .....	2	HONDA 5.5 HP
12	07055-034	V-BELT, A-34 .....	2	HONDA 8.0 HP
13	503117	BOLT, 3/8" NC X 3" G5	1	
14	508344	WASHER, FLAT 5/16"	1	
15	492367	BOLT 5/16" NC X 1-3/4" G5 .....	4	HONDA 5.5 HP
15	492378	BOLT 3/8" NC X 1-3/4" G5 .....	4	HONDA 8.0 HP
16	GX160K1QMX2HX2	ENGINE, HONDA .....	1	HONDA 5.5 HP
16	GX240K1HA2	ENGINE, HONDA .....	1	HONDA 8.0 HP
17	514985	BELT RETAINER BAR	1	
18	492055	PULLEY, (SMALL) .....	1	HONDA 5.5 HP
18	505205	PULLEY, (SMALL) .....	1	HONDA 8.0 HP
19	604445	RING, RETENTION	2	
20	530454	SHAFT, ENGINE MOUNT	1	
21	530019	ENGINE MOUNTING PLATE	1	
22	492597	WASHER, FLAT 5/16"	6	
22	492598	WASHER, FLAT 3/8"	6	
23	492623	WASHER, LOCK 5/16"	4	
23	492624	WASHER, LOCK 3/8"	4	
24	492553	NUT, HEX 5/16"	4	
24	492554	NUT, HEX 3/8"	4	
25	EM102014	SPRING, EXTENSION	1	
26	501019	SQ. KEY 3/16" X 45 MM .....	1	HONDA 5.5 HP
26	90745ZE2600	SQ. KEY 6.3 X 6.3 X 43 MM .....	1	HONDA 8.0 HP



# STOW MS-63 MIXER — ELECTRIC MOTOR ASSY.

ELECTRIC MOTOR ASSY.

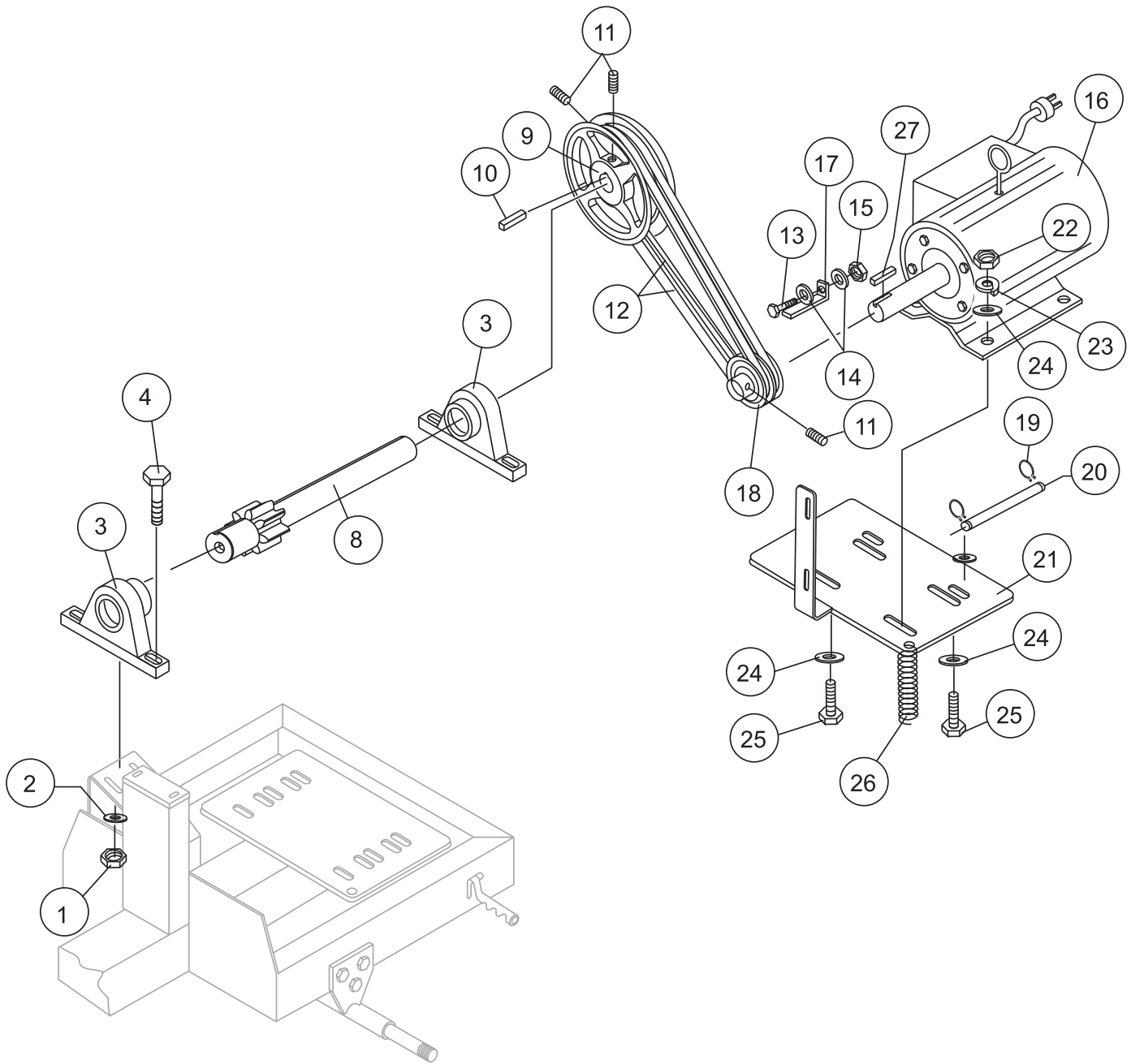

## STOW MS-63 MIXER — ELECTRIC MOTOR ASSY.

### ELECTRIC MOTOR ASSY.

<u>NO</u>	<u>PART NO</u>	<u>PART NAME</u>	<u>QTY.</u>	<u>REMARKS</u>
1	492583	NUT 3/8" NC G5	4	
2	506488	FLAT WASHER 3/8	8	
3	EM905016	PILLOW BLOCK BEARING	2	
4	492378	BOLT 3/8" NC X 1-3/4" G5	4	
8	20216-001	PINION SHAFT	1	
9	20061-001	PULLEY (LARGE)	1	
10	500275	KEY, 1/4" X 40 MM	1	
11	492467	SET SCREW, 5/16" NC 3/8"	3	
12	491112	V-BELT, A-40	2	
13	503117	CAP SCREW 5/16"-18X 1"	1	
14	492598	WASHER, FLAT 3/8"	2	
15	492582	NUT, NYLON 5/16"-18	1	
16	35L229S302	ELECTRIC MOTOR 1.5 HP	1	
17	514985	BELT RETAINER BAR	1	
18	502213	PULLEY, (SMALL)	1	
19	604445	RING, RETENTION	2	
20	530454	SHAFT, ENGINE MOUNT	1	
21	530089	ELECTRIC MOTOR MOUNTING PLATE	1	
22	2105164	NUT, HEX 5/16" NC	4	
23	492623	WASHER, LOCK 5/16"	4	
24	EM923023	WASHER, FLAT 5/16"	8	
25	492378	BOLT 3/8" NC X 1-3/4" G5	4	
26	530024	SPRING, EXTENSION	1	
27	500169	KEY, 3/16" X 50 MM	1	

# STOW MS-63 MIXER — CABINET ASSY.

CABINET ASSY.

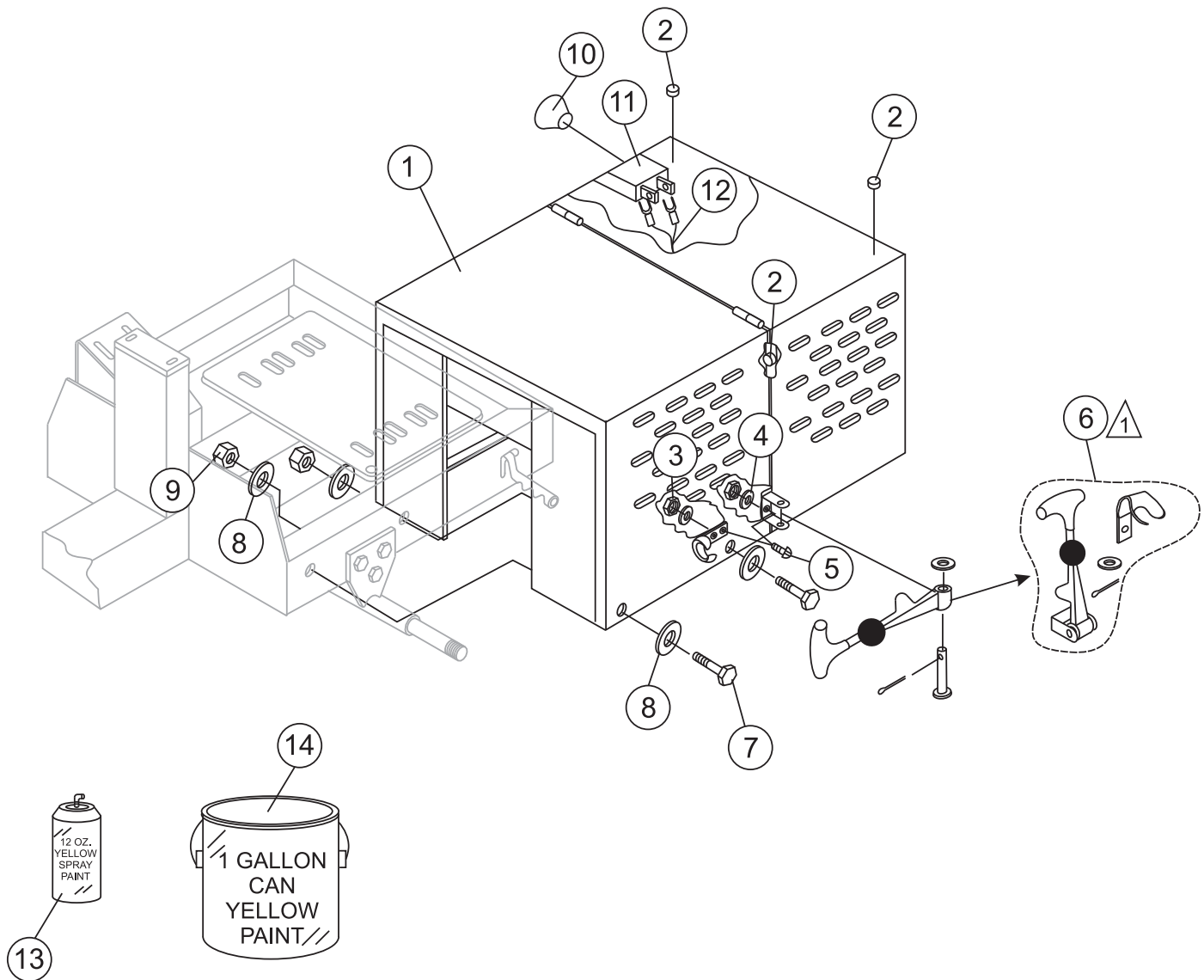

**NOTES:**



COMPLETE LATCH ASSEMBLY  
INCLUDES ITEMS WITHIN DASHED  
LINES. ITEMS CANNOT BE PURCHASED  
SEPARATELY.

# STOW MS-63 MIXER — CABINET ASSY.

## CABINET ASSY.

<u>NO</u>	<u>PART NO</u>	<u>PART NAME</u>	<u>QTY.</u>	<u>REMARKS</u>
1	515014	CABINET, ENGINE W/DECALS .....	1 .....	INCLUDES ITEMS W/*
2	490202	RUBBER PROTECTOR	4	
3	13287	LOCK NUT 8-32 .....	6 .....	REPLACEMENT PART ONLY
4	2203	WASHER, FLAT #10 .....	6 .....	REPLACEMENT PART ONLY
5	1307	SCREW RHMS 8-32 X 1/2" .....	6 .....	REPLACEMENT PART ONLY
6*	491010	LATCH ASSY., COMPLETE	2	
7	492375	BOLT 3/8" NC X 1" G5	4	
8	492598	WASHER, FLAT 3/8"	4	
9	492583	NUT 3/8" NC G5	4	
10	29174-001	KNOB, MUSHROOM	1	
11	29173-001	SWITCH, PUSH-PULL	1	
12	504135C	WIRE HARNESS	1	
13	RAL1003S	PAINT, SPRAY CAN 12 OZ., YELLOW	AR	
14	RAL1003G	PAINT, GALLON CAN, YELLOW	AR	

# HONDA GX160K1QMX2HX2 ENGINE — AIR CLEANER ASSY.

AIR CLEANER ASSY.

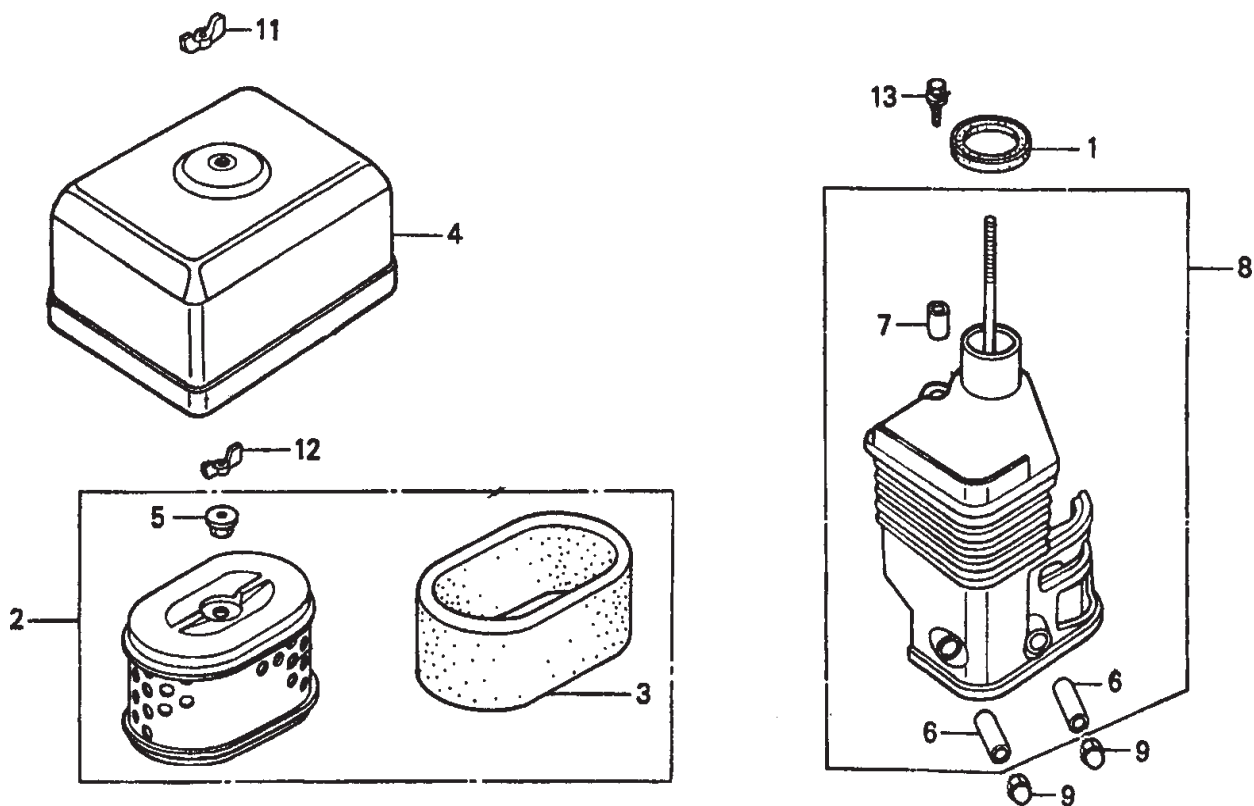

# HONDA GX160K1QMX2HX2 ENGINE — AIR CLEANER ASSY.

## AIR CLEANER ASSY.

<u>NO</u>	<u>PART NO</u>	<u>PART NAME</u>	<u>QTY.</u>	<u>REMARKS</u>
1	16271ZE1000	GASKET ELBOW	1	
2	17210ZE1505	AIR CLEANER ELEMENT DUAL .....	1	INCLUDES ITEMS W/#
3#	17218ZE1821	FILTER OUTER	1	
4	17230ZE1820	COVER AIR CLEANER DUAL	1	
5#	17232891000	GROMMET, AIR CLEANER	1	
6*	17238ZE7010	COLLAR, AIR CLEANER	1	
7*	17239ZE1000	COLLAR B, AIR CLEANER	1	
8	17410ZE1020	ELBOW COMP. AIR CLEANER .....	1	INCLUDES ITEMS W/*
9	90201415000	NUT CAP 6MM	2	
11	90325044000	NUT WING TOOL BOX SETTING	1	
12	90325044000	NUT WING TOOL BOX SETTING	1	
13	957010602000	BOLT FLANGE 6 x 20	1	



# HONDA GX160K1QMX2HX2 ENGINE — CAMSHAFT ASSY.

## CAMSHAFT ASSY.

<u>NO</u>	<u>PART NO</u>	<u>PART NAME</u>	<u>QTY.</u>	<u>REMARKS</u>
1	14100ZE1812	CAMSHAFT ASSY. ....	1	INCLUDES ITEMS W/*
2	14410ZE1010	ROD, PUSH	2	
3	14431ZE1000	ARM, VALVE ROCKER	2	
4	14441ZE1010	LIFTER, VALVE	2	
5	14451ZE1013	PIVOT, ROCKER ARM	2	
6*	14568ZE1000	SPRING, WEIGHT RETURN	1	
7	14711ZF1000	VALVE, IN.	1	
8	14721ZF1000	VALVE, EX.	1	
9	14751ZF1000	SPRING, VALVE	2	
10	14771ZE1000	RETAINER, IN. VALVE SPRING	1	
11	14773ZE1000	RETAINER, EX. VALVE SPRING	1	
12	14781ZE1000	ROTATOR, VALVE	1	
13	14791ZE1010	PLATE, PUSH ROD GUIDE	1	
14	90012ZE0010	BOLT, PIVOT	2	
15	90206ZE1000	NUT, PIVOT ADJUSTING	2	



# HONDA GX160K1QMX2HX2 ENGINE — CARBURETOR ASSY.

CARBURETOR ASSY.

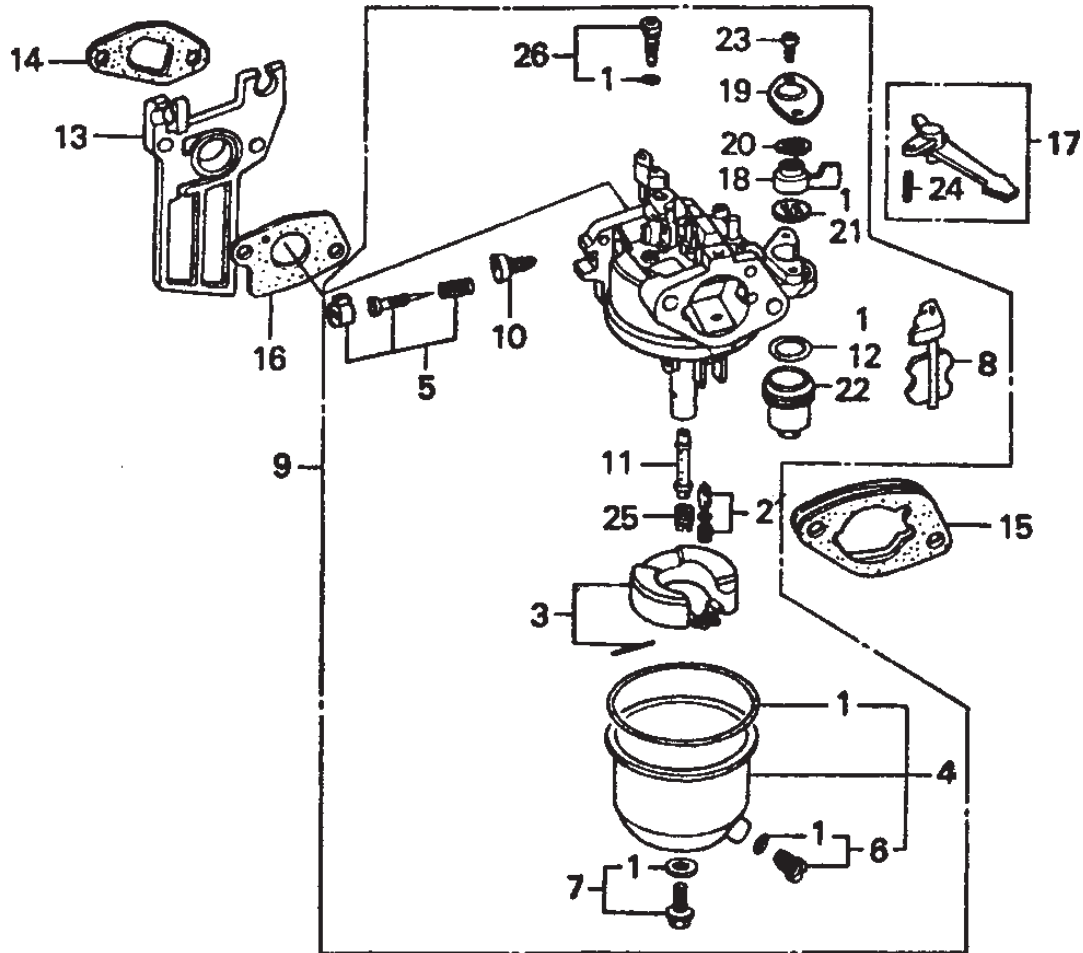

# HONDA GX160K1QMX2HX2 ENGINE — CARBURETOR ASSY.

## CARBURETOR ASSY.

<u>NO</u>	<u>PART NO</u>	<u>PART NAME</u>	<u>QTY.</u>	<u>REMARKS</u>
1*	16010ZE1812	GASKET SET	1	
2*	16011ZE0005	VALVE SET, FLOAT	1	
3*	16013ZE0005	FLOAT SET	1	
4*	16015ZE0831	CHAMBER SET, FLOAT .....	1	INCLUDES ITEMS W/%
5*	16016ZH7W01	SCREW SET	1	
6*%	16024ZE1811	SCREW SET DRAIN	1	
7*	16028ZE0005	SCREW SET B	1	
8*	16044ZE0005	CHOKE SET	1	
9	16100ZH8W51	CARBURETOR ASSY (BE65B) .....	1	INCLUDES ITEMS W/*
10*	16124ZE0005	SCREW, THROTTLE STOP	1	
11*	16166ZH8W50	NOZZLE, MAIN	1	
12*	16955283000	GASKET, FULL STRAINER CUP	1	
13	162111ZE1000	INSULATOR CARBURETOR	1	
14	16212ZH8800	GASKET, INSULATOR	1	
15	16220ZE1020	SPACER COMP. CARBURETOR	1	
16	16221ZH8801	GASKET CARBURETOR	1	
17	16610ZE1000	LEVER COMP., CHOKE (STD) .....	1	INCLUDES ITEMS W/#
18*	16953ZE1406	LEVER VALVE	1	
19*	16954ZE1812	PLATE LEVER SETTING	1	
20*	16956ZE1811	SPRING, PETCOCK LEVER	1	
21*	16957ZE1812	GASKET, PETCOCK	1	
22*	16967ZE0811	CUP, FUEL STRAINER	1	
23*	93500030060H	SCREW, PAN 3X6	2	
24#	9430520122	PIN, SPRING 2X12	1	
25*	99101ZH70650	JET, MAIN #65	1	
	99101ZH70680	JET, MAIN #68	1	
	99101ZH70700	JET, MAIN #70	1	
26*	99204ZE00350	JET SET, PILOT #35	1	

# HONDA GX160K1QMX2HX2 ENGINE — CONTROL ASSY.

CONTROL ASSY.

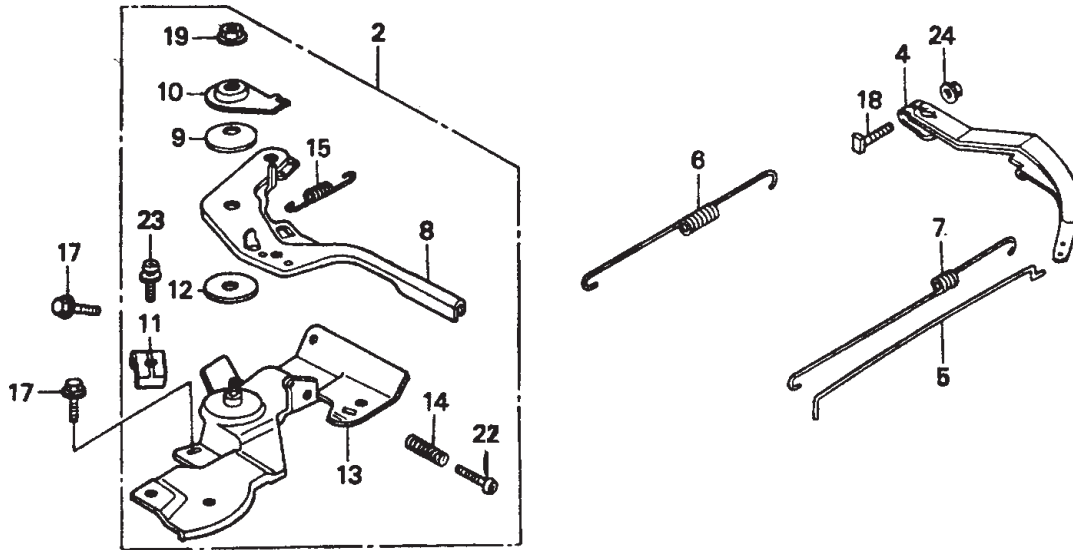

# HONDA GX160K1QMX2HX2 ENGINE — CONTROL ASSY.

## CONTROL ASSY.

<u>NO</u>	<u>PART NO</u>	<u>PART NAME</u>	<u>QTY.</u>	<u>REMARKS</u>
2	16500ZH8821	CONTROL ASSY., REMOTE .....	1	INCLUDES ITEMS W/*
4	16551ZE0010	ARM, GOVERNOR	1	
5	16555ZE1000	ROD, GOVERNOR	1	
6	16561ZE1020	SPRING, GOVERNOR	1	
7	16562ZE1020	SPRING, THROTTLE RETURN	1	
8*	16571ZH8000	LEVER, CONTROL	1	
9*	16574ZE1000	SPRING, LEVER	1	
10*	16575ZH8000	WASHER, CONTROL LEVER	1	
11*	16576891000	HOLDER, CABLE	1	
12*	16578ZE1000	SPACER, CONTROL LEVER	1	
13*	16580ZH8811	BASE COMP., CONTROL	1	
14*	16584883300	SPRING, CONTROL ADJUSTING	1	
15*	16592ZE1810	SPRING, CABLE RETURN	1	
17	90013883000	BOLT, FLANGE (6X12)	2	
18	90015ZE5010	BOLT, GOVERNOR ARM	1	
19*	90114SA0000	NUT, SELF- LOCK (6MM)	1	
22*	93500050250H	SCREW, PAN (5X25)	1	
23*	938930501600	SCREW WASHER (5X16)	1	
24	9405006000	NUT, FLANGE, 6MM	1	

# HONDA GX160K1QMX2HX2 ENGINE — CRANKCASE COVER ASSY.

CRANKCASE COVER ASSY.

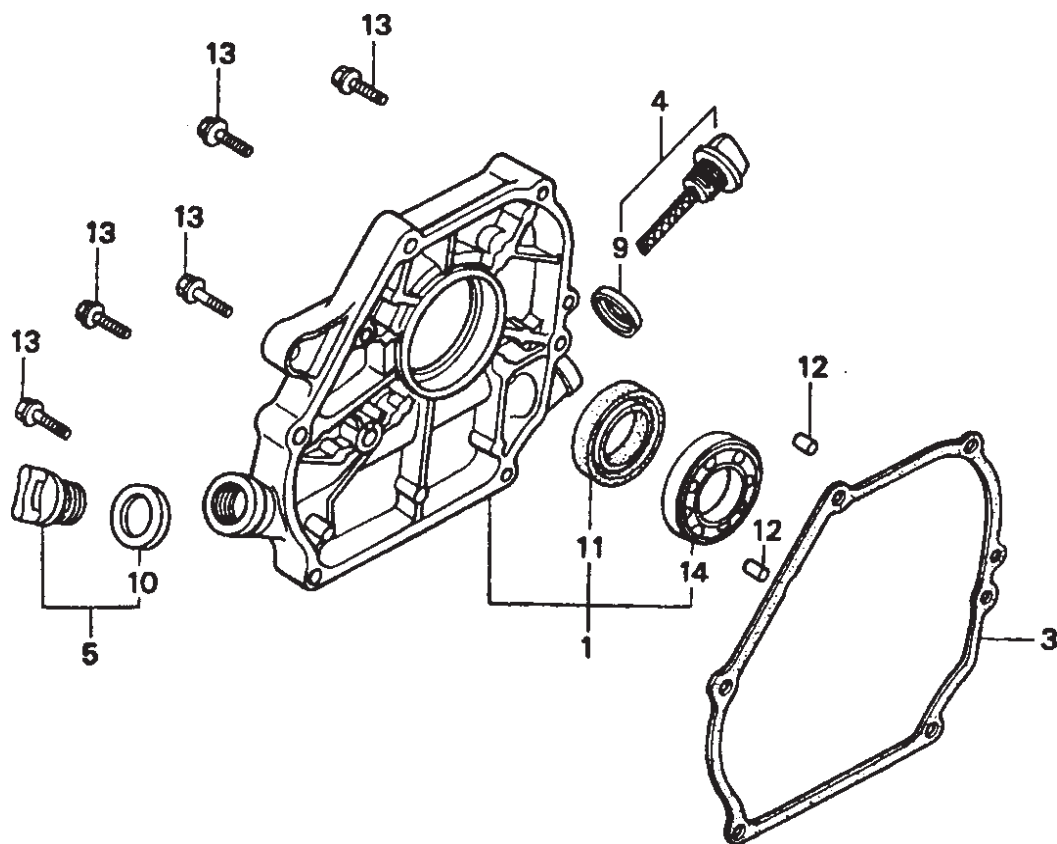

# HONDA GX160K1QMX2HX2 ENGINE — CRANKCASE COVER ASSY.

## CRANKCASE COVER ASSY.

<u>NO</u>	<u>PART NO</u>	<u>PART NAME</u>	<u>QTY.</u>	<u>REMARKS</u>
1	11300ZE1633	COVER ASSY, CRANKCASE (W TYPE) .....	1	INCLUDES ITEMS W/*
3	11381ZH8801	GASKET CASE COVER	1	
4	15600ZE1003	CAP ASSY, OIL FILLER .....	1	INCLUDES ITEMS W/#
5	15600ZG4003	CAP ASSY, OIL FILLER .....	1	INCLUDES ITEMS W/%
9#	15625ZE1003	GASKET, OIL FILLER CAP	1	
10%	15625ZE1003	GASKET, OIL FILLER CAP	1	
11*	91202883005	OIL SEAL, 25X41X6	1	
12	9430108140	PIN A, DOWEL 8X14	2	
13	957010803200	BOLT, FLANGE 8X32	6	
14*	961006205010	BEARING, RADIAL BALL, 6205	1	

# HONDA GX160K1QMX2HX2 ENGINE — CRANKSHAFT ASSY.

CRANKSHAFT ASSY.

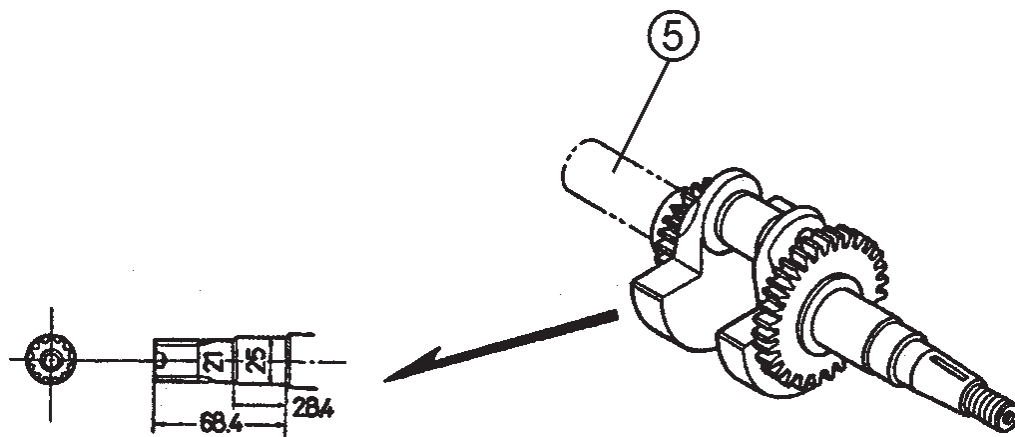

# HONDA GX160K1QMX2HX2 ENGINE — CRANKSHAFT ASSY.

CRANKSHAFT ASSY.

<u>NO.</u>	<u>PART NO.</u>	<u>PART NAME</u>	<u>QTY.</u>	<u>REMARKS</u>
5	13310ZE1621	CRANKSHAFT (H-TYPE)	1	



# HONDA GX160K1QMX2HX2 ENGINE — CYLINDER BARREL ASSY.

CYLINDER BARREL ASSY.

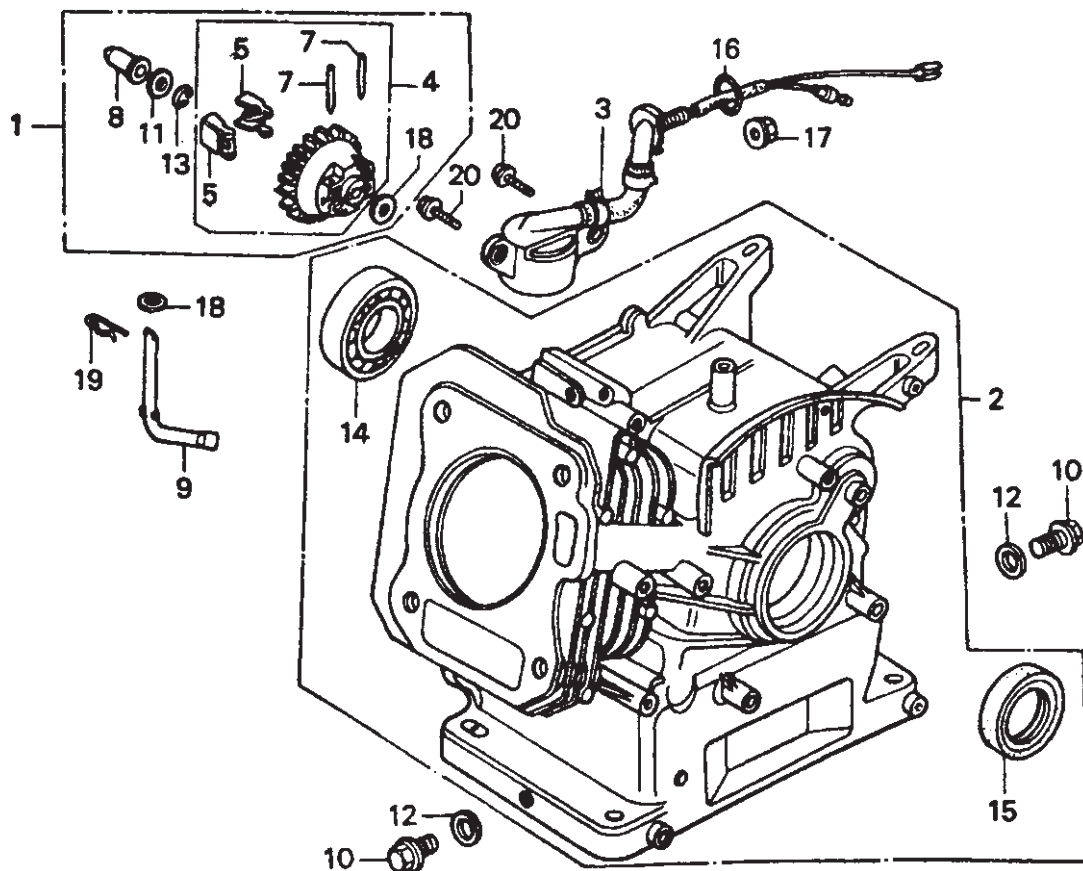

# HONDA GX160K1QMX2HX2 ENGINE — CYLINDER BARREL ASSY.

## CYLINDER BARREL ASSY.

<u>NO</u>	<u>PART NO</u>	<u>PART NAME</u>	<u>QTY.</u>	<u>REMARKS</u>
1	06165ZE1000	GOVERNOR KIT .....	1 .....	INCLUDES ITEMS W/*
2	12000ZH8811	CYLINDER ASSY. BARREL OIL ALERT .....	1 .....	INCLUDES ITEMS W%
3	15510ZE1023	SWITCH ASSY. OIL LEVEL	1	
4*	16510ZE1000	GOVERNOR ASSY. ....	1 .....	INCLUDES ITEMS/W#
5*#	16511ZE1000	WEIGHT, GOVERNOR	2	
7*#	16513ZE1000	PIN, GOVERNOR WEIGHT	2	
8*	16531ZE1000	SLIDER, GOVERNOR	1	
9	16541ZE1000	SHAFT, GOVERNOR ARM	1	
10	90131ZE1000	BOLT, DRAIN PLUG	2	
11*	90451ZE1000	WASHER, THRUST 6MM	1	
12	90601ZE1000	WASHER, DRAIN PLUG 10.2MM	2	
13*	90602ZE1000	CLIP, GOVERNOR HOLDER	1	
14%	91001ZF1003	BEARING, RADIAL BALL(6205)	1	
15%	91202883005	OIL SEAL 25x41x6	1	
16	91353671003	O-RING 14MM ARAI	1	
17	9405010000	NUT, FLANGE 10MM	1	
18*	9410106800	WASHER, PLAIN, 6MM	2	
19	9425108000	PIN, LOCK, 8MM	1	
20	957010601200	BOLT, FLANGE 6 x 12	2	

# HONDA GX160K1QMX2HX2 ENGINE — CYLINDER HEAD ASSY.

CYLINDER HEAD ASSY.

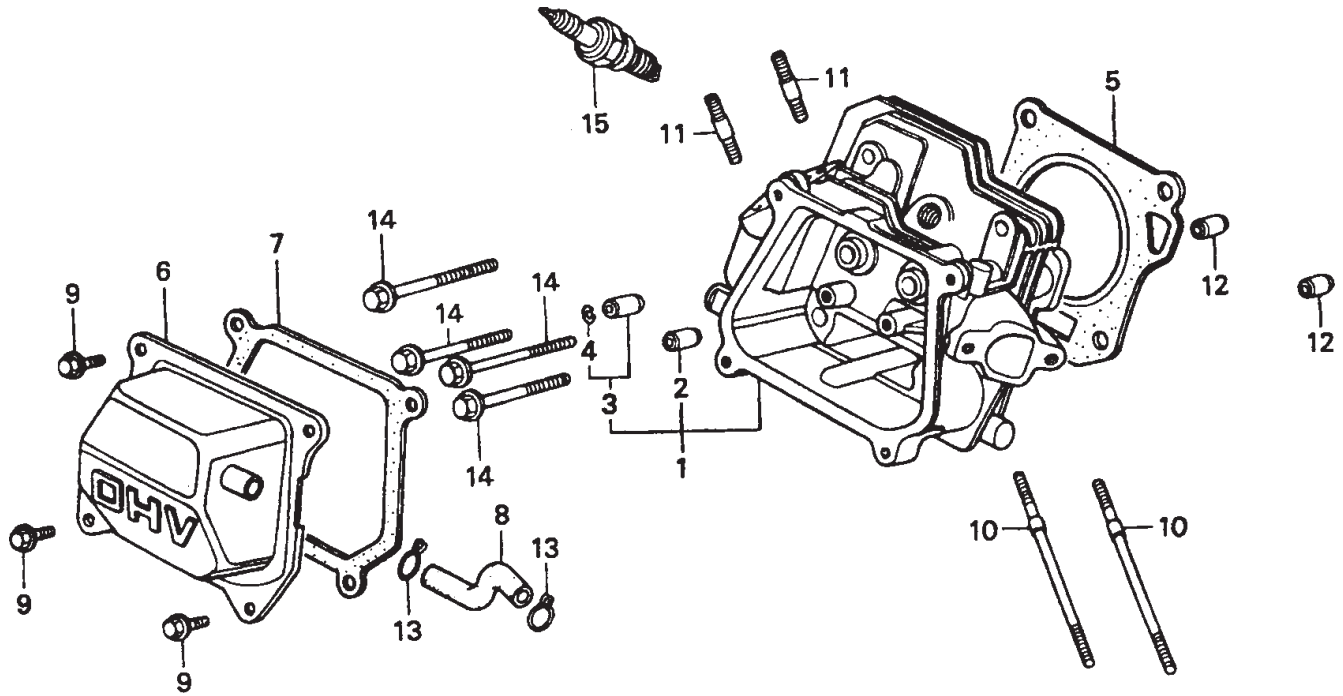

# HONDA GX160K1QMX2HX2 ENGINE — CYLINDER HEAD ASSY.

## CYLINDER HEAD ASSY.

<u>NO</u>	<u>PART NO</u>	<u>PART NAME</u>	<u>QTY.</u>	<u>REMARKS</u>
1	12210ZH8000	CYLINDER HEAD, COMP .....	1 .....	INCLUDES ITEMS W/*
2*	12204ZE1306	GUIDE, IN. VALVE (OVER SIZE)	1	
3*	12205ZE1315	GUIDE, EX. VALVE (OS)	1	
4	12216ZE5300	CLIP, VALVE GUIDE	1	
5	12251ZF1800	GASKET, CYLINDER HEAD	1	
6	12310ZE1010	COVER COMP, HEAD	1	
7	12391ZE1000	GASKET, CYLINDER HEAD COVER	1	
8	15721ZH8000	TUBE, BREATHER	1	
9	90016ZE1000	BOLT, FLANGE 6X13	4	
10	90043ZE1020	BOLT, STUD 6X109	2	
11	90047ZE1000	BOLT, STUD 8X32	2	
12	9430110160	PIN A, DOWEL 10X16	2	
14	957230806000	BOLT, FLANGE 8X60	4	
15	9807956846	PLUG, SPARK (BPR6ES NGK)	1	
	9807956855	PLUG, SPARK (W20EPR-U ND)	1	

# HONDA GX160K1QMX2HX2 ENGINE — FAN COVER ASSY.

FAN COVER ASSY.

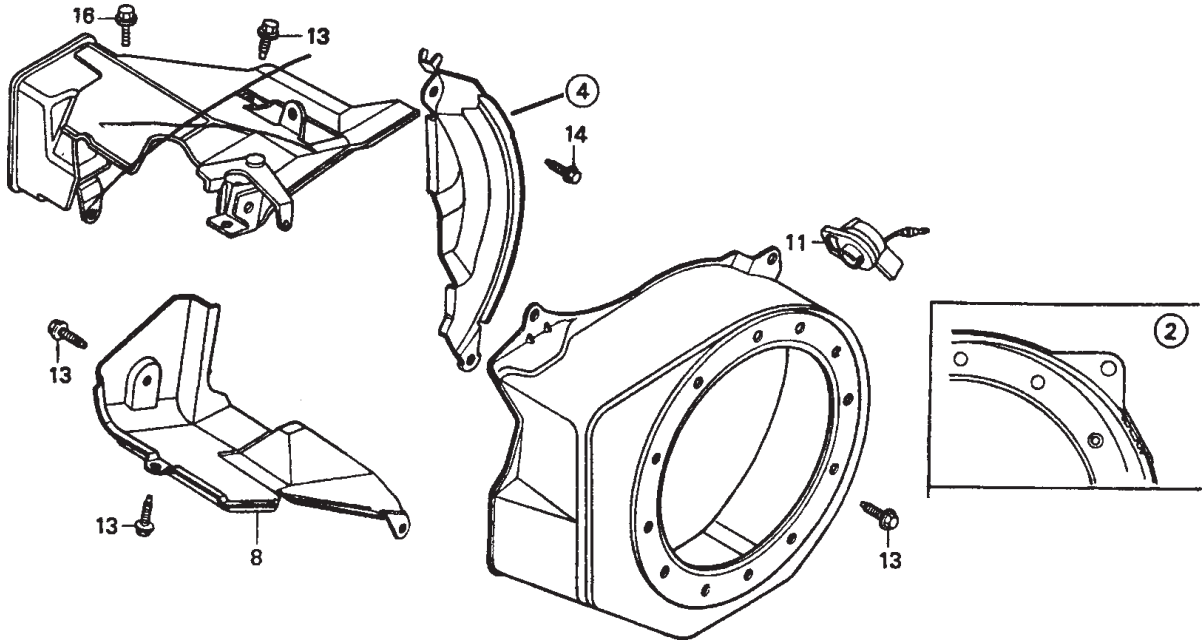

# HONDA GX160K1QMX2HX2 ENGINE — FAN COVER ASSY.

## FAN COVER ASSY.

<u>NO</u>	<u>PART NO</u>	<u>PART NAME</u>	<u>QTY.</u>	<u>REMARKS</u>
2	19610ZE1000ZC	COVER COMP., FAN NH1(BLACK)	1	
4	19612ZH8810	PLATE, SIDE (STD)	1	
7	90601ZH7013	CLIP, HARNESS	1	
8	19630ZH8000	SHROUD COMP.	1	
10	32197ZH8003	SUB-HARNESS	1	
11	36100ZE1015	SWITCH ASSY., ENGINE	1	
14	90022888010	BOLT, FLANGE 6X20	1	

# HONDA GX160K1QMX2HX2 ENGINE — FLYWHEEL ASSY.

FLYWHEEL ASSY.

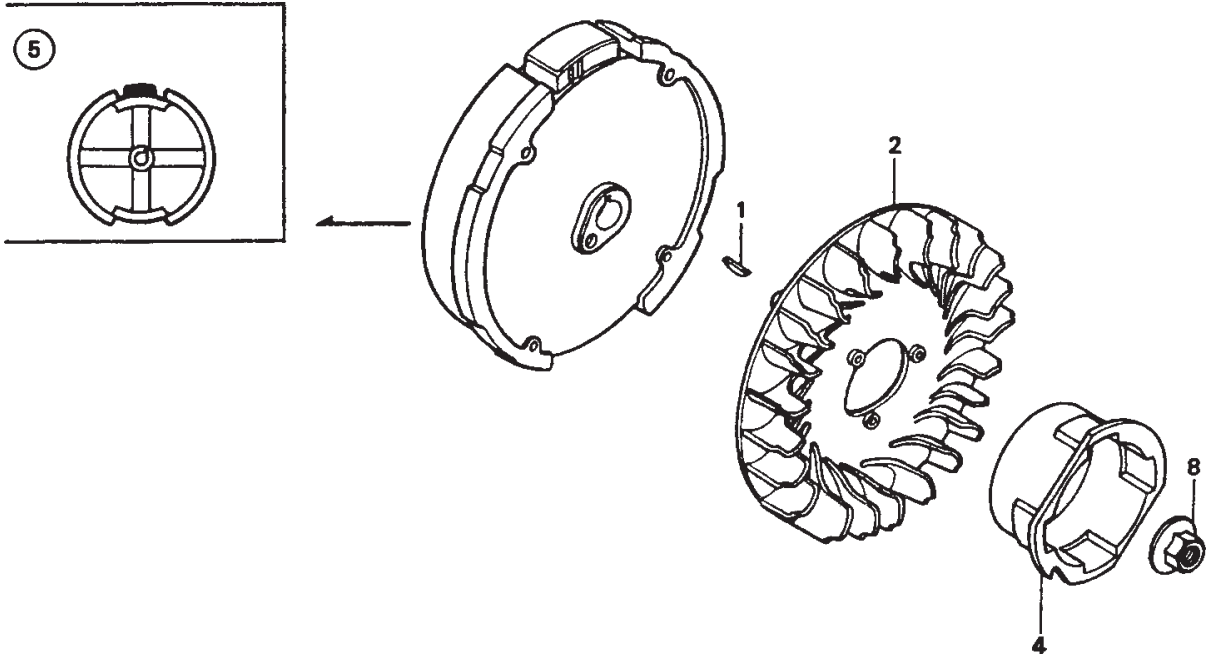

# HONDA GX160K1QMX2HX2 ENGINE — FLYWHEEL ASSY.

## FLYWHEEL ASSY.

<u>NO</u>	<u>PART NO</u>	<u>PART NAME</u>	<u>QTY.</u>	<u>REMARKS</u>
1	13331357000	KEY, SPECIAL WOOD RUFF, 25X18	1	
2	19511ZE1000	FAN, COOLING	1	
4	28451ZH8003	PULLEY STARTER	1	
5	31100ZE1000	FLYWHEEL COMP.	1	
8	90201878003	NUT, SPECIAL, 14MM	1	



# HONDA GX160K1QMX2HX2 ENGINE — MUFFLER ASSY.

MUFFLER ASSY.

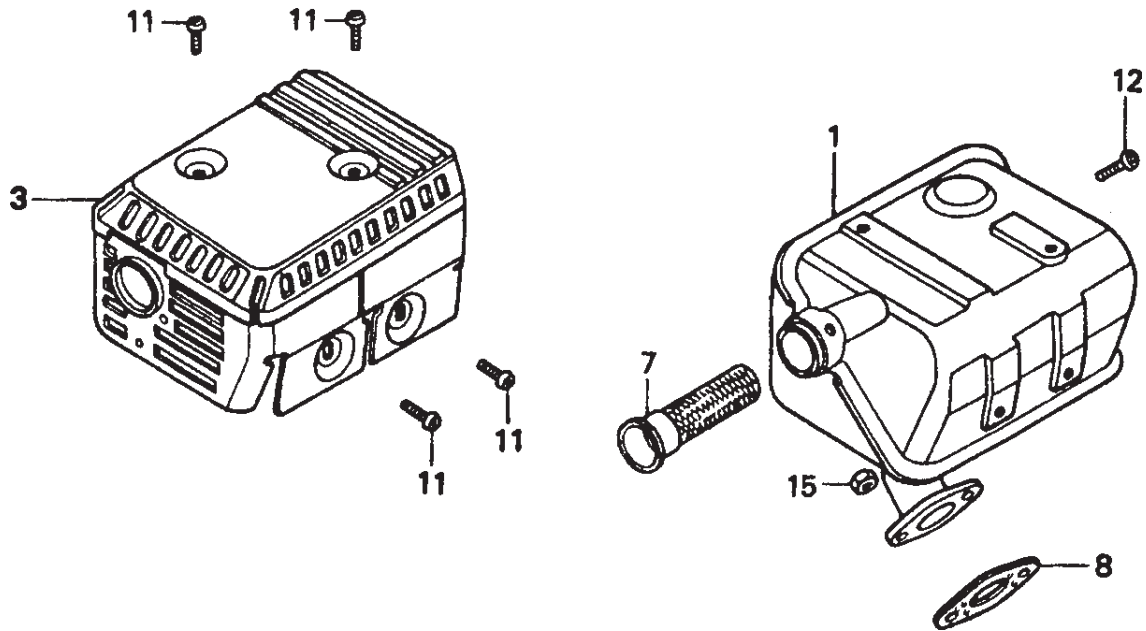

# HONDA GX160K1QMX2HX2 ENGINE — MUFFLER ASSY.

## MUFFLER ASSY.

<u>NO</u>	<u>PART NO</u>	<u>PART NAME</u>	<u>QTY.</u>	<u>REMARKS</u>
1	18310ZH8810	MUFFLER COMP.	1	
3	18320ZF1H01	PROTECTOR, MUFFLER	1	
7	18355ZE1000	ARRESTER, SPARK	1	
8	18381ZH8800	GASKET, MUFFLER	1	
11	90050ZE1000	SCREW, TAPPING 5X8	4	
12	90055ZE1000	SCREW, TAPPING 4X6	1	
15	94001080000S	NUT, HEX (8MM)	2	

# HONDA GX160K1QMX2HX2 ENGINE — FUEL TANK ASSY.

FUEL TANK ASSY.

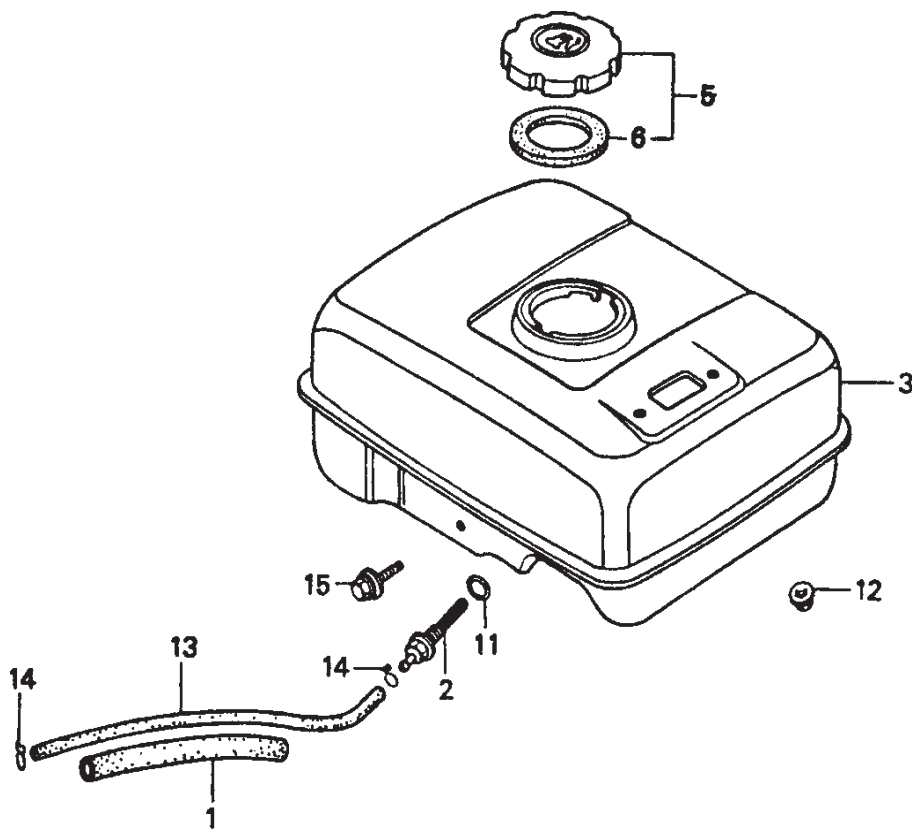

# HONDA GX160K1QMX2HX2 ENGINE — FUEL TANK ASSY.

## FUEL TANK ASSY.

<u>NO</u>	<u>PART NO</u>	<u>PART NAME</u>	<u>QTY.</u>	<u>REMARKS</u>
1	16854ZH8000	RUBBER, SUPPORTER	1	
2	16955ZE1000	JOINT, FUEL TANK	1	
3	17510ZE1020ZF	TANK COMP., FUEL NH1 (BLACK)	1	
5	17620ZH7013	CAP COMP., FUEL FILLER .....	1	INCLUDES ITEMS W/#
6#	17631ZH7003	GASKET, FUEL FILLER CAP	1	
11	91353671003	O-RING (14MM) ARAI	1	
12	9405006000	NUT, FLANGE (6MM)	2	
13	950014500840M	BULK HOSE, FUEL (4.5X8000) (4.5X140)	1	
14	9500202080	CLIP, TUBE (B8)	2	
15	957010602500	BOLT, FLANGE (6X25)	1	

# HONDA GX160K1QMX2HX2 ENGINE — IGNITION COIL ASSY.

IGNITION COIL ASSY.

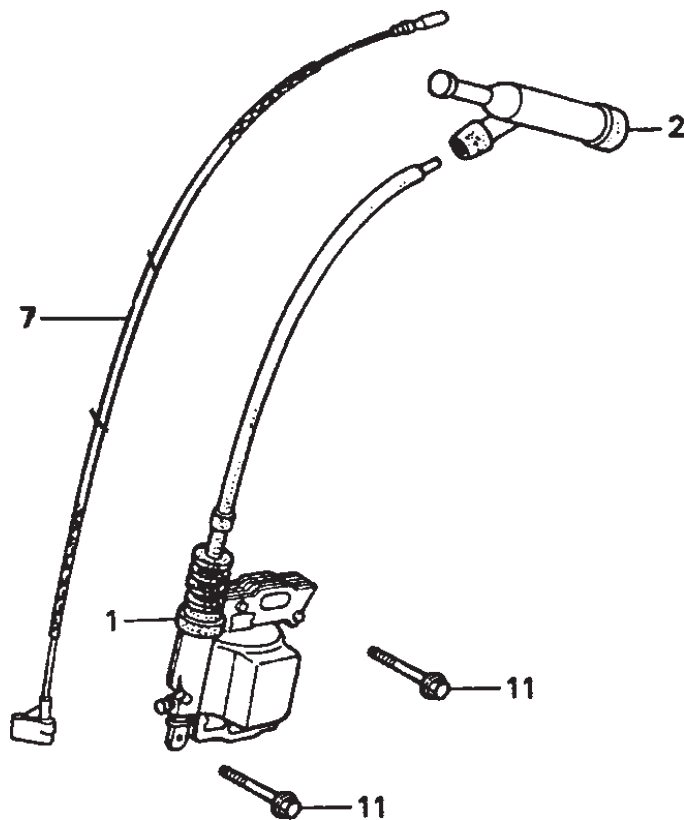

## HONDA GX160K1QMX2HX2 ENGINE — IGNITION COIL ASSY.

### IGNITION COIL ASSY.

<u>NO</u>	<u>PART NO</u>	<u>PART NAME</u>	<u>QTY.</u>	<u>REMARKS</u>
1	30500ZE1033	COIL ASSY., IGNITION	1	
2	30700ZE1013	CAP ASSY., NOISE SUPPRESSOR	1	
7	36101ZE1010	WIRE, STOP SWITCH (370MM)	1	
11	90121952000	BOLT, FLANGE, 6X25	2	

# HONDA GX160K1QMX2HX2 ENGINE — PISTON ASSY.

PISTON ASSY.

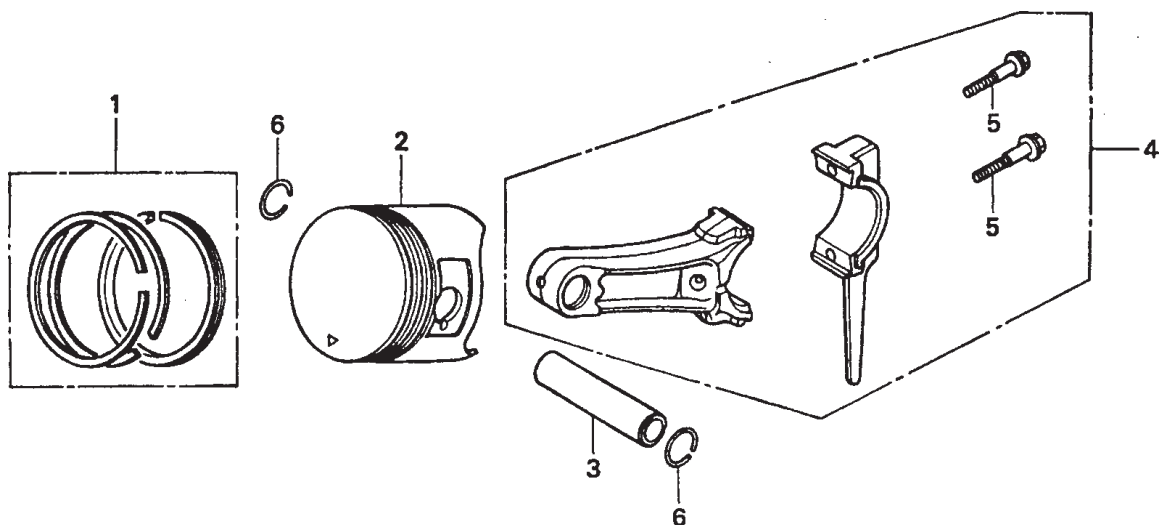

# HONDA GX160K1QMX2HX2 ENGINE — PISTON ASSY.

## PISTON ASSY.

<u>NO</u>	<u>PART NO</u>	<u>PART NAME</u>	<u>QTY.</u>	<u>REMARKS</u>
1	13010ZF1023	RING SET, PISTON (STD)	1	
	13011ZF1023	RING SET, PISTON (0.25)	1	
	13012ZF1023	RING SET, PISTON (0.50)	1	
	13013ZF1023	RING SET, PISTON (0.75)	1	
2	13101ZH8000	PISTON (STD)	1	
	13102ZH8000	PISTON (0.25)	1	
	13103ZH8000	PISTON (0.50)	1	
	13104ZH8000	PISTON (0.75)	1	
3	13111ZE1000	PIN, PISTON	1	
4	132A0ZE1000	ROD ASSY, CONNECTING .....	1	INCLUDES ITEMS W/*
5*	90001ZE1000	BOLT, CONNECTING ROD	2	
6	90551ZE1000	CLIP, PISTON PIN, 18MM	2	



# HONDA GX160K1QMX2HX2 ENGINE — RECOIL STARTER ASSY.

RECOIL STARTER ASSY.

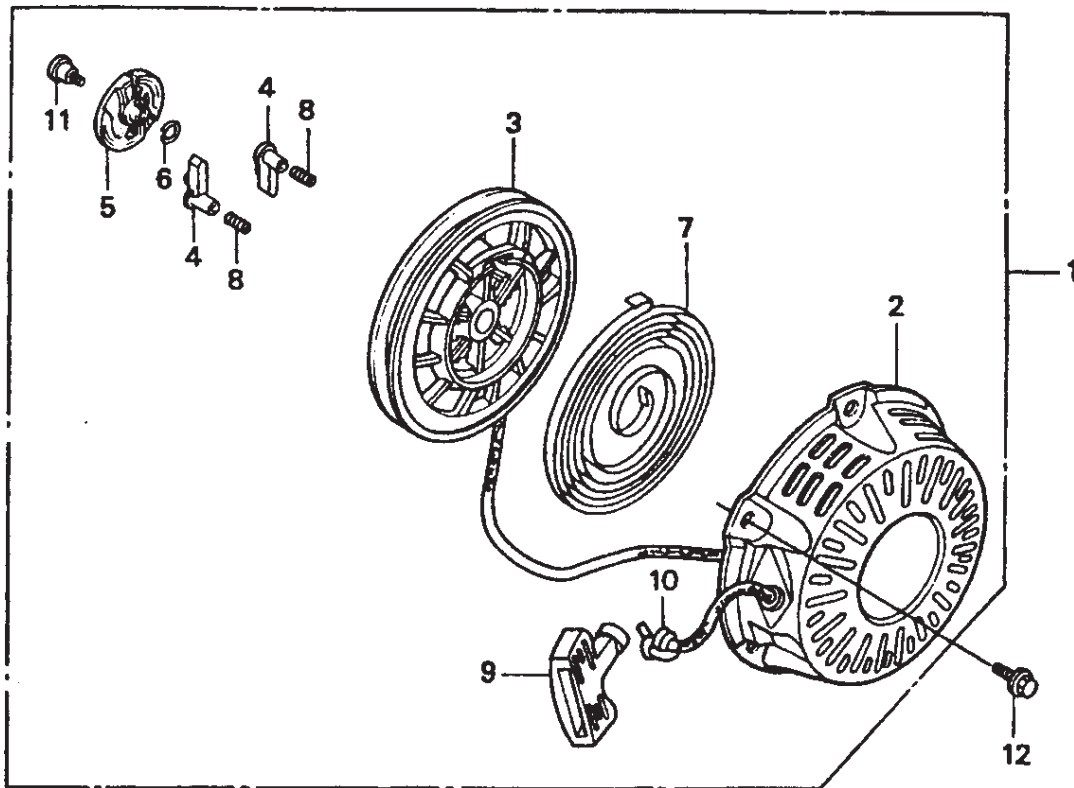

# HONDA GX160K1QMX2HX2 ENGINE — RECOIL STARTER ASSY.

## RECOIL STARTER ASSY.

<u>NO</u>	<u>PART NO</u>	<u>PART NAME</u>	<u>QTY.</u>	<u>REMARKS</u>
1	28400ZH8013ZB	STARTER ASSY, RECOIL NH1(BLACK)	1	INCLUDES ITEMS W/*
2*	28410ZH8003ZB	CASE COMP, RECOIL STARTER	1	
3*	28420ZH8013	REEL, RECOIL STARTER	1	
4*	28422ZH8013	RATCHET, STARTER	2	
5*	28433ZH8003	GUIDE, RATCHET	1	
6*	28441ZH8003	SPRING, FRICTION	1	
7*	28442ZH8003	SPRING, RECOIL STARTER	1	
8*	28443ZH8003	SPRING, RETURN	2	
9*	28461ZH8003	KNOB, RECOIL STARTER	1	
10*	28462ZH8003	ROPE, RECOIL STARTER	1	
11*	90003ZH8003	SCREW, SETTING	1	
12	957010600800	BOLT, FLANGE 6X8	3	

# HONDA GX160K1QMX2HX2 ENGINE — GEAR REDUCTION ASSY.

GEAR REDUCTION ASSY.

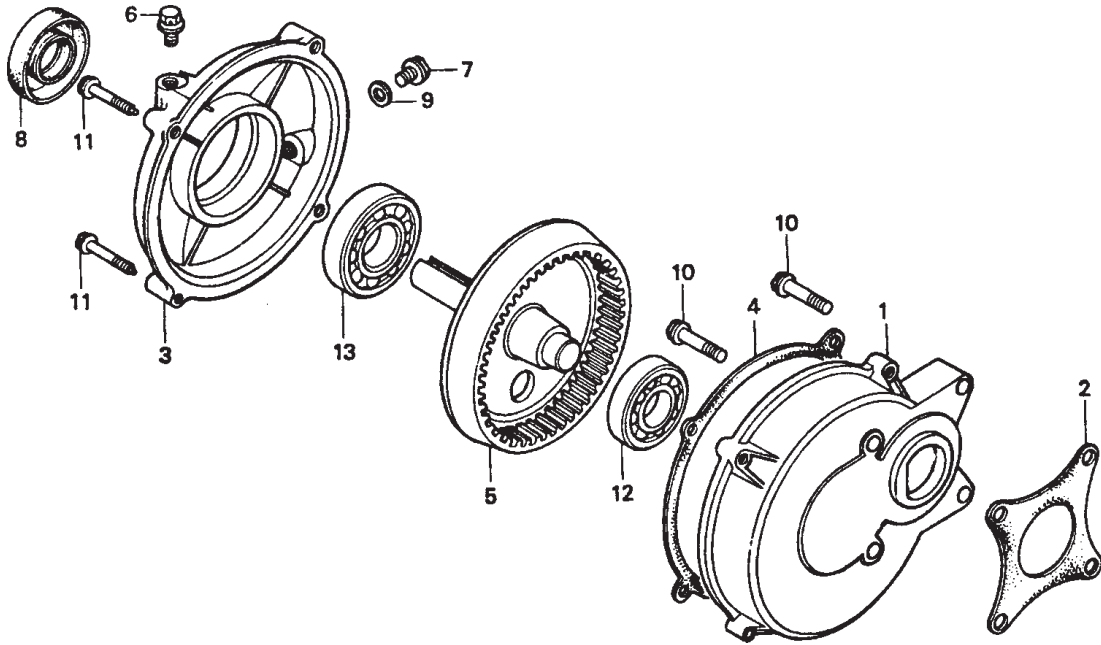

# HONDA GX160K1QMX2HX2 ENGINE — GEAR REDUCTION ASSY.

## GEAR REDUCTION ASSY.

<u>NO.</u>	<u>PART NO.</u>	<u>PART NAME</u>	<u>QTY.</u>	<u>REMARKS</u>
1	21521883741	CASE, REDUCTION	1	
2	21591ZH8740	GASKET, REDUCTION CASE	1	
3	21621883741	COVER, REDUCTION	1	
4	21692ZH8800	GASKET, REDUCTION COVER	1	
5	23710883740	SHAFT, P.T.O.	1	
6	90002883740	BOLT, BREATHING	1	
7	90131883000	BOLT, DRAIN PLUG	1	
8	91202883005	OIL SEAL, 25 x 41 x 6	1	
9	9410912000	WASHER, DRAIN PLUG	1	
10	957010803208	BOLT, FLANGE 8 x 32	1	
11	957010803500	BOLT, FLANGE 8 x 35	1	
12	961006204000	BEARING, RADIAL BALL 6204	1	
13	961006305000	BEARING, RADIAL BALL 6305	1	

# HONDA GX160K1QMX2HX2 ENGINE — LABEL ASSY.

LABEL ASSY.

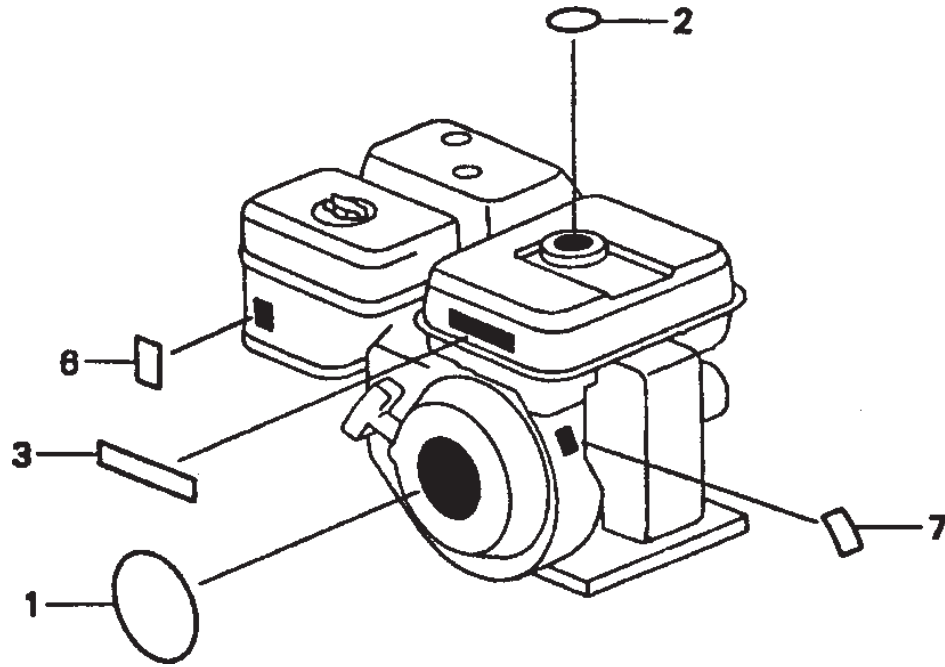

# HONDA GX160K1QMX2HX2 ENGINE — LABEL ASSY.

## LABEL ASSY.

<u>NO</u>	<u>PART NO</u>	<u>PART NAME</u>	<u>QTY.</u>	<u>REMARKS</u>
1	87521ZH8010	EMBLEM, INTERNAL	1	
2	87522ZE1810	MARK, CAUTION EXTERNAL	1	
3	87522ZH9000	LABEL, CAUTION	1	
6	87258ZE1810	MARK, CHOKE	1	
7	87530ZH8810	LABEL, SPECIFICATION EXTERNAL	1	
8	87532ZB4G60	MARK, OIL ALERT G	1	
	87532ZB4H50	MARK, OIL ALERT F	1	
	87532ZH8810	MARK, OIL ALERT E	1	

# HONDA GX240K1HA2 ENGINE — AIR CLEANER ASSY.

AIR CLEANER ASSY.

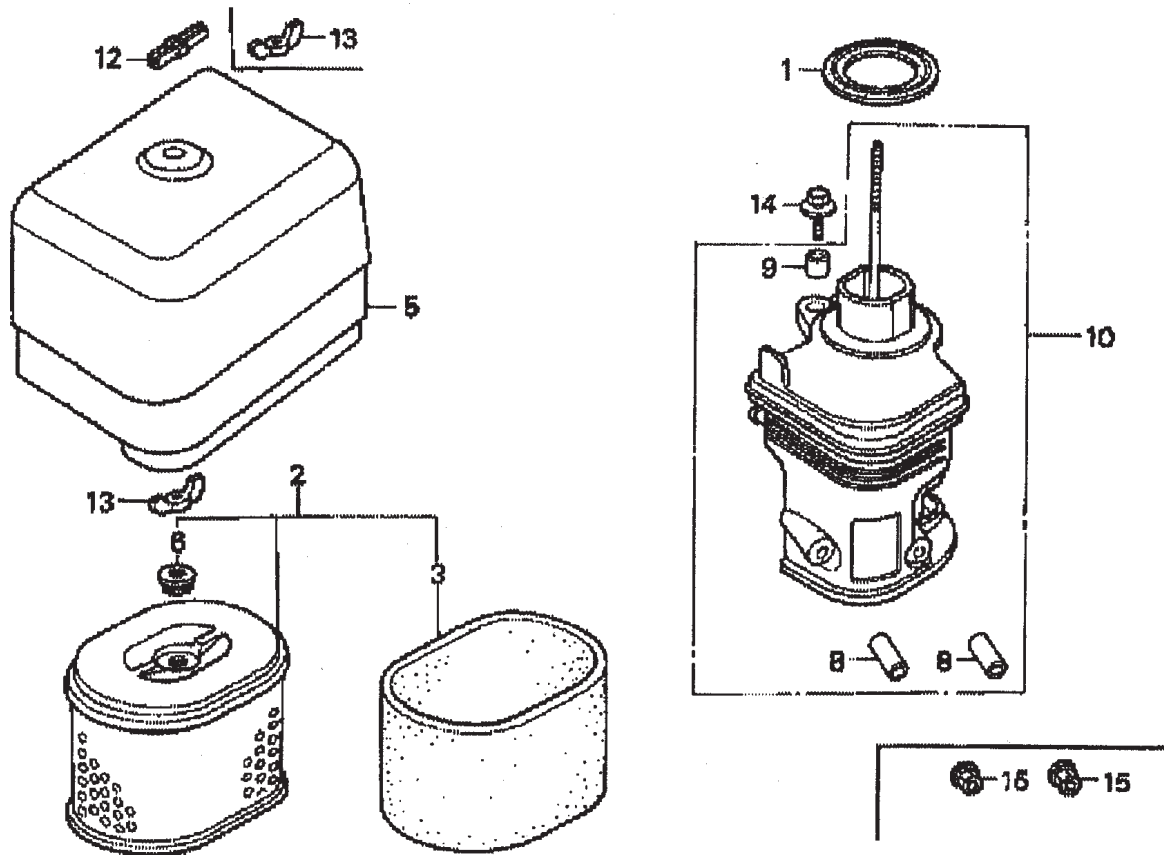

# HONDA GX240K1HA2 ENGINE — AIR CLEANER ASSY.

## AIR CLEANER ASSY.

<u>NO.</u>	<u>PART NO.</u>	<u>PART NAME</u>	<u>QTY.</u>	<u>REMARKS</u>
1	16271ZE2000	GASKET, ELBOW .....	1 .....	INCLUDES ITEM W/*
2	17210ZE2515	ELEMENT, AIR CLEANER, DUAL	1	
3 *	17218ZE2505	FILTER, OUTER	1	
5	17231ZH9820	COVER, AIR CLEANER	1	
6	17232891000	GROMMET, AIR CLEANER	1	
8 #	17238ZE2310	COLLAR, AIR CLEANER	2	
9 #	17239ZE1000	COLLAR B, AIR CLEANER	1	
10	17410ZE2020	ELBOW COMP., AIR CLEANER .....	1 .....	INCLUDES ITEM W/#
12	0037806000	WINGNUT 6MM	1	
13	90325044000	WINGNUT, TOOL BOX SETTING	2	
14	90009ZE2003	BOLT- WASHER 6 X 22	1	
15	9405006000	NUT, FLANGE 6MM	2	



# HONDA GX240K1HA2 ENGINE — CAMSHAFT ASSY.

CAMSHAFT ASSY.

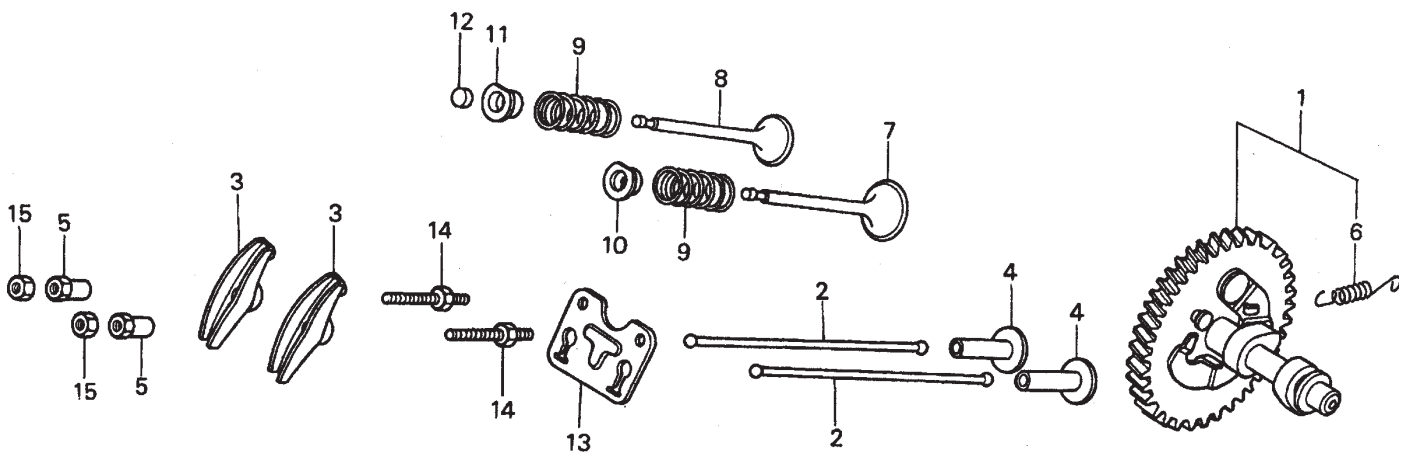

# HONDA GX240K1HA2 ENGINE — CAMSHAFT ASSY.

## CAMSHAFT ASSY.

<u>NO.</u>	<u>PART NO.</u>	<u>PART NAME</u>	<u>QTY.</u>	<u>REMARKS</u>
1	14100ZE2W01	CAMSHAFT ASSY. ....	1	INCLUDES ITEM W/*
1	14100ZE2306	CAMSHAFT	1	
2	14410ZE2013	ROD PUSH	2	
3	14431ZE2010	ARM VALVE ROCKER	2	
4	14441ZE2000	LIFTER VALVE	2	
5	14451ZE1013	PIVOT ROCKER ARM	2	
6*	14568ZE1000	SPRING, WEIGHT RETURN	1	
7	14711ZE2000	VALVE, IN.	1	
8	14721ZE2000	VALVE, EX.	1	
9	14751ZE2003	SPRING, VALVE	2	
10	14771ZE2000	RETAINER, IN. VALVE SPRING	1	
11	14773ZE2000	RETAINER, EX. VALVE SPRING	1	
12	14781ZE2000	ROTATOR, VALVE	1	
13	14791ZE2010	PLATE, PUSH ROD GUIDE	1	
14	90012ZE0010	BOLT, PIVOT 8MM	2	
15	90206ZE1000	NUT, PIVOT ADJ.	2	

# HONDA GX240K1HA2 ENGINE — CARBURETOR ASSY.

CARBURETOR ASSY.

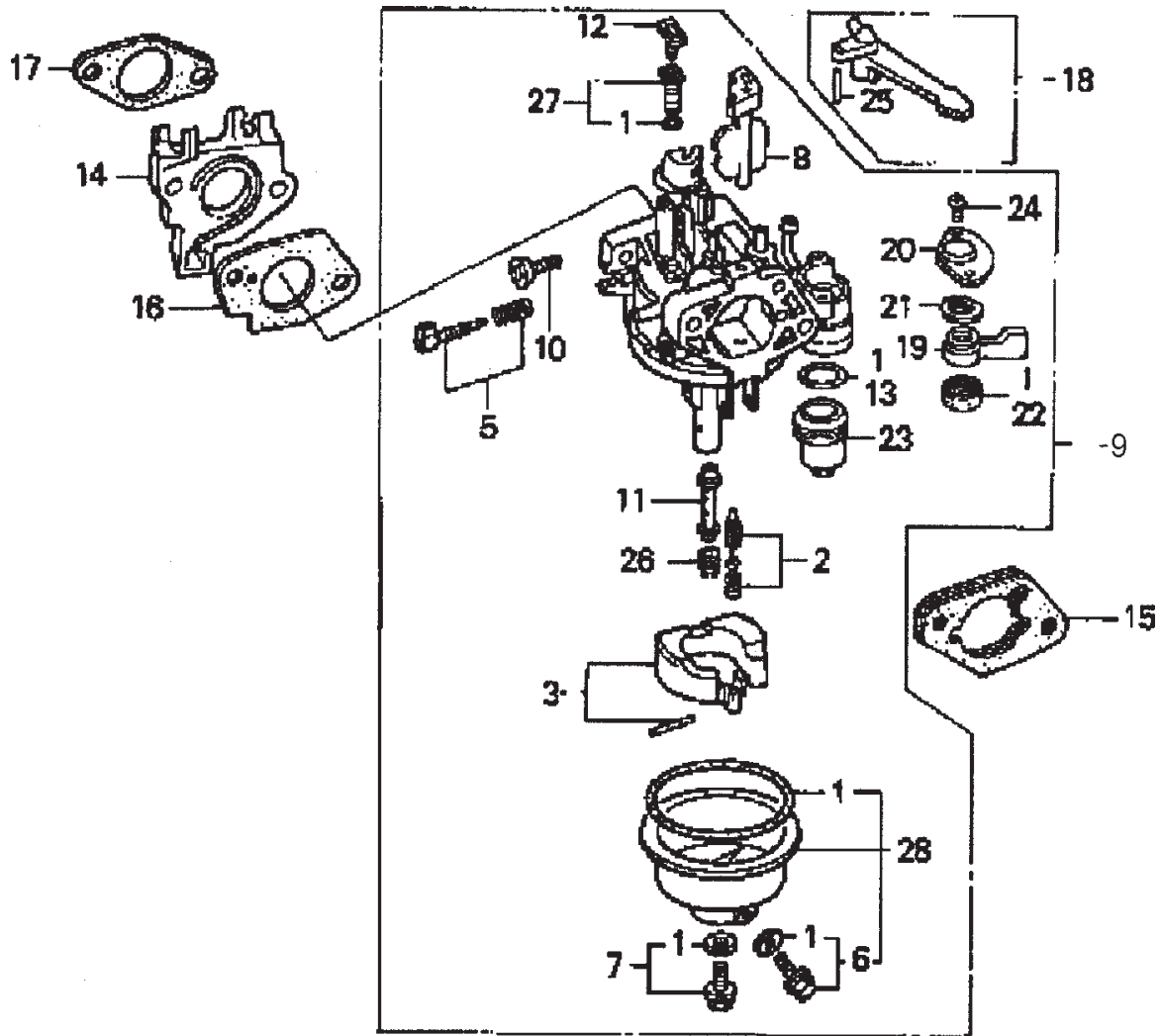

# HONDA GX240K1HA2 ENGINE — CARBURETOR ASSY.

## CARBURETOR ASSY.

<u>NO.</u>	<u>PART NO.</u>	<u>PART NAME</u>	<u>QTY.</u>	<u>REMARKS</u>
1*+	16010ZE2812	GASKET SET	1	
2*	16011ZA0931	VALVE SET, FLOAT	1	
3*	16013ZA0931	FLOAT SET	1	
5*	16016ZHW01	SCREW SET	1	
6*+	16024ZE1811	SCREW SET, DRAIN	1	
7*+	16028ZE0005	SCREW SET B	1	
8*	16028ZE2005	CHOKE SET	1	
9*	16100ZE2W71	CARBURETOR ASSY.....	1	INCLUDES ITEMS W/*
10*	16124ZE0005	SCREW, THROTTLE STOP	1	
11*	16166ZE2W70	NOZZLE, MAIN	1	
12*	16075GHBB00	COLLAR, SET	1	
13*	16075GHBB00	O-RING	1	
14	16211ZE2000	INSULATOR, CARB.	1	
15	16220ZA0702	SPACER COMP., CARB.	1	
16	16221ZA0800	GASKET, CARBURETOR	1	
17	16223ZA0800	GASKET, INSULATOR	1	
18	16610ZE1000	LEVER COMP., CHOKE, STD.	1	
19*	16953ZE1812	LEVER, VALVE	1	
20*	16954ZE1811	PLATE, LEVER SETTING	1	
21*	16956ZE1811	SPRING, VALVE LEVER	1	
22*	16957ZE1812	GASKET, VALVE	1	
23*	16967ZE0811	CUP, FUEL STRAINER	1	
24*	93500030060H	SCREW, PAN 3 X 6	2	
25	9430520122	PIN, SPRING 2 X 12	1	
26*	99101ZH70820	JET, MAIN #82, OPTIONAL	1	
26*	99101ZH70850	JET, MAIN #85, OPTIONAL	1	
26*	99101ZH80880	JET, MAIN #88	1	
27*	99204ZE20400	JET SET, PILOT #40	1	
28*	16015ZE8005	CHAMBER SET, FLOAT .....	1	INCLUDES ITEMS W/+

# HONDA GX240K1HA2 ENGINE — CONTROL ASSY.

CONTROL ASSY.

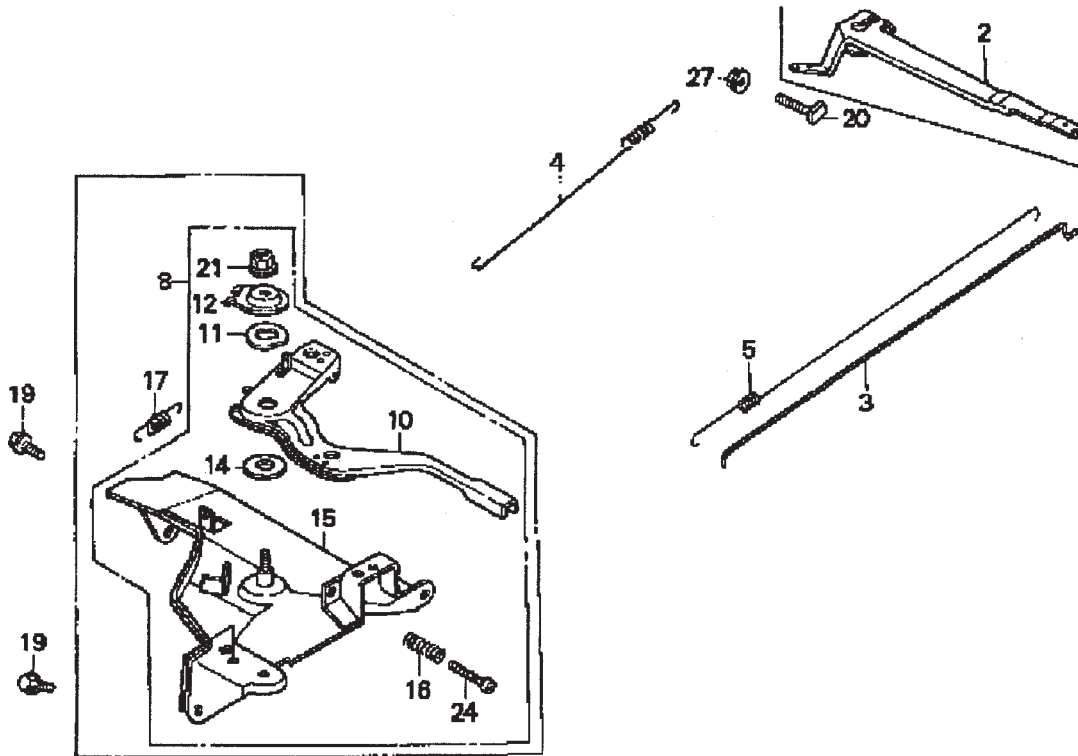

# HONDA GX240K1HA2 ENGINE — CONTROL ASSY.

CONTROL ASSY.

<u>NO.</u>	<u>PART NO.</u>	<u>PART NAME</u>	<u>QTY.</u>	<u>REMARKS</u>
2	16551ZE2000	ARM, GOVERNOR	1	
3	16555ZE2000	ROD, GOVERNOR	1	
4	16561ZE2000	SPRING, GOVERNOR	1	
5	16571ZE2000	SPRING, THROTTLE RETURN	1	
8	16570ZE2W00	CONTROL ASSEMBLY .....	1	INCLUDES ITEMS W/*
10*	16571ZE2W00	LEVER, CONTROL	1	
11*	16574ZE1000	SPRING, LEVER	1	
12*	16575ZE2W00	WASHER, CONTROL LEVER	1	
14*	16578ZE1000	SPACER, CONTROL LEVER	1	
15*	16581ZE2W00	BASE, CONTROL	1	
16*	16584883300	SPRING, CONTROL ADJUSTING	1	
19	90013883000	BOLT, FLANGE (6 X 12) (CT200)	2	
20	90015ZE5010	BOLT, GOVERNOR ARM	1	
21*	90114SA0000	NUT, SELF- LOCK (6MM)	1	
24*	93500050280A	SCREW, PAN (5 X 28)	1	
27	9405006000	NUT, FLANGE	1	

# HONDA GX240K1HA2 ENGINE — CRANKCASE COVER ASSY.

CRANKCASE COVER ASSY.

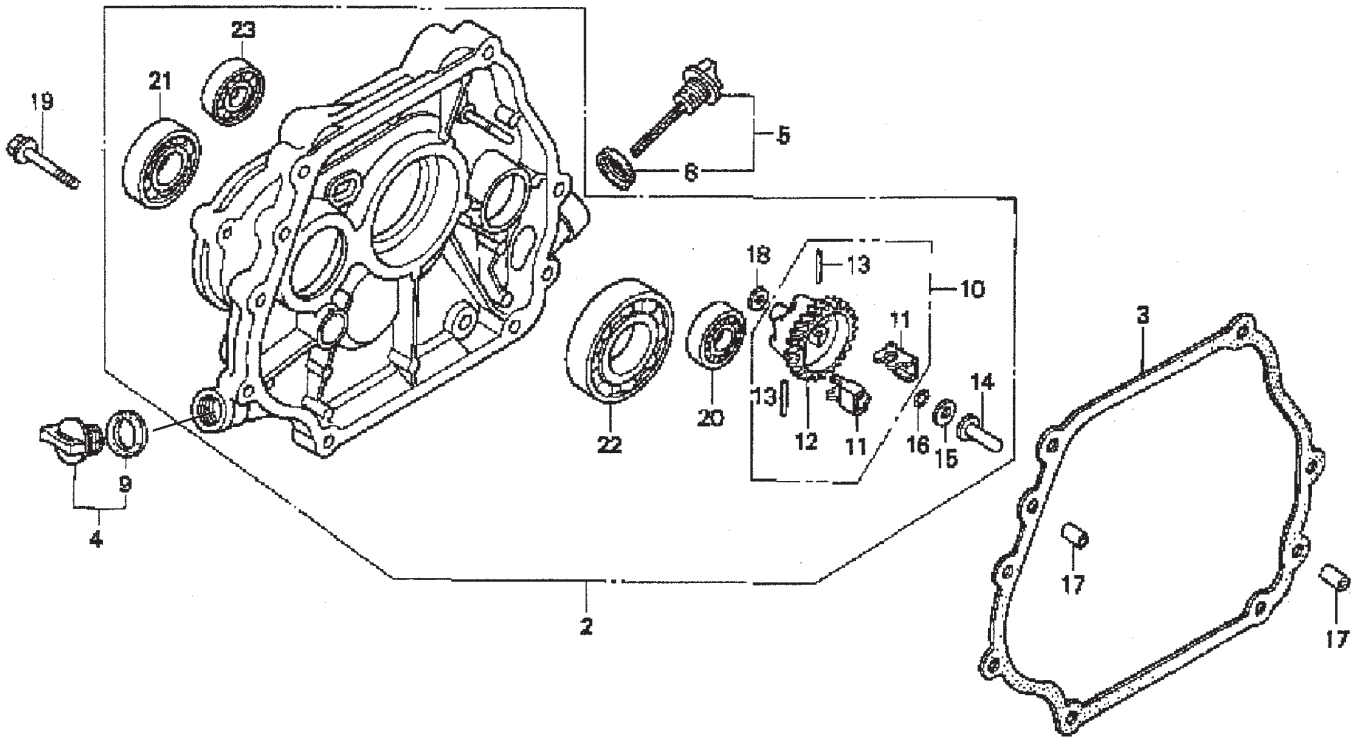

# HONDA GX240K1HA2 ENGINE — CRANKCASE COVER ASSY.

## CRANKCASE COVER ASSY.

<u>NO.</u>	<u>PART NO.</u>	<u>PART NAME</u>	<u>QTY.</u>	<u>REMARKS</u>
2	11400ZE2621	COVER ASSY., CRANKCASE ..... (H-TYPE) (BALANCER)	1 .....	INCLUDES ITEMS W/*
3	11381ZE2801	GASKET, CASE COVER	1	
4	15600ZG4003	CAP ASSY., OIL FILLER .....	1 .....	INCLUDES ITEMS W/#
5	15600735003	CAP ASSY., OIL FILLER .....	1 .....	INCLUDES ITEMS W/%
8%	15625ZE1003	GASKET, OIL FILLER CAP	1	
9#	15625ZE1003	GASKET, OIL FILLER CAP	1	
10	16510ZE2811	GOVERNOR ASSEMBLY (BALANCER) .....	1 .....	INCLUDES ITEMS W/+
11* +	16511ZE2000	WEIGHT, GOVERNOR	2	
12* +	16512ZE2811	HOLDER, GOVERNOR WEIGHT	1	
13* +	16513ZE2000	PIN, GOVERNOR WEIGHT	2	
14*	16531ZE2000	SLIDER, GOVERNOR	1	
15*	90473147000	WASHER (6 X 16)	1	
16*	90602ZE1000	CLIP, GOVERNOR HOLDER	1	
17	90701HC4000	PIN, DOWEL (8 X 12)	2	
18*	58176	WASHER, PLAIN (6MM)	1	
19	957010803500	BOLT, FLANGE (8 X 35)	7	
20*	961006202000	BEARING, RADIAL BALL (6202)	1	
21*	961006204000	BEARING, RADIAL BALL (6204)	1	
22*	961006206000	BEARING, RADIAL BALL (6206)	1	
23*	961006302000	BEARING, RADIAL BALL (6302)	1	



# HONDA GX240K1HA2ENGINE — CRANKSHAFT ASSY.

CRANKSHAFT ASSY.

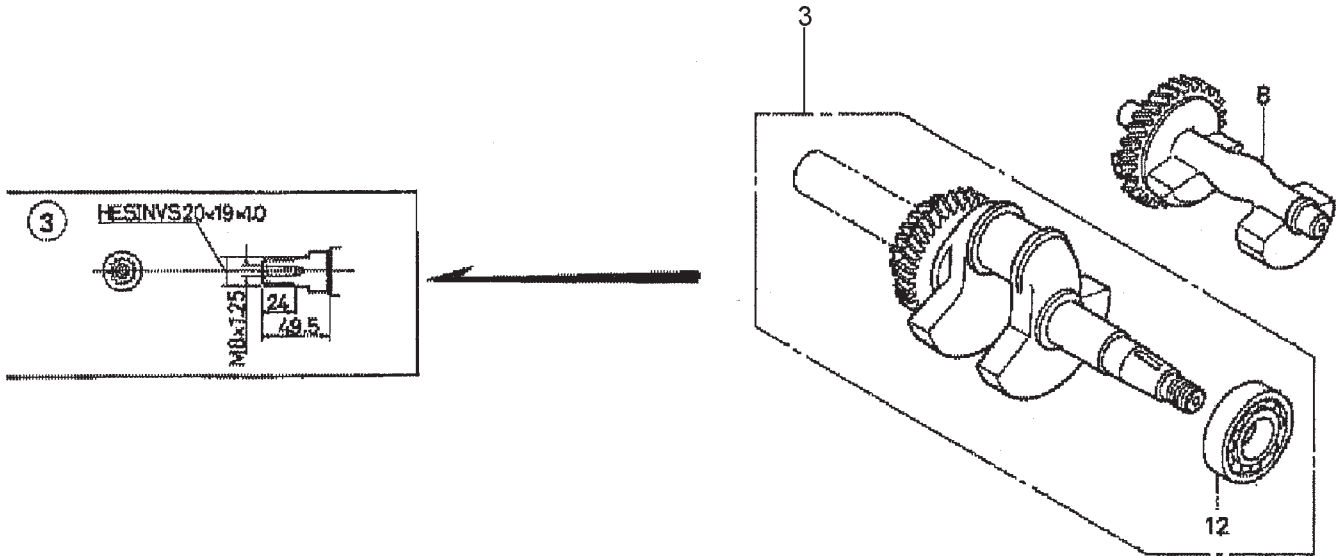

# HONDA GX240K1HA2ENGINE — CRANKSHAFT ASSY.

## CRANKSHAFT ASSY.

<u>NO.</u>	<u>PART NO.</u>	<u>PART NAME</u>	<u>QTY.</u>	<u>REMARKS</u>
3	13320ZE2611	CRANKSHAFT (L-TYPE) .....	1 .....	INCLUDES ITEM W/*
8	13351ZE2010	WEIGHT BALANCER	1	
12*	961006206000	BEARING, RADIAL BALL (6206)	1	

# HONDA GX240K1HA2 ENGINE — CYLINDER BARREL ASSY.

CYLINDER BARREL ASSY.

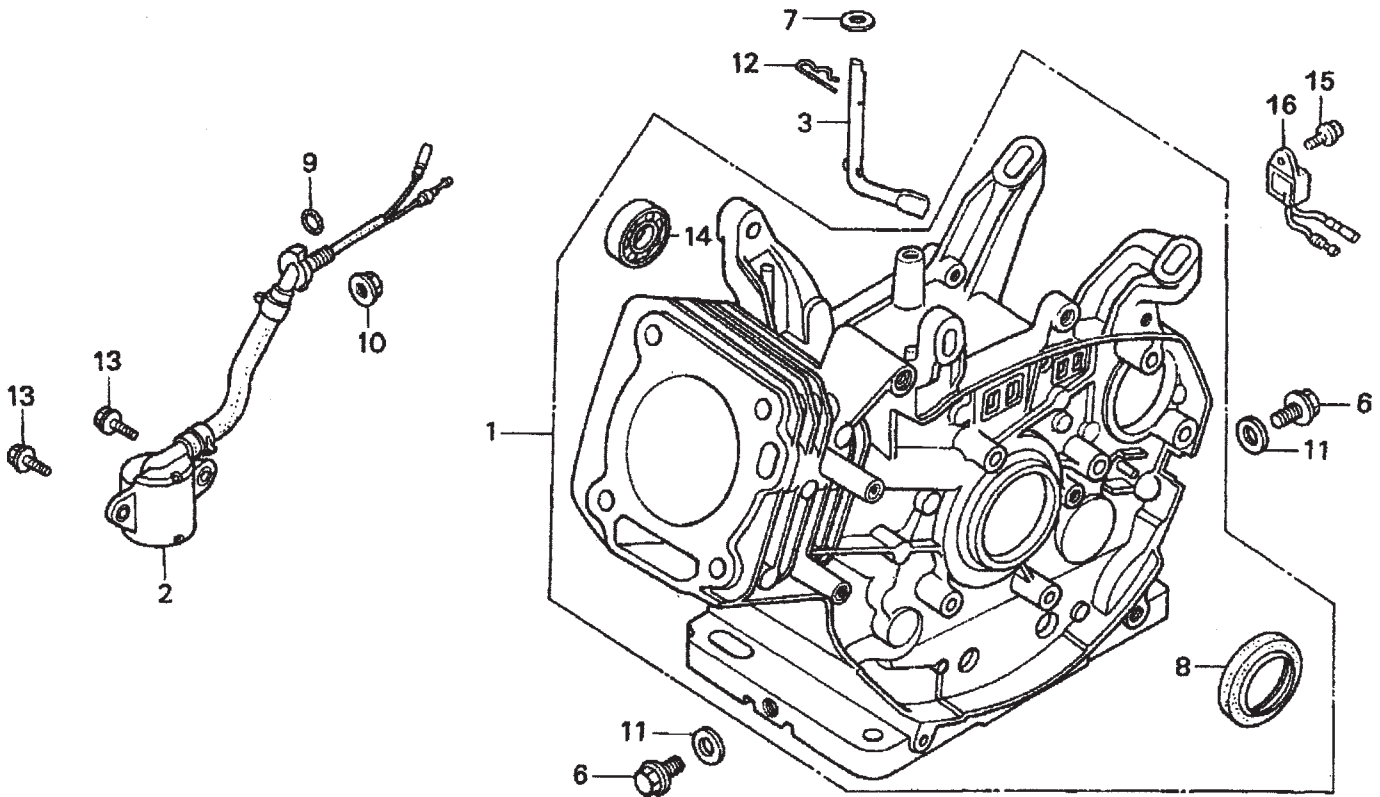

# HONDA GX240K1HA2 ENGINE — CYLINDER BARREL ASSY.

## CYLINDER BARREL ASSY.

<u>NO.</u>	<u>PART NO.</u>	<u>PART NAME</u>	<u>QTY.</u>	<u>REMARKS</u>
1	12000ZE2834	CYLINDER ASSY., BALANCER + OIL ALERT	1	INCLUDES ITEMS W/*
2	15510ZE2043	SWITCH ASSY., OIL LEVEL	1	
3	16541ZE2010	SHAFT, GOVERNOR ARM	1	
6	90131896650	BOLT, DRAIN PLUG	2	
7	90446KE1000	WASHER 8.2 X17X0.8	1	
8*	91201890003	OIL SEAL 30X46X8	1	
9	91353671003	O-RING 14MM ARAI	1	
10	9405010000	NUT FLANGE 10MM	1	
11	031112230	WASHER, DRAIN PLUG 12MM	2	
12	9425110000	PIN, LOCK 10MM	1	
13	957010601200	BOLT, FLANGE 6X12	2	
14*	961006202000	BEARING, RADIAL BALL 6202	1	
15	90013883000	BOLT, FLANGE 6X12 CT200	1	
16	34150ZH7003	ALERT UNIT, OIL	1	

# HONDA GX240K1HA2 ENGINE — CYLINDER HEAD ASSY.

CYLINDER HEAD ASSY.

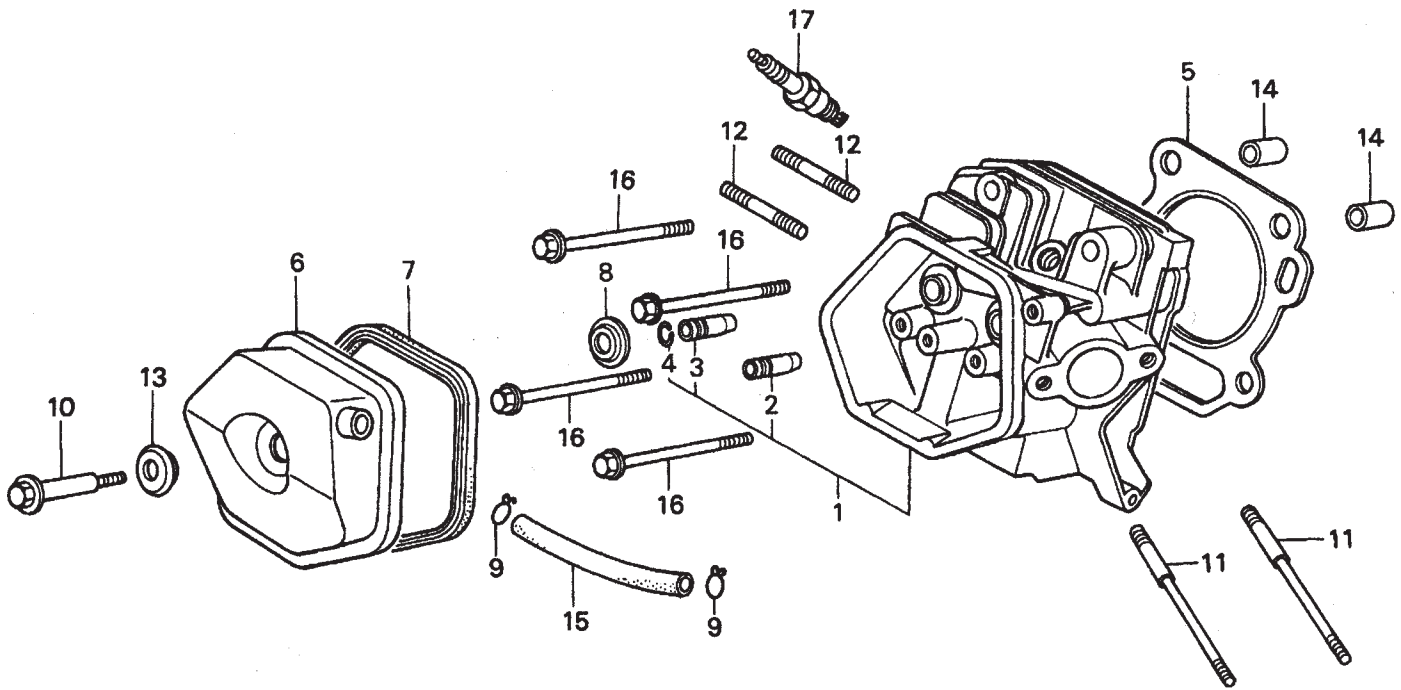

# HONDA GX240K1HA2 ENGINE — CYLINDER HEAD ASSY.

## CYLINDER HEAD ASSY.

<u>NO.</u>	<u>PART NO.</u>	<u>PART NAME</u>	<u>QTY.</u>	<u>REMARKS</u>
1	12200ZH9000	CYLINDER HEAD COMP. ....	1	INCLUDES ITEMS W/*
2*	12204ZE2306	GUIDE, VALVE, OS, OPTIONAL	1	
3*	12205ZE2305	GUIDE, EX. VALVE, OS, OPTIONAL	1	
4*	12216ZE2300	CLIP, VALVE GUIDE	1	
5	12251ZE2800	GASKET, CYLINDER HEAD	1	
6	12310ZE2020	COVER COMP., HEAD	1	
7	12391ZE2020	GASKET, CYLINDER HEAD COVER	1	
8	14775ZE2010	SEAT, VALVE SPRING	1	
10	90014ZE2000	BOLT, HEAD COVER	1	
11	90042ZE2000	BOLT, STUD 8X123	2	
12	92900080320E	BOLT, STUD 8X47	2	
13	90441ZE2010	WASHER COMP., HEAD COVER	1	
14	9430112200	PIN A, DOWEL 12X20	2	
15	950051100130M	BULK HOSE, VACUUM 11X1000, 11X100	1	
16	957011008000	BOLT, FLANGE 10X80	4	
17	9807956846	SPARK PLUG, BPR6ES, NGK	1	
17	9807956855	SPARK PLUG, W20EPR-U, DENSO	1	

# HONDA GX240K1HA2 ENGINE — FAN COVER ASSY.

FAN COVER ASSY.

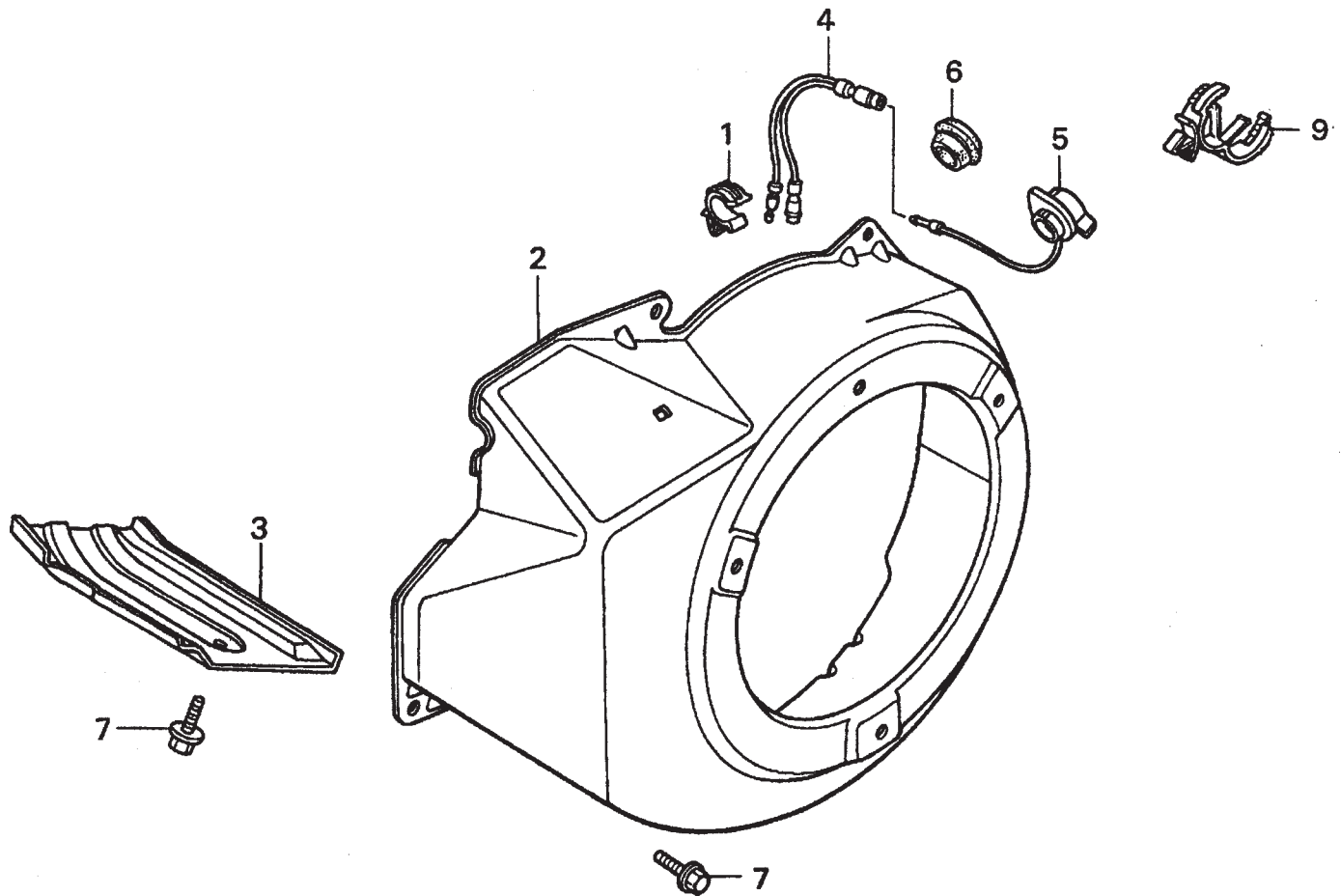

## HONDA GX240K1HA2 ENGINE — FAN COVER ASSY.

FAN COVER ASSY.

<u>NO.</u>	<u>PART NO.</u>	<u>PART NAME</u>	<u>QTY.</u>	<u>REMARKS</u>
1	16731ZE2003	CLIP, TUBE	1	
2	19610ZE2010ZC	COVER COMP., FAN *NH1* BLACK	1	
3	19631ZE2D00	SHROUD	1	
4	32197ZH8003	SUB-HARNESS	1	
5	36100ZE1015	SWITCH ASSY., ENGINE STOP	1	
7	90013883000	BOLT, FLANGE 6X12, CT200	6	
9	90684ZA0601	CLIP, WIRE HARNESS	1	



# HONDA GX240K1HA2 ENGINE — FLYWHEEL ASSY.

FLYWHEEL ASSY.

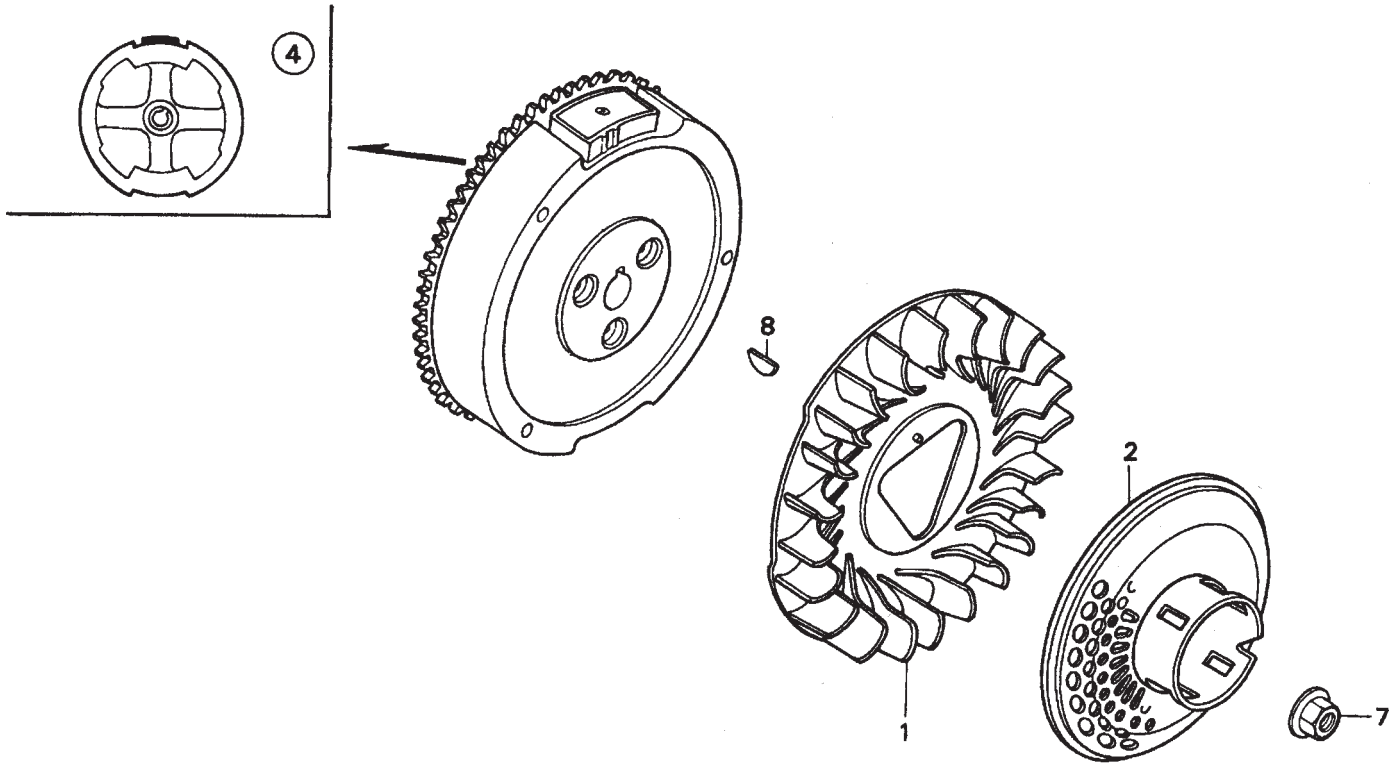

## HONDA GX240K1HA2 ENGINE — FLYWHEEL ASSY.

FLYWHEEL ASSY.

<u>NO.</u>	<u>PART NO.</u>	<u>PART NAME</u>	<u>QTY.</u>	<u>REMARKS</u>
1	19511ZE2000	FAN, COOLING	1	
2	28450ZE2W11	PULLEY COMP., STARTER, SCREEN GRID	1	
4	31100ZE2010	FLYWHEEL COMP.	1	
7	90201ZE3V00	NUT, SPECIAL 16MM	1	
8	90741ZE2000	KEY, SPECIAL WOODRUFF 25X18	1	

# HONDA GX240K1HA2 ENGINE — MUFFLER ASSY.

MUFFLER ASSY.

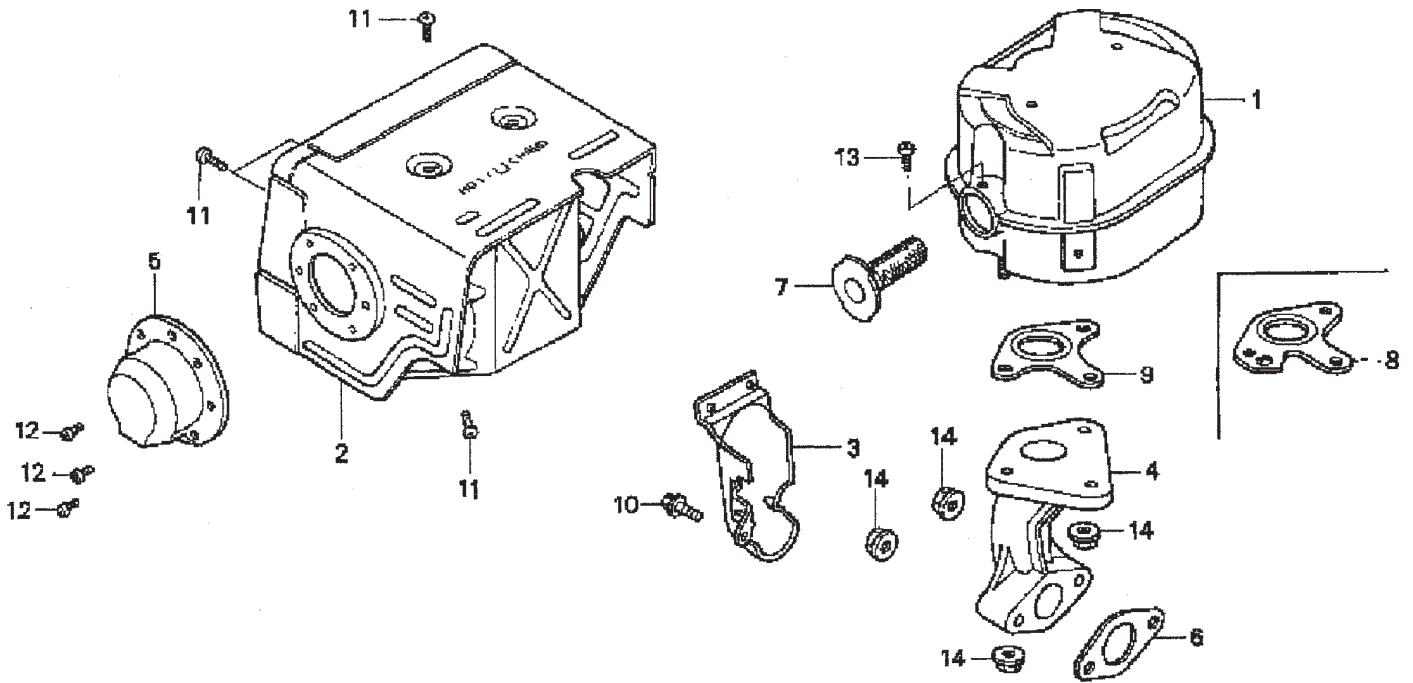

## HONDA GX240K1HA2 ENGINE — MUFFLER ASSY.

### MUFFLER ASSY.

<u>NO.</u>	<u>PART NO.</u>	<u>PART NAME</u>	<u>QTY.</u>	<u>REMARKS</u>
1	18310ZE2W00	MUFFLER	1	
2	18320ZE2W01	PROTECTOR, MUFFLER	1	
3	18323ZE2W00	PROTECTOR, EX. PIPE	1	
4	18330ZE2W00	PIPE, EX.	1	
5	18331ZE2810	CAP, MUFFLER	1	
6	18333ZK6Y00	GASKET, EX. PIPE	1	
7	18355ZE2010	ARRESTER, SPARK	1	
8	18381ZE2W10	GASKET, MUFFLER (ARRESTER)	1	
9	18381ZE2800	GASKET, MUFFLER	1	
10	90013883000	BOLT, FLANGE (6 X 12) (CT200)	1	
11	90050ZE1000	SCREW, TAPPING (5 X 8)	6	
12	90055ZE1000	SCREW, TAPPING (4 X 6)	3	
13	90050ZE1000	SCREW, TAPPING (5 X 8) (OPTIONAL)	1	
14	9405008000	NUT, FLANGE (8MM)	5	



# HONDA GX240K1HA2 ENGINE — FUEL TANK ASSY.

## FUEL TANK ASSY.

<u>NO.</u>	<u>PART NO.</u>	<u>PART NAME</u>	<u>QTY.</u>	<u>REMARKS</u>
1	16854ZH8000	RUBBER SUPPORTER 107MM	1	
2	16955ZE1000	JOINT, FUEL TANK	1	
3	17510ZE2010ZD	TANK COMP., FUEL *NH1*, BLACK	1	
5	17620ZH7023	CAP COMP., FUEL FILLER .....	1	INCLUDES ITEMS W/*
6*	17631ZH7003	GASKET, FUEL FILLER CAP	1	
8	17672ZE2W01	FILTER, FUEL	1	
11	91353671003	O-RING 14MM, ARAI	1	
12	9405008000	NUT, FLANGE 8MM	2	
13	950014500360M	BULK HOSE, FUEL 4.5X3000, 4.5X222	1	
14	9500202080	CLIP, TUBE, B8	2	
15	957010802500	BOLT, FLANGE 8X25	2	

# HONDA GX240K1HA2ENGINE — IGNITION ASSY.

IGNITION COIL ASSY.

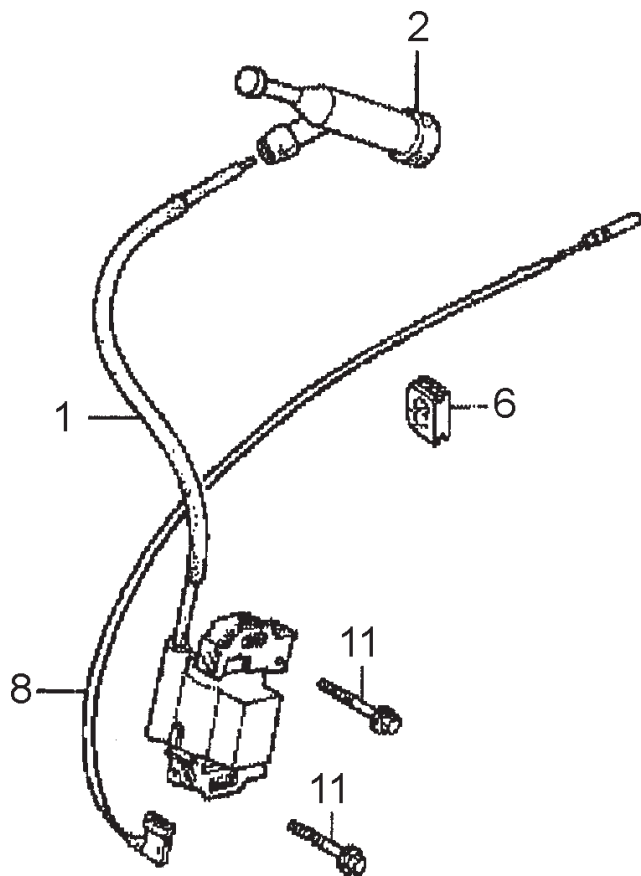

## HONDA GX240K1HA2ENGINE — IGNITION ASSY.

### IGNITION COIL ASSY.

<u>NO.</u>	<u>PART NO.</u>	<u>PART NAME</u>	<u>QTY.</u>	<u>REMARKS</u>
1	30500ZF6W02	COIL ASSY., IGNITION	1	
2	30700ZE1013	CAP ASSY., NOISE SUPPRESSOR	1	
6	31512ZE2000	GROMMET, WIRE	1	
8	36101ZE1010	WIRE, STOP SWITCH 370MM	1	
11	90015883000	BOLT, FLANGE 6X28	2	



**HONDA GX240K1HA2 ENGINE — PISTON ASSY.**

PISTON ASSY.

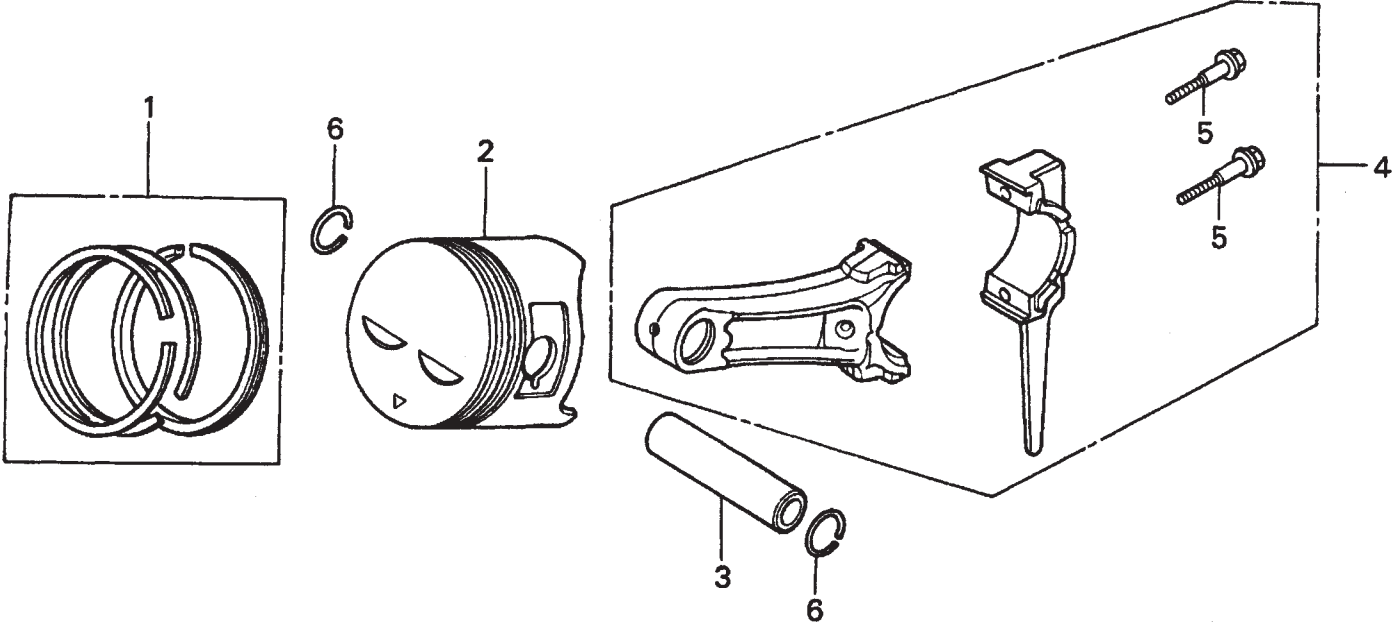

# HONDA GX240K1HA2 ENGINE — PISTON ASSY.

PISTON ASSY.

<u>NO.</u>	<u>PART NO.</u>	<u>PART NAME</u>	<u>QTY.</u>	<u>REMARKS</u>
1	13010ZE2013	RING SET, PISTON, STD.	1	
1	13011ZE2013	RING SET, PISTON, OS 0.25, OPTIONAL	1	
1	13012ZE2013	RING SET, PISTON, OS 0.50, OPTIONAL	1	
1	13013ZE2013	RING SET, PISTON, 0.75, OPTIONAL	1	
2	13101ZE2W00	PISTON, STANDARD	1	
2	13102ZE2W00	PISTON, OS 0.25, OPTIONAL	1	
2	13103ZE2W00	PISTON, OS 0.50, OPTIONAL	1	
2	13104ZE2W00	PISTON, 0.75, OPTIONAL	1	
3	13111ZE2000	PIN, PISTON	1	
4	13200ZE2000	ROD ASSY., CONNECTING STANDARD .....	1	INCLUDES ITEMS W/*
4	13200ZE2305	ROD ASSY., CONNECTING, US 0.25, OPT.	1	
5*	90001ZE8000	BOLT, CONNECTING ROD	2	
6	90551ZE1000	CLIP, PISTON PIN 18MM	2	

# HONDA GX240K1HA2 ENGINE — RECOIL STARTER ASSY.

RECOIL STARTER ASSY.

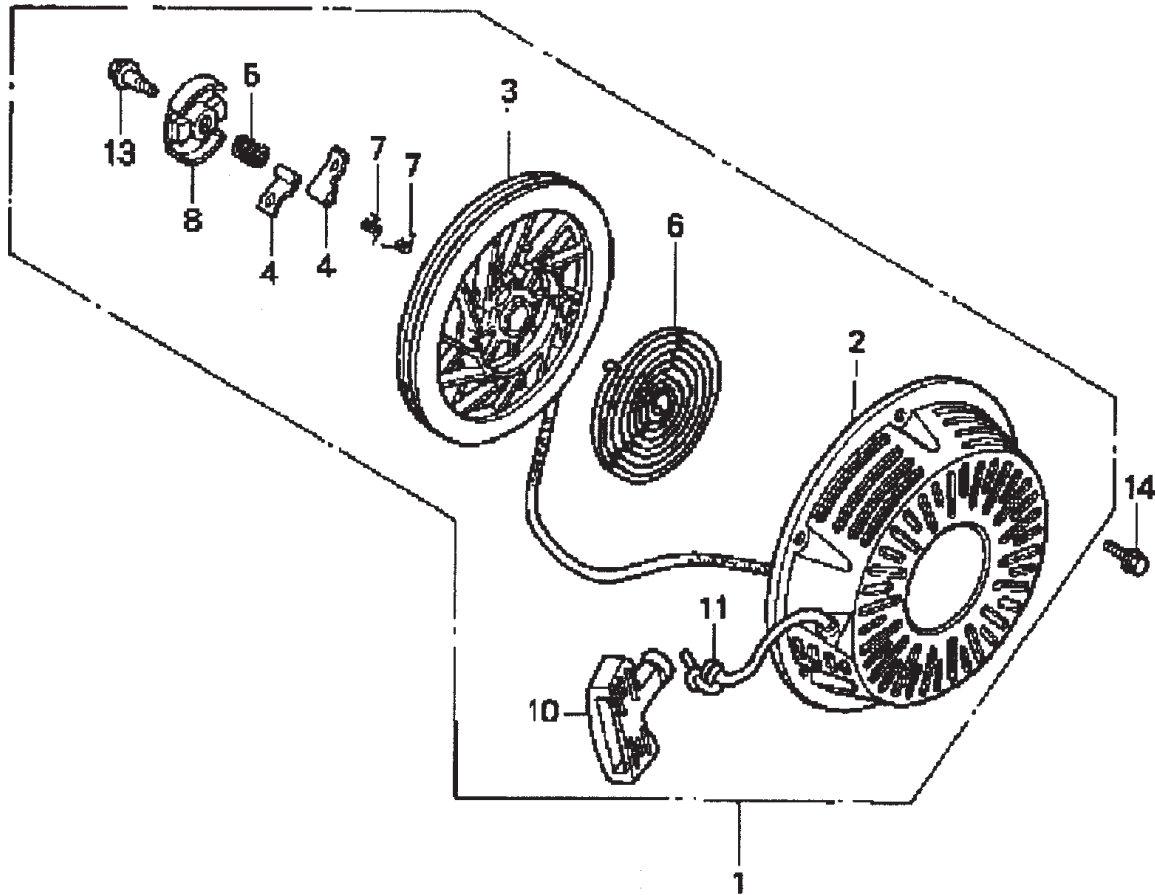

# HONDA GX240K1HA2 ENGINE — RECOIL STARTER ASSY.

## RECOIL STARTER ASSY.

<u>NO.</u>	<u>PART NO.</u>	<u>PART NAME</u>	<u>QTY.</u>	<u>REMARKS</u>
1	28400ZE2W01ZB	STARTER ASSY., RECOIL *NH1*, BLK .....	1 .....	INCLUDES ITEMS W/*
2*	28410ZE2W01ZB	CASE COMP., RECOIL STARTER *NH1*, BLK	1	
3*	28421ZE2W01	PULLEY, RECOIL STARTER	1	
4*	28422ZE2W01	RATCHET, STARTER	2	
5*	28441ZE2W01	SPRING, FRICTION	1	
6*	28442ZE2W01	SPRING, STARTER RETURN	1	
7*	28443ZE2W01	SPRING RATCHET	2	
8*	28444ZE2W01	RETAINER, SPRING	1	
10*	28461ZE2W02	GRIP, STARTER	1	
11*	28462ZE2W11	ROPE, RECOIL STARTER	1	
13*	90004ZE2W01	SCREW, CENTER	1	
14	90008ZE2003	BOLT, FLANGE 6X10	3	

# HONDA GX240K1HA2 ENGINE — GEAR REDUCTION ASSY.

GEAR REDUCTION ASSY.

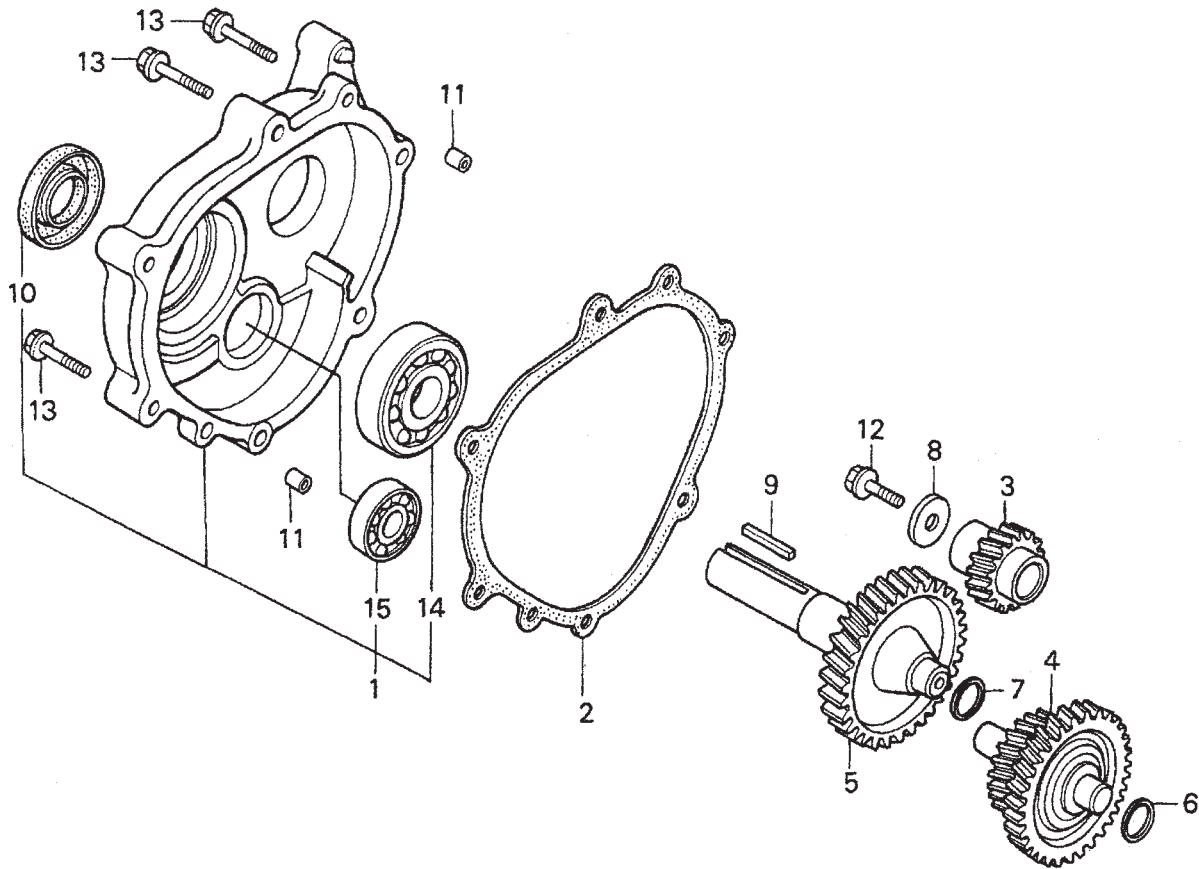

# HONDA GX240K1HA2 ENGINE — GEAR REDUCTION ASSY.

## GEAR REDUCTION ASSY.

<u>NO.</u>	<u>PART NO.</u>	<u>PART NAME</u>	<u>QTY.</u>	<u>REMARKS</u>
1	11500ZE2620	COVER ASSY, REDUCTION CASE .....	1 .....	INCLUDES ITEMS W/*
2	11521ZE2800	GASKET, CHAIN CASE COVER	1	
3	22103ZE2620	GEAR, PRIMARY DRIVE (17T)	1	
4	23220ZE2621	COUNTERSHAFT	1	
5	23710ZE2621	SHAFT, P.T.O. (H- TYPE)	1	
6	90401ZE2620	SHIM A (OPTIONAL)	AR	
7	90402ZE2620	SHIM B (OPTIONAL)	AR	
8	90473842000	WASHER (8MM)	1	
9	90745ZE2600	KEY (6.3 X 6.3 X 43)	1	
10*	91201890003	OIL SEAL (30 X 46 X 8)	1	
11	9430108140	PIN A, DOWEL ( 8 X 14)	2	
12	957010802500	BOLT, FLANGE (8 X 25)	1	
13	957010804000	BOLT, FLANGE (8 X 40)	6	
14*	961006206000	BEARING, RADIAL BALL (6206)	1	
15*	961006302000	BEARING, RADIAL BALL (6302)	1	

# HONDA GX240K1HA2 ENGINE — LABEL ASSY.

LABEL ASSY.

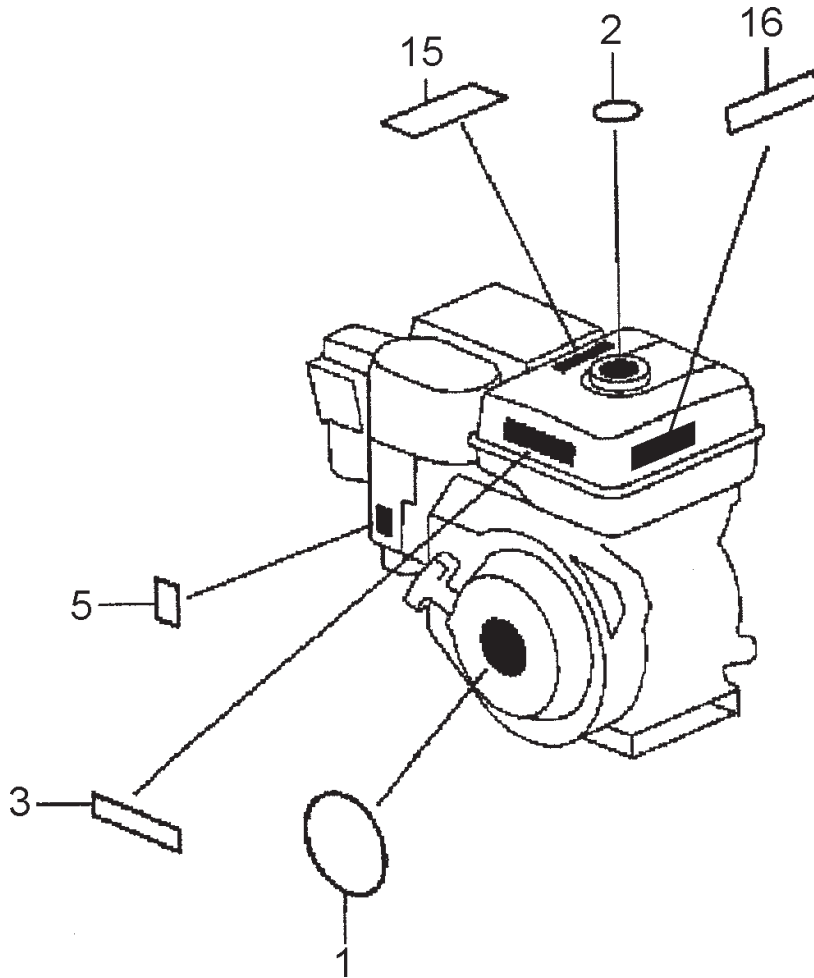

## HONDA GX240K1HA2 ENGINE — LABEL ASSY.

### LABELS ASSY.

<u>NO.</u>	<u>PART NO.</u>	<u>PART NAME</u>	<u>QTY.</u>	<u>REMARKS</u>
1	87521ZE2W01	EMBLEM, INTERNAL	1	
2	87522ZE1810	MARK, CAUTION, EXTERNAL	1	
3	87522ZH9000	LABEL, CAUTION	1	
5	87528ZE2810	MARK, CHOKE, EXTERNAL	1	
15	87586ZH7W00	LABEL, FUEL CAUTION	1	
16	87532ZH8810	MARK, OIL ALERT	1	