

# PARTS MANUAL



## **NIGHTHAWK SERIES MODEL LT12DAB DEDICATED LIGHT TOWER (LOMBARDINI LDW 1003 DIESEL ENGINE)**

Revision #0 (06/03/11)



**THIS MANUAL MUST ACCOMPANY THE EQUIPMENT AT ALL TIMES.**

**PN: 49499**

## SUGGESTED SPARE PARTS

### LT12DAB LIGHT TOWER

1 to 3 units

Qty.	P/N	Description
2.....	200ZG106 .....	Lens Gasket
2.....	190ZQREF .....	Lens
2.....	50Z-D-REF-SUP ..	Support, Lamp Tip
2.....	MVR1000BT37 ....	Bulb
1.....	29798 .....	Ballast & Capacitor 230V, 50Hz
1.....	150Z-E267 .....	Cord Set, 60" w/ 3 Pin Male Plug
1.....	0051475BH .....	Ballast Capacitor 30 $\mu$ F @440V
1.....	GECAP35MF .....	Excitation Capacitor 35 $\mu$ F @425V

### LT12DAB LIGHT TOWER WITH LOMBARDINI LDW 1003 DIESEL ENGINE

1 to 3 units

Qty.	P/N	Description
1.....	2175107 .....	Oil Filter, Lombardini
1.....	2175046.....	Fuel Filter 4-3/4"L
1.....	12850347 ....	Fuel Filter 2-3/4"L
1.....	2175143S ...	Fuel Filter W/Water Drain
1.....	2175164.....	Air Filter
1.....	12850745....	Fan Belt 875mm
1.....	12851312....	Lower Radiator Hose
1.....	12850362....	Upper Radiator Hose
1.....	9195124.....	Thermostat
1.....	12850153....	Thermostat Gasket (O-Ring)
1.....	6585097 .....	Fuel (Feed) Pump
1.....	1200087 .....	Fuel (Feed) Pump Gasket (O-Ring)
1.....	6584438.....	Water Pump
1.....	4580083.....	Water Pump Gasket
1.....	6745056.....	Oil Switch
1.....	12850742....	Alternator
1.....	7245454.....	Electric Panel Control Box
1.....	5840224.....	Starter
1.....	2440338.....	Timing Belt
1.....	5460450.....	Muffler
1.....	4400102.....	Valve Cover Gasket

# NAMEPLATES AND DECALS 1

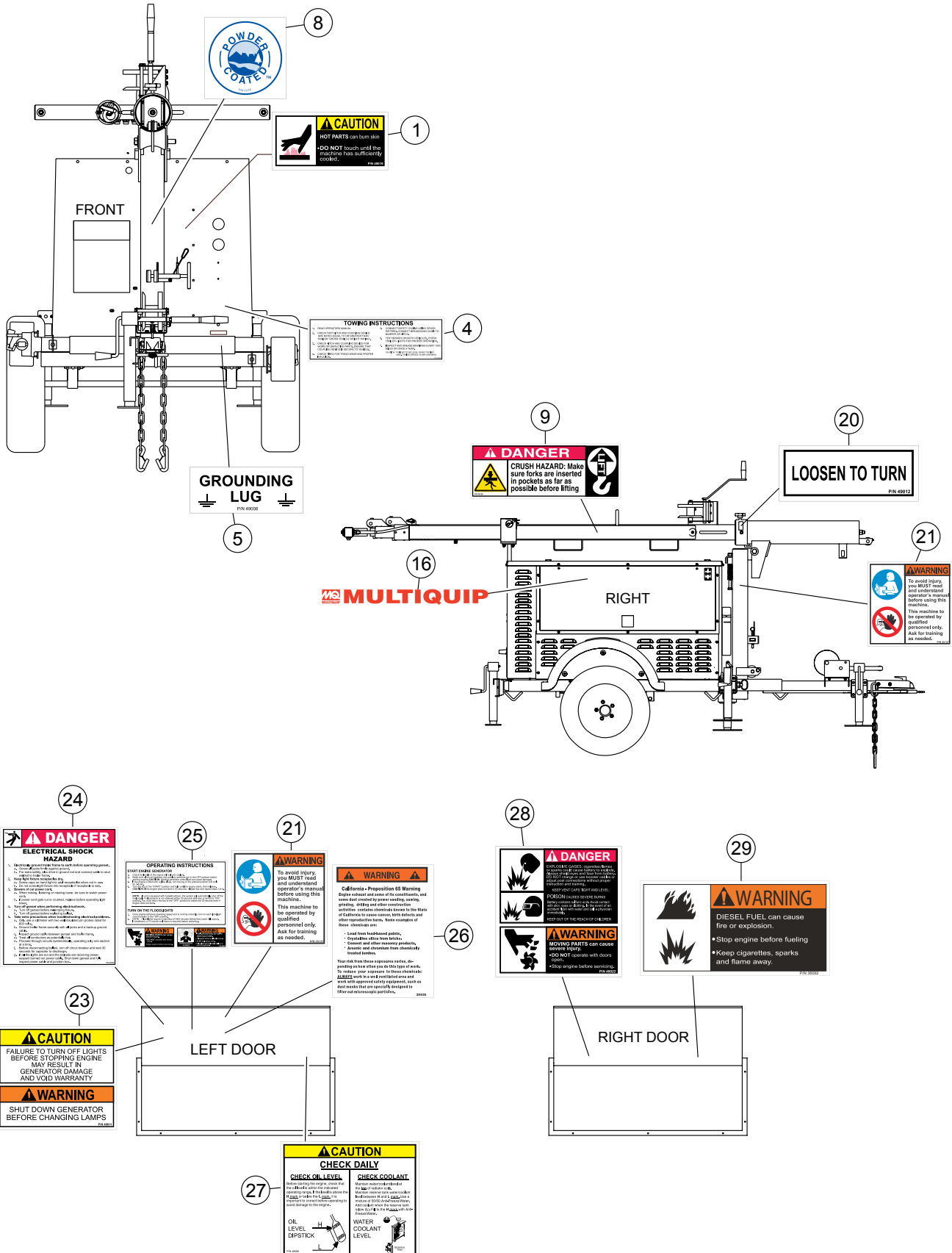

## NAMEPLATES AND DECALS 1

---

<u>NO.</u>	<u>PART NO.</u>	<u>PART NAME</u>	<u>QTY.</u>	<u>REMARKS</u>
1	49019	DECAL, HOT SURFACE	1	
4	49009	DECAL, TOWING INSTRUCTIONS	1	
5	49008	DECAL, GROUND LUG	1	
8	13118	DECAL, POWDER COATED	1	
9	29126	DECAL, INSERT FORKS	1	
16	49026	DECAL, MQ/MULTIQUIP, 36" RED	1	
20	49012	DECAL, LOOSEN TO TURN (MAST)	1	
21	35137	DECAL, READ MANUAL, ASK FOR TRAINING	2	
23	49011	DECAL, LAMPS	1	
24	49020	DECAL, SHOCK HAZARD, LARGE	1	
25	49014	DECAL, OPERATING INSTRUCTIONS	1	
26	20525	DECAL, WARNING "PROP 65", 3.25 X 4.25	1	
27	49006	DECAL, CHECK ENGINE	1	
28	49022	DECAL, DANGER BATTERY/MOVING PARTS	1	
29	36092	DECAL, DIESEL FUEL, 3.5 X 1.75	1	

# NAMEPLATES AND DECALS 2

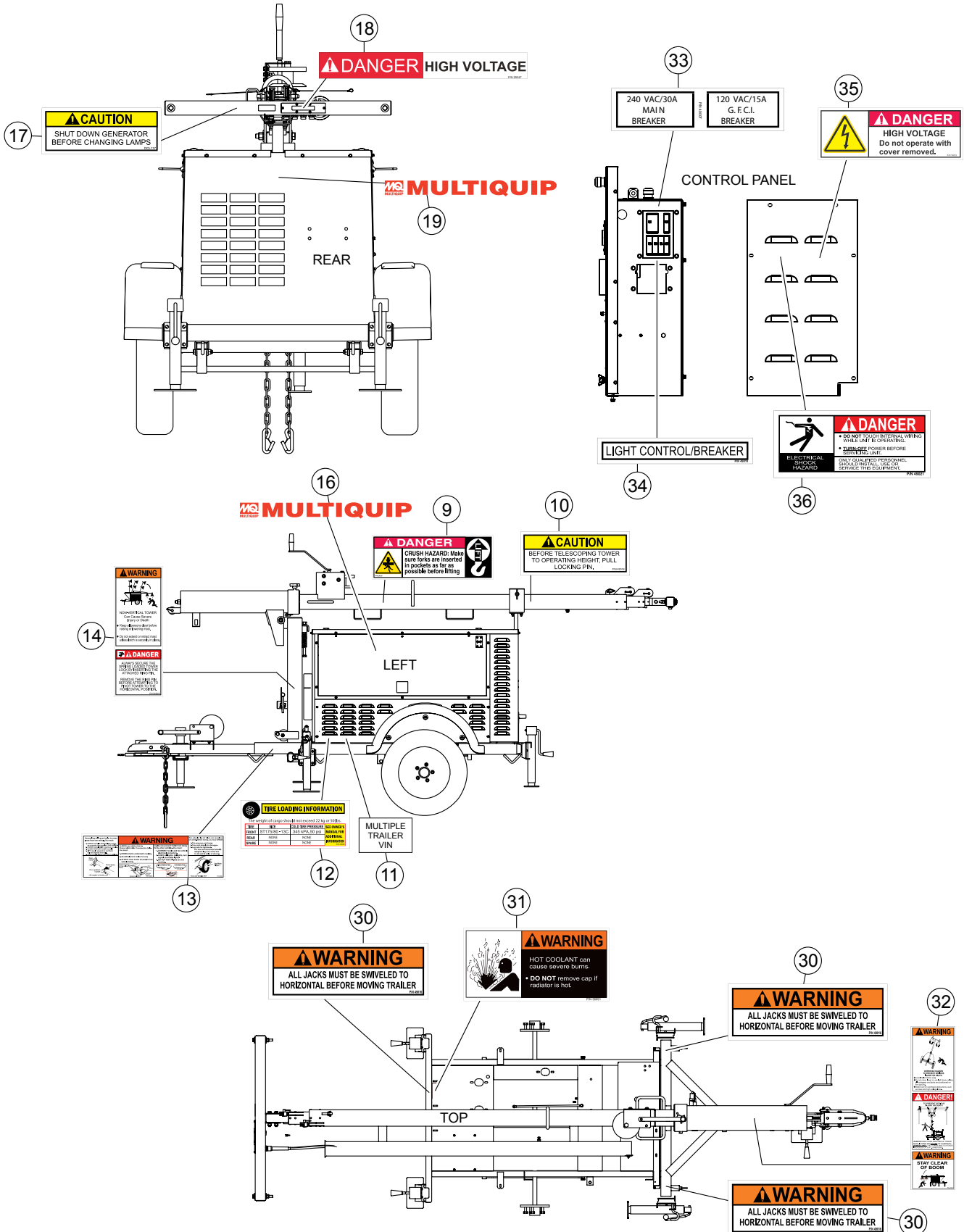

## NAMEPLATES AND DECALS 2

---

<u>NO.</u>	<u>PART NO.</u>	<u>PART NAME</u>	<u>QTY.</u>	<u>REMARKS</u>
9	29126	DECAL, INSERT FORKS	1	
10	49018	DECAL, MAST LOCK PIN	1	
11	29680	DECAL, MULTIPLE TRAILER VIN	1	
12	29838	DECAL, TIRE LOADING, LT12	1	
13	49002	DECAL, TRLR HITCH/WHEEL WARNING	1	
14	49013	DECAL, STANCHION LATCH	1	
16	49026	DECAL, MQ/MULTIQUIP, 36" RED	1	
17	DCL117	DECAL, SHUT DOWN	1	
18	29047	DECAL, HIGH VOLTAGE	1	
19	49027	DECAL, MQ/MULTIQUIP, 30" RED	1	
30	49016	DECAL, HORIZONTAL JACKS	3	
31	36091	DECAL, HOT COOLANT 3.5 X 1.75	1	
32	29651	DECAL, MAST SAFETY	1	
33	49007	DECAL, MAIN BREAKERS	1	
34	49010	DECAL, LIGHT CONTROLS	1	
35	19655	DECAL, DANGER HIGH VOLTAGE	1	
36	49021	DECAL, SHOCK HAZARD, SMALL	1	

# CABINET ASSY.

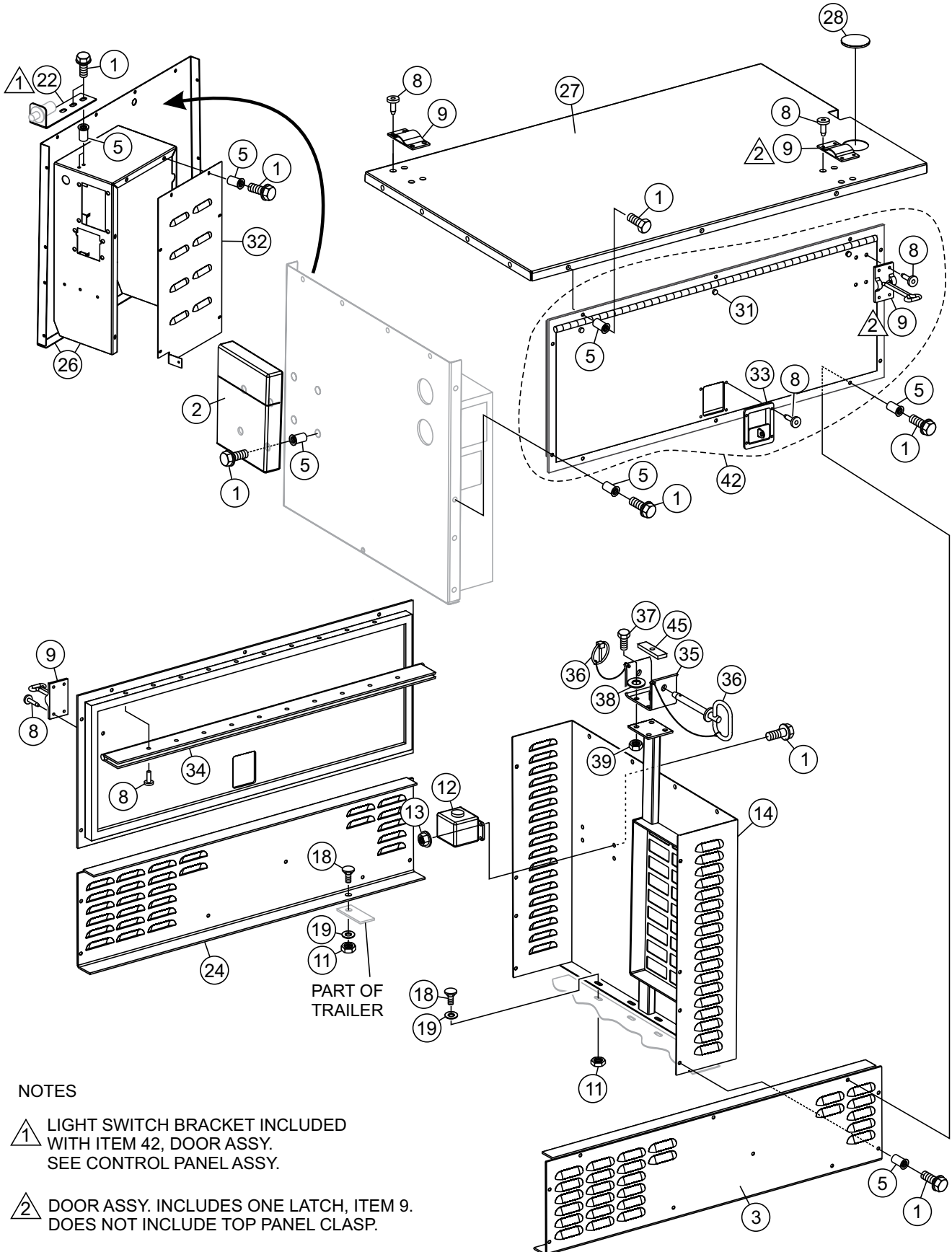

## NOTES

- 1 LIGHT SWITCH BRACKET INCLUDED WITH ITEM 42, DOOR ASSY. SEE CONTROL PANEL ASSY.
- 2 DOOR ASSY. INCLUDES ONE LATCH, ITEM 9. DOES NOT INCLUDE TOP PANEL CLASP.

# CABINET ASSY.

<u>NO.</u>	<u>PART NO.</u>	<u>PART NAME</u>	<u>QTY.</u>	<u>REMARKS</u>
1	49048	SCREW, HHFS 1/4-20 X 3/4 GR5	50	
2	29057	DOCUMENT BOX, CP20007-07	1	
3	29943	PANEL, LOWER LEFT SIDE	1	
5	19266	NUT, BLIND 1/4-20 X 10GA GRIP	50	
8%	19847	RIVET, POP, ALUM, 3/16 X 1/8-1/4 GRIP	66	
9%	29281	DOOR HOLD BACK ASSY.	4	
11	10024	NUT, NYLOC 1/4-20	6	
12	29653	TANK, COOLANT RECOVERY 1 QT	1	
13	10024	NUT, NYLOC 1/4-20	4	
14@	29976	PANEL, REAR	1	
18	29712	BOLT, CARRIAGE 1/4-20 X 3/4	6	
19	0948	WASHER, FLAT SAE 1/4	6	
22%	29607	BRACKET, LIGHT SWITCH	1	
24	29942	PANEL, LOWER RIGHT SIDE	1	
26	49084	PANEL, FRONT//ELECTRICAL ENCLOSURE, SNAP	1	
27	29555	PANEL, TOP	1	
28	29989	COVER, PLASTIC SNAP 4.0 HOLE	1	
31%	29711	BUMPER, 1/2 DIA. BLACK	6	
32	29879	COVER, BALLAST DLT, SNAP FIT SWITCH	1	
33%	081407053413	LATCH	2	
34%		PIANO HINGE		
35@	29936	MAST SUPPORT	1	
36@	19280	PIN, 5/8" X 6"	1	
37@	1023	SCREW, HHC 3/8-16 X 1-1/4 GR 5	4	
38@	10136	WASHER, FLAT SAE 3/8	4	
39@	10133	NUT, NYLOC 3/8-16	4	
42	49051	DOOR ASSY. ....	2	INCLUDES ITEMS W/%
45@	29946	STOP, MAST SUPPORT, 3/8"	1	



# TRAILER ASSY.

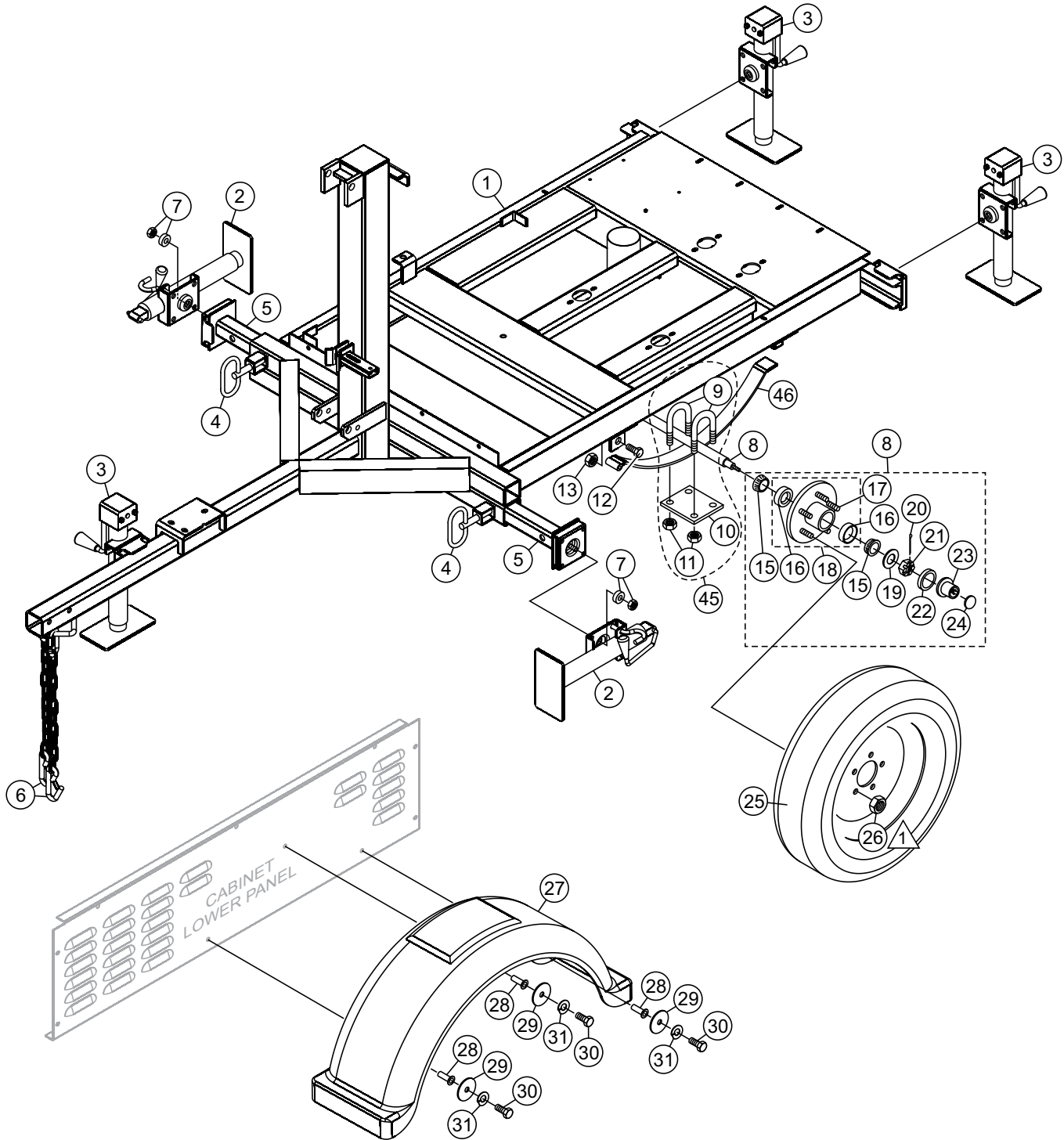

**NOTES:**

▲ TORQUE LUG NUTS PER LUG NUT TORQUE TABLE REFERENCED IN OPERATION MANUAL.

## TRAILER ASSY.

<u>NO.</u>	<u>PART NO.</u>	<u>PART NAME</u>	<u>QTY.</u>	<u>REMARKS</u>
1	49087	FRAME, BUNDED	1	
2	29478	JACK, TOPWIND 10" BOLT-THRU .5 PIN	2	
3	29479	JACK, SIDEWIND 10" BOLT THRU 0.5" PIN	3	
4	29542	PIN, SPRING LOCK, .625" DIA. X .88"	2	
5	49076	OUTRIGGER, W/A, BOLT MOUNT, PAINTED	2	
6	29572	CHAIN ASM, SAFETY 7600 LB	2	
7	7H0933325	BUSHING/LOCKNUT/BOLT	5	
8	9506	AXLE, SPRING,HUB ASSY,43",TRLR10 .....	1	INCLUDES ITEMS W/%
9#		U-BOLT .....	4	NOT SOLD SEPARATELY
10#		PLATE, U-BOLT .....	2	NOT SOLD SEPARATELY
11#		NUT, U-BOLT .....	8	NOT SOLD SEPARATELY
12	29248	SCREW, HHC 9/16-18	2	
13	29249	NUT, 9/16-18 AXLE MOUNTING N-2	2	
15%	363180	BEARING CONE (INNER & OUTER)	4	
16%@	363913	BEARING CUP (INNER & OUTER)	4	
17%@	363908	STUD, 1/2"-20	10	
18%	363188	HUB ASSY., IDLER.....	2	INCLUDES ITEMS W/@
19%	363259	WASHER, SPINDLE	2	
20%	363258	COTTER PIN	2	
21%	363257	SPINDLE NUT 1"-1/4	2	
22%	363275	SEAL, GREASE	2	
23%	363277	GREASE CAP (AG)	2	
24%	568067	RUBBER PLUG (AG)	2	
25	19045	WHEEL/TIRE ST175/80-13 L.R. C	2	
26	29194	NUT, LUG 1/2-20	10	
27	29818	FENDER, PLASTIC DLT	2	
28	19266	NUT, BLIND 1/4-20 X 10GA GRIP	6	
29	10930	WASHER, FENDER, 1/4 X 1-1/4	6	
30	0730	SCREW, HHC 1/4-20 X 1	6	
31	0181 B	WASHER, LOCK 1/4 MED	6	
45	UBK1741	U-BOLT KIT .....	2	INCLUDES ITEMS W/#
46	49017	LEAF SPRING	2	

**MAST ASSY.**

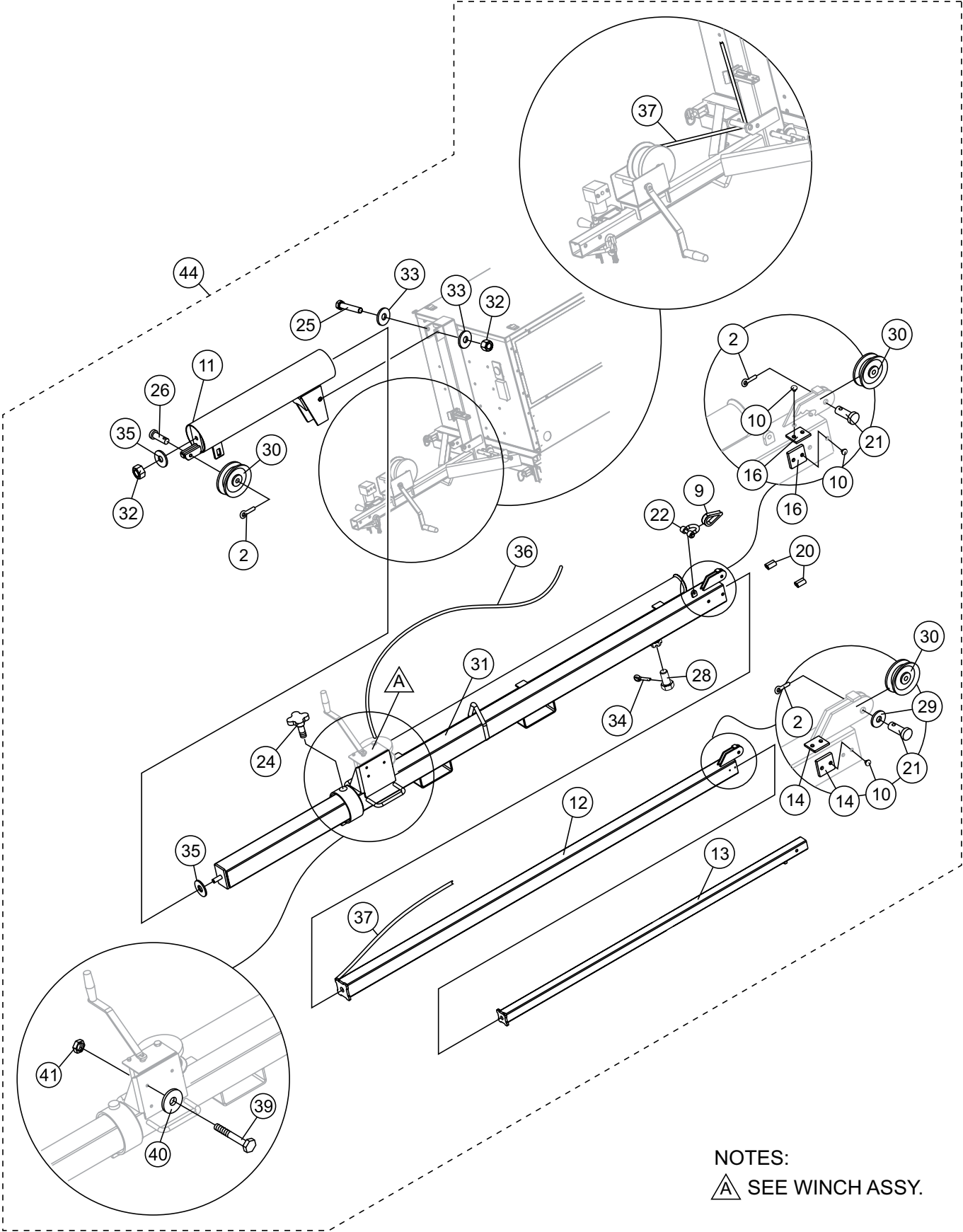

NOTES:  
▲ SEE WINCH ASSY.

# MAST ASSY.

<u>NO.</u>	<u>PART NO.</u>	<u>PART NAME</u>	<u>QTY.</u>	<u>REMARKS</u>
2	0183	PIN, COTTER 1/8D X 1-1/4	3	
9	19200	THIMBLE, 3/16 WIRE	1	
10	19847	RIVET, POP, ALUM, 3/16x1/8-1/4 GRIP	16	
11	19882	SWIVEL, BASE W/A	1	
12	19920	TUBE, TW-MID W/A	1	
13	19923	TUBE, TWR TOP W/A	1	
14	35302	BLOCK, MAST SLIDE, 2 X 2 UPPER	4	
16	35300	BLOCK, MAST SLIDE, 3 X 3 LOWER	4	
20	19973	SWAGE, AL 3/16	2	
21	19974	PIN, CLEVIS 1/2 X 1.25 EFF	2	
22	19975	SHACKLE, ANCHOR CP	1	
24	19977	KNOB, CLAMP 1/2-13 THREAD	1	
25	19978	SCREW, HHC 3/4-10 x 6.5	1	
26	19988	PIN, CLEVIS 1/2 X 1.75 EFF	1	
28	29075	SCREW, HHC 1/2-13 X 1 DRILLED	1	
29	29114	WASHER, FENDER 1/2 x 2 MLT	1	
30	29155	SHEAVE, 2.00 OD X 0.500 ID	3	
31	29941	TUBE, BOTTOM TOWER W/A	1	
32	5070 B	NUT, NYLOC 3/4-10	2	
33	5079	WASHER, FLAT 3/4 USS	3	
34	6014 B	PIN, COTTER 3/32DX1.00	1	
35	8151	WASHER, FLAT SAE 3/4	2	
36	19939	CABLE, LOWER MAST .....	1	.....231 IN. LENGTH
37	19938	CABLE, UPPPER MAST.....	2	..... 140 IN. LENGTH
39	1023	HHC 3/8-16 X 1-1/4 GR5	3	
40	10136	WASHER, FLAT 3/8 SAE	3	
41	21781	NUT, FLANGED 3/8-16 SERRATED, PLATED	3	
44	29650	MAST ASSY.	1	

# MAST RAISE/LOWER ASSY.

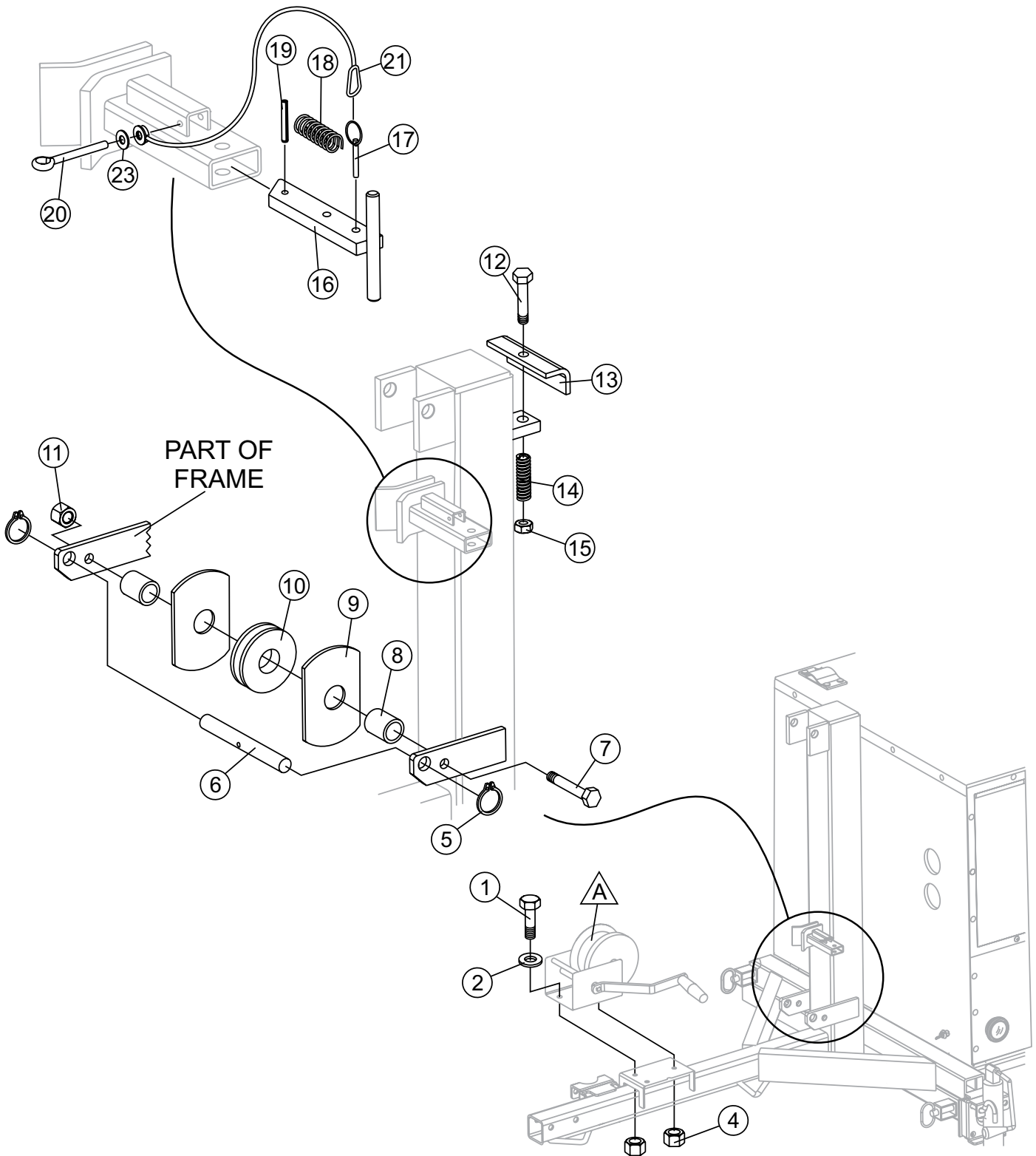

## NOTES:

▲ SEE WINCH ASSY.

## MAST RAISE/LOWER ASSY.

---

<u>NO.</u>	<u>PART NO.</u>	<u>PART NAME</u>	<u>QTY.</u>	<u>REMARKS</u>
1	0205	SCREW, HHC 3/8-16 x 1 IN. PLATED	3	
2	10136	WASHER, FLAT 3/8 IN.	3	
4	21781	NUT, FLANGED 3/8-16 SERRATED, PLATED	3	
5	1135	SNAP RING	2	
6	29008	PIN, SWAGE BALL SOCKET	1	
7	29017	SCREW, HHC 1/2-13 x 5.5 IN.	1	
8	29018	SPACER, .75 OD x .5 ID x 1.59 IN.	2	
9	29016	GUIDE, WIRE ROPE	2	
10	29155	SHEAVE, 2 OD x .5 IN. ID	1	
11	10176	NUT, NYLOC 1/2-13 IN.	1	
12	29077	SCREW, HHC 5/8-11 x 9.5 IN.	1	
13	29481	STOP, MAST THRUST SPRING	1	
14	19989	SPRING, TOWER	1	
15	9503	NUT, NYLOC 5/8-11 IN.	1	
16	29033	TOWER, LOCK	1	
17	19012	LOCK PIN 5/16 x 2 IN. QUICK RELEASE	1	
18	29482	SPRING, .468 OD x 2.13 IN.	1	
19	20276	PIN, ROLL 1/4 x 1.75 IN.	1	
20	0183	PIN, COTTER 1/8D x 1-1/4 IN.	1	
21	19996	LANYARD	1	
23	1450	WASHER, FLAT SAE #6	1	

# WINCH ASSY.

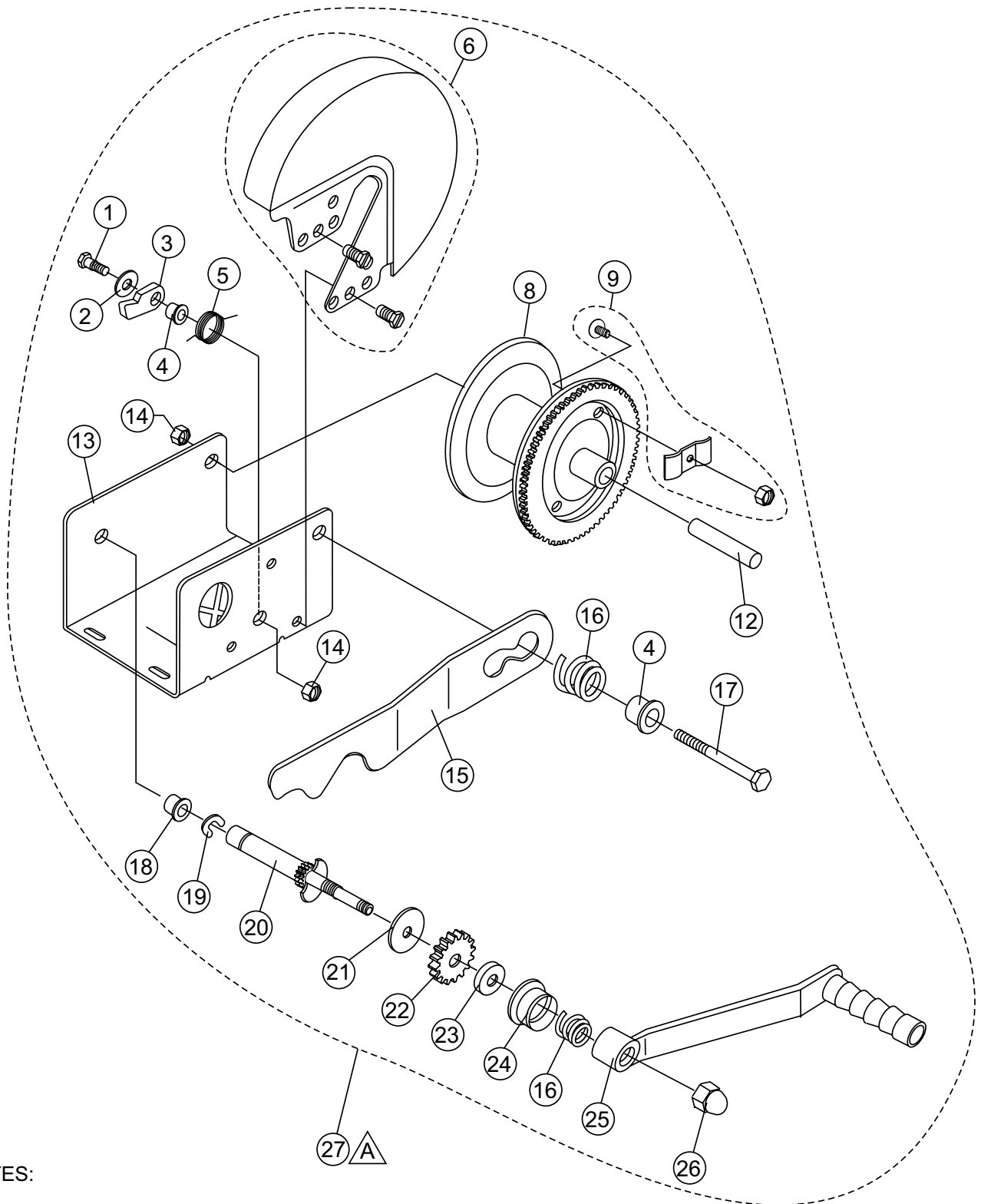

NOTES:

**A** REFER TO MAST AND TRAILER ASSEMBLIES FOR WINCH MOUNTING HARDWARE.

# WINCH ASSY.

<u>NO.</u>	<u>PART NO.</u>	<u>PART NAME</u>	<u>QTY.</u>	<u>REMARKS</u>
1#	DL205167	BOLT	1	
2#	DL205055	WASHER	1	
3#	DL404409	PAWL	1	
4#	DL404166	SPACER	2	
5#	DL204363	SPRING	1	
6#	DL5240387	GEAR COVER, PAINTED BRONZE	1	
6#	DL5240403	GEAR COVER, PLATED	1	
8#	DL304755	REEL	1	
9#	DL304221	ROPE CLAMP KIT	1	
12#	DL204808	REEL SPACER	1	
13#	DL404891	BASE	1	
14#	DL204803	NUT	2	
15#	DL404579	LOCKOUT LEVER	1	
16#	DL204364	SPRING	2	
17#	DL205127	BOLT	1	
18#	DL204009	BUSHING	1	
19#	DL205116	E-RING	1	
20#	DL304760	DRIVE SHAFT	1	
21#	DL204362	PRESSURE PLATE	1	
22#	DL404164	RATCHET WHEEL	1	
23#	DL404163	PRESSURE WASHER	1	
24#	DL206328	BUSHING	1	
25#	29793	HANDLE	1	
26#	DL205033	NUT	1	
27	29790	WINCH ASSEMBLY 1500A D-L.....	1	.....INCLUDES ITEMS W/#



# T-BAR ASSY.

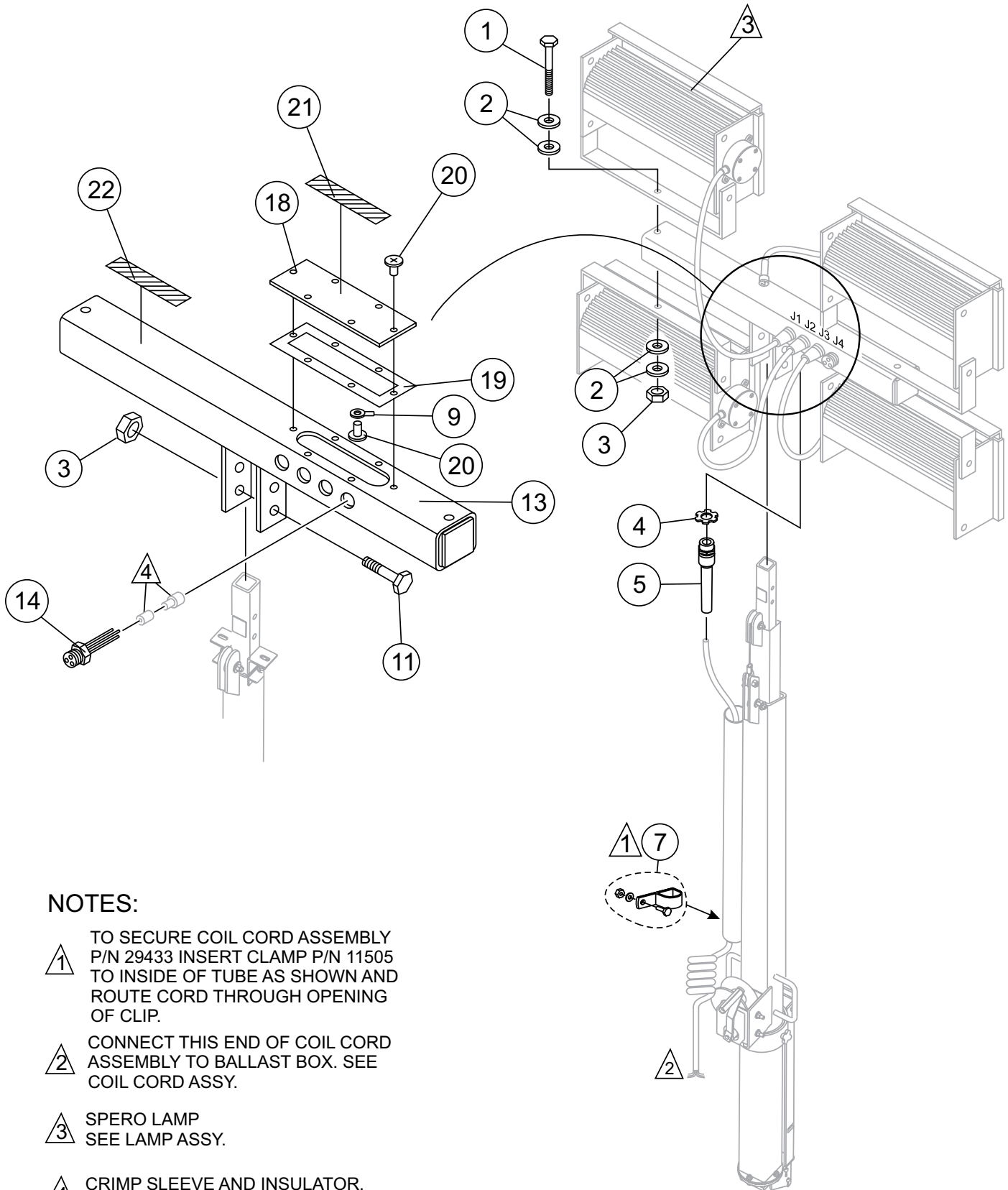

## NOTES:

- 1** TO SECURE COIL CORD ASSEMBLY P/N 29433 INSERT CLAMP P/N 11505 TO INSIDE OF TUBE AS SHOWN AND ROUTE CORD THROUGH OPENING OF CLIP.
- 2** CONNECT THIS END OF COIL CORD ASSEMBLY TO BALLAST BOX. SEE COIL CORD ASSY.
- 3** SPERO LAMP  
SEE LAMP ASSY.
- 4** CRIMP SLEEVE AND INSULATOR.  
SEE COIL CORD ASSY.

## T-BAR ASSY.

---

<u>NO.</u>	<u>PART NO.</u>	<u>PART NAME</u>	<u>QTY.</u>	<u>REMARKS</u>
1	10306	SCREW, HHC 1/2-13 X 4 1/2	2	
2	13211	WASHER, FLAT 1/2 IN. USS	8	
3	10176	NUT, NYLOC 1/2-13	4	
7	11505	CLAMP	1	
9	3254	TERMINAL, RING 16-14 3/8 IN.	1	
11	06503-026	SCREW, HHC 1/2-13 X 3-1/4 IN.	2	
13	29781	TEE-BAR, LIGHT MOUNT, MLT/DLT SPERO	1	
14	29168	RECEPTACLE ASSY	4	
15	19687	CRIMP, SLEEVE (30-410)	7	
16	19688	INSULATOR, SPLICE CAP (2007)	7	
18	19945	PLATE, T-BAR WIRING COVER	1	
19	19944	GASKET, T BAR	1	
20	29046	SCREW, PHPM 10-32 X 3/8 IN. ZINC	7	
21	29047	DECAL, HIGH VOLTAGE	1	
22	19972	REFLECTOR, RED, PETERSON #B491R	1	

**LAMP ASSY.**

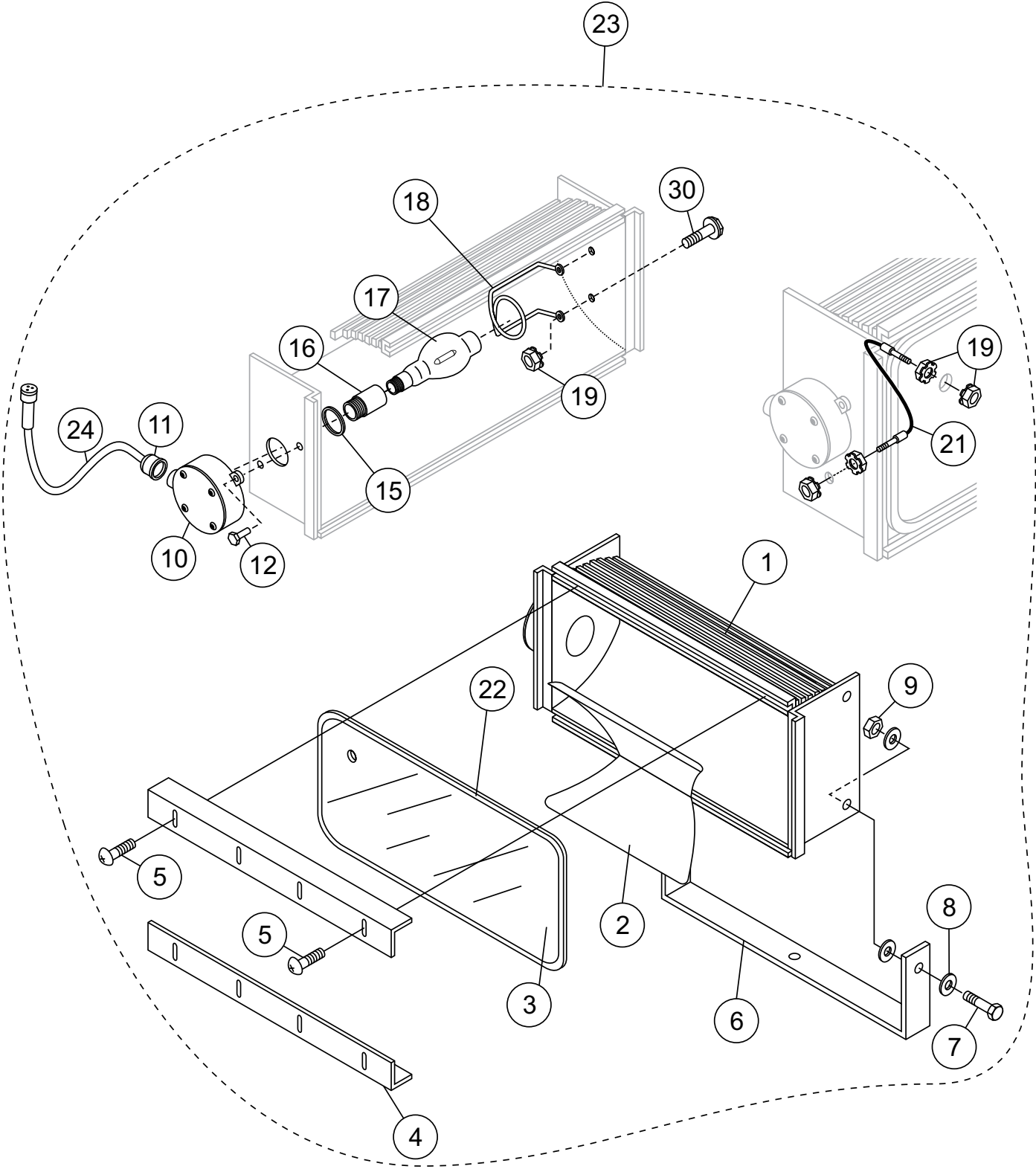

## LAMP ASSY.

<u>NO.</u>	<u>PART NO.</u>	<u>PART NAME</u>	<u>QTY.</u>	<u>REMARKS</u>
1%	20S-REF-1	REF1000 BODY ASSY.	1	
2%	30M-REF-REF	REFLECTOR, ALUMINUM 14-7/8 X 16-5/8 IN.	1	
3%	190ZQREF	REF 1000 LENS 190ZQREF	1	
4%	170M-REF-5	REF LENS HOLD DOWN	2	
5%	70Z-FSCR3	SCREW 8-32 X 1/2 IN.	8	
6%	250-REF-6	YOKE, LIGHT FIXTURE	1	
7%	260Z-FSCR9	BOLT, HEX HEAD 1/2-13 x 1-1/2 IN.	2	
8%	280Z-FWFL2	WASHER, FLAT 1/2 IN.	4	
9%	270Z-FNT4	NUT, HEX 1/2-13 IN.	2	
10%	Z-C-239	VAPORTITE OCTAGON BOX 1/2 IN. W/4 THREADED PLUGS G9 SILVER	1	
11%	150Z-FSR3	STRAIN RELIEF SRW 1/2 IN. BLACK	1	
12%	Z-FSCR9	BOLT, HEX HEAD ZINC PLATED 1/2-13 X 1-1/2 IN.	2	
15%	90Z-G-102	GASKET, HEX #5 OR #6	1	
16%	70Z-SK65	MOGUL SOCKET W/ANTI-VIBRATION GASKET	1	
17%	MVR1000BT37	BULB, LIGHT FIXTURE	1	
18%	50Z-D-REF-SUP	SUPPORT, REF1000 LAMP TIP	1	
19%	230Z-FNTL6-1	KEEP NUT 8-32	6	
21%	210S-CBL-6	CABLE ASSEMBLY	1	
22%	200ZG106	GASKET, U-CHANNEL REFLECTOR 200ZG106	1	
23	29773	LIGHT FIXTURE ASSY.....	1	INCLUDES ITEMS W/%
24%	150Z-EZ67	POWER CORD, 60" W/ 3-PIN MALE PLUG	1	
30%	4106781000	SCREW, 8-32 X 3/8	2	

# CONTROL PANEL/BALLAST ASSY.

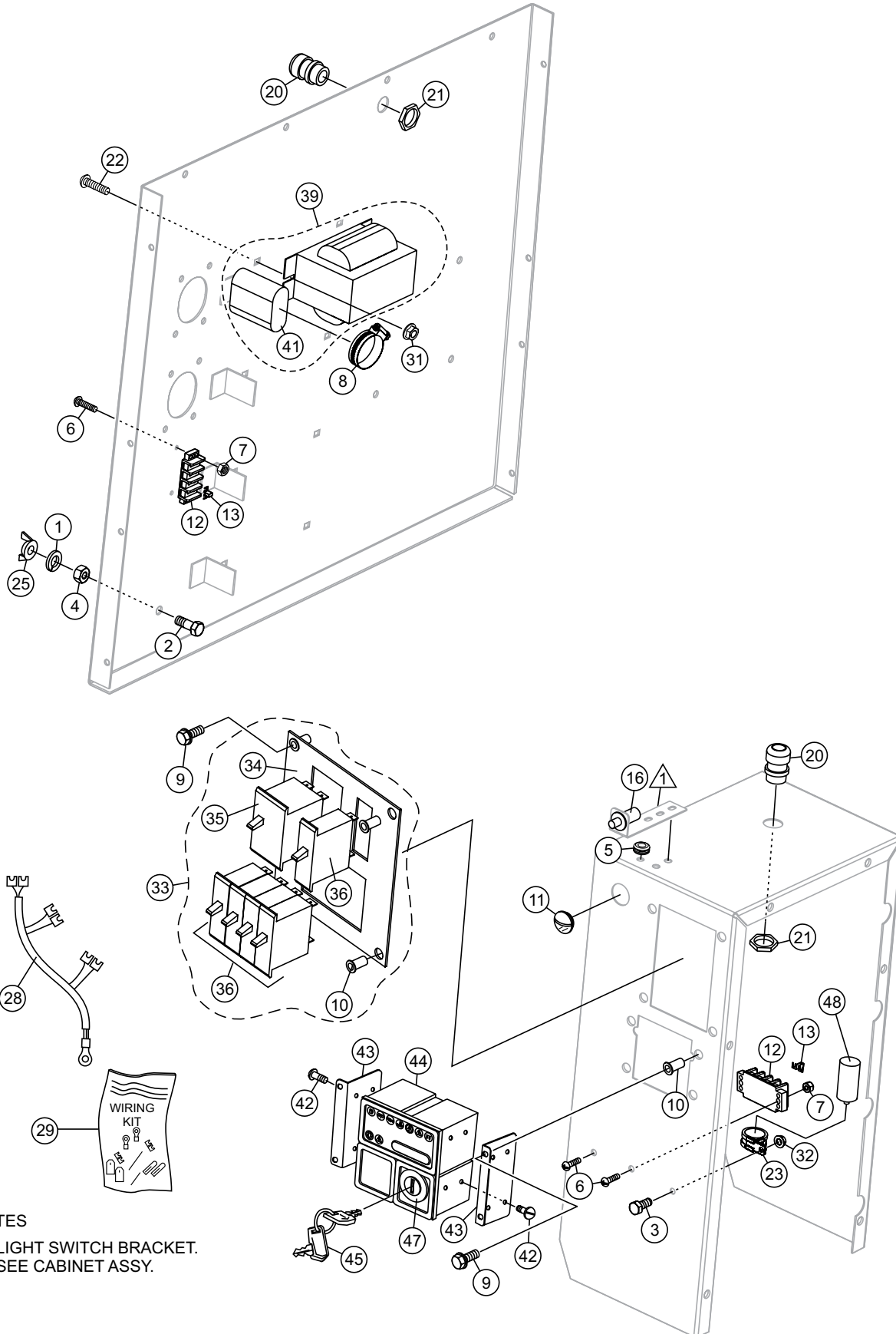

**NOTES**

▲ LIGHT SWITCH BRACKET.  
SEE CABINET ASSY.

## CONTROL PANEL/BALLAST ASSY.

<u>NO.</u>	<u>PART NO.</u>	<u>PART NAME</u>	<u>QTY.</u>	<u>REMARKS</u>
1	0166 A	WASHER, LOCK, 3/8 MED.	1	
2	0205	SCREW, HHC 3/8-16 X 1 PLATED	1	
3	06500-007	SCREW, HHC 5/16-18x7/8	1	
4	1876	NUT, HEX FINISH 3/8-16	1	
5	2574	GROMMET, 5/16" ID 7/16" OD	1	
6	8133	SCREW, PHP 10-32 X 3/4	4	
7	10019	NUT, NYLOC 10-32	4	
8	12277	CLAMP, HOSE WORM 1-9/16 TO 2 SIZE 32	4	
9	49048	SCREW, HHFS 1/4-20 X 3/4 G5	8	
10%	19266	NUT, BLIND 1/4-20 X 10 GA	8	
11	19297	LIGHT, PETERSON MFG V438	1	
12	19968	TERMINAL BLOCK ( DC 70014 )	2	
13	29071	CONNECTOR, QUICK SCREW TERMINAL	4	
16	29603	SWITCH, MOMENTARY	1	
20	29655	FITTING, STRAIN RELIEF HEYCO 3234	2	
21	29656	LOCKNUT, NYLON	2	
22	29712	BOLT, CARRIAGE 1/4-20 X 3/4	8	
23	29796	CLAMP, CUSHIONED LOOP, 1-3/4 DIA X1	1	
25	W29109	NUT, WING 3/8-16	1	
28	49052	HARNESS, LT12 50 CONTROL (AC)	1	
29	29846	WIRING KIT, SWITCH LT SA	1	
31	49070	NUT, FLANGED 1/4-20 SERATED PLTD	8	
32	5283	NUT, NYLOC 5/16-18	1	
33	29865	SNAP SWITCH PLATE ASSY.....	1	INCLUDES ITEMS W/%
34%	29864	SNAP FIT SWITCH INSERT	1	
35%	29848	CIRCUIT BREAKER, 2 POLE, 30A SNAP FIT	1	
36%	29847	CIRCUIT BREAKER, 1 POLE, 15A SNAP FIT	5	
39	29798	BALLAST AND CAPACITOR, 230V 50 HZ.....	4	INCLUDES ITEMS W/@
41@	0051475BH	BALLAST CAPACITOR 30µF @440V	4	
42	29719	SCREW HHC M5-.8 X 8MM PLATED, 8.8 DIN	8	
43	29795	BRACKET, CONTROL PANEL	2	
44	7245454	CONTROL PANEL, LOMBARDINI	1	
45	50404900	KEYS, IGNITION, DOUBLE-SIDED	2	
47	50384401	IGNITION SWITCH	1	
48	GECAP35MF	EXCITATION CAPACITOR 35µF @425V	1	

# FUEL TANK ASSY.

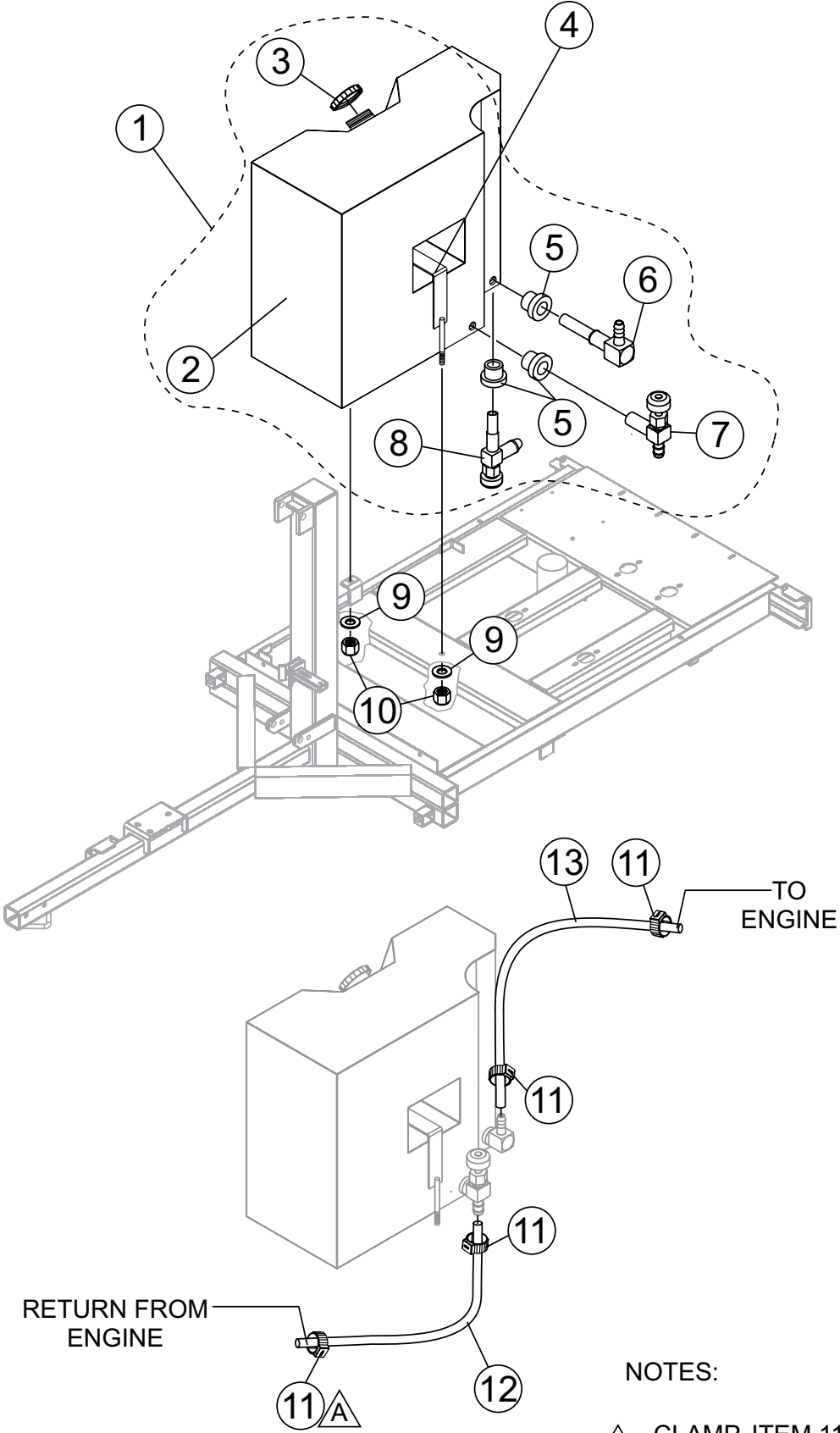

NOTES:

**A** CLAMP, ITEM 11 IS INCLUDED WITH FUEL TANK ASSY. ITEM 1.

## FUEL TANK ASSY.

---

<u>NO.</u>	<u>PART NO.</u>	<u>PART NAME</u>	<u>QTY.</u>	<u>REMARKS</u>
1	29676	FUEL TANK ASSY. ....	1 .....	INCLUDES ITEMS W/#
2#	29605	FUEL TANK	1	
3#	29694	CAP, FUEL TANK W/LANYARD	1	
4	29992	STRAP, FUEL TANK	1	
5#	19633	BUSHING, FUEL	3	
6#	12006	FITTING, 90°	1	
7#	20795	VALVE, SHUTOFF 4MBARB X 6SBARB SCREEN	1	
8#	19661	VALVE, SHUTOFF 5BARB X 6SBARB NO SCREEN	1	
9	13211	WASHER, FLAT 1/2 USS	2	
10	10176	NUT, NYLOCK 1/2-13	2	
11	22066	CLAMP, STEPLESS EAR 3/16 HOSE #123	4	
12	60028	HOSE, FUEL RETURN .312 ID SAE J30R7 AR	1PC = 1 FT.	
13	60004	HOSE, FUEL LINE .187 I.D. SAE J30R7 AR	1PC = 1 FT.	



# BATTERY ASSY.

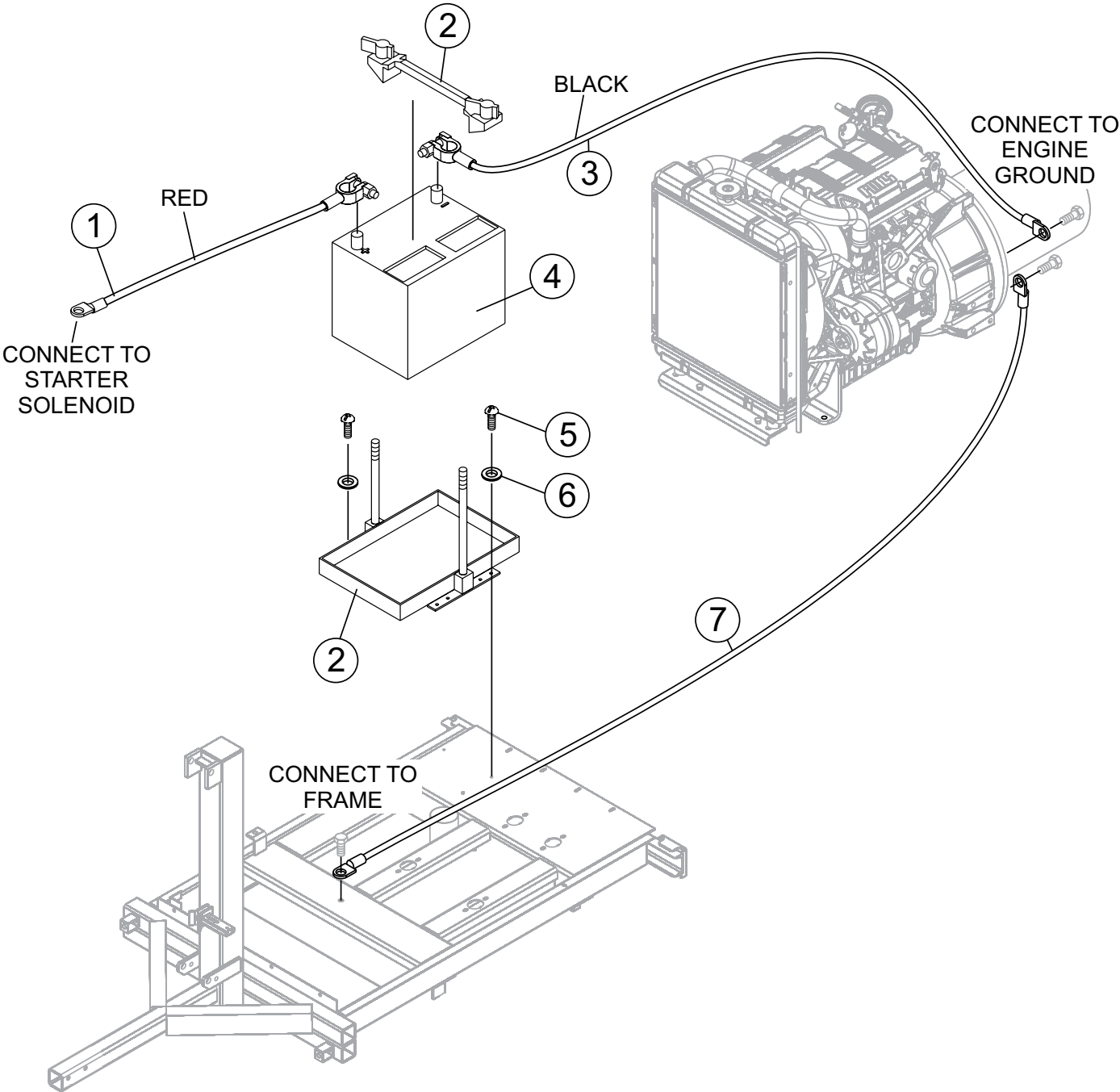

## BATTERY ASSY.

---

<u>NO.</u>	<u>PART NO.</u>	<u>PART NAME</u>	<u>QTY.</u>	<u>REMARKS</u>
1	19303	CABLE, POS. BATTERY (+)	1	
2	29661	BATTERY TRAY	1	
3	12278	CABLE, NEG. BATTERY (-)	1	
4	10315	BATTERY, WET 12V GR22	1	
5	1623	SCREW, RHM #10-24 x .75 IN.	4	
6	2203	WASHER, FLAT #10	4	
7	1597	CABLE, BATTERY	1	

# ENGINE ASSY.

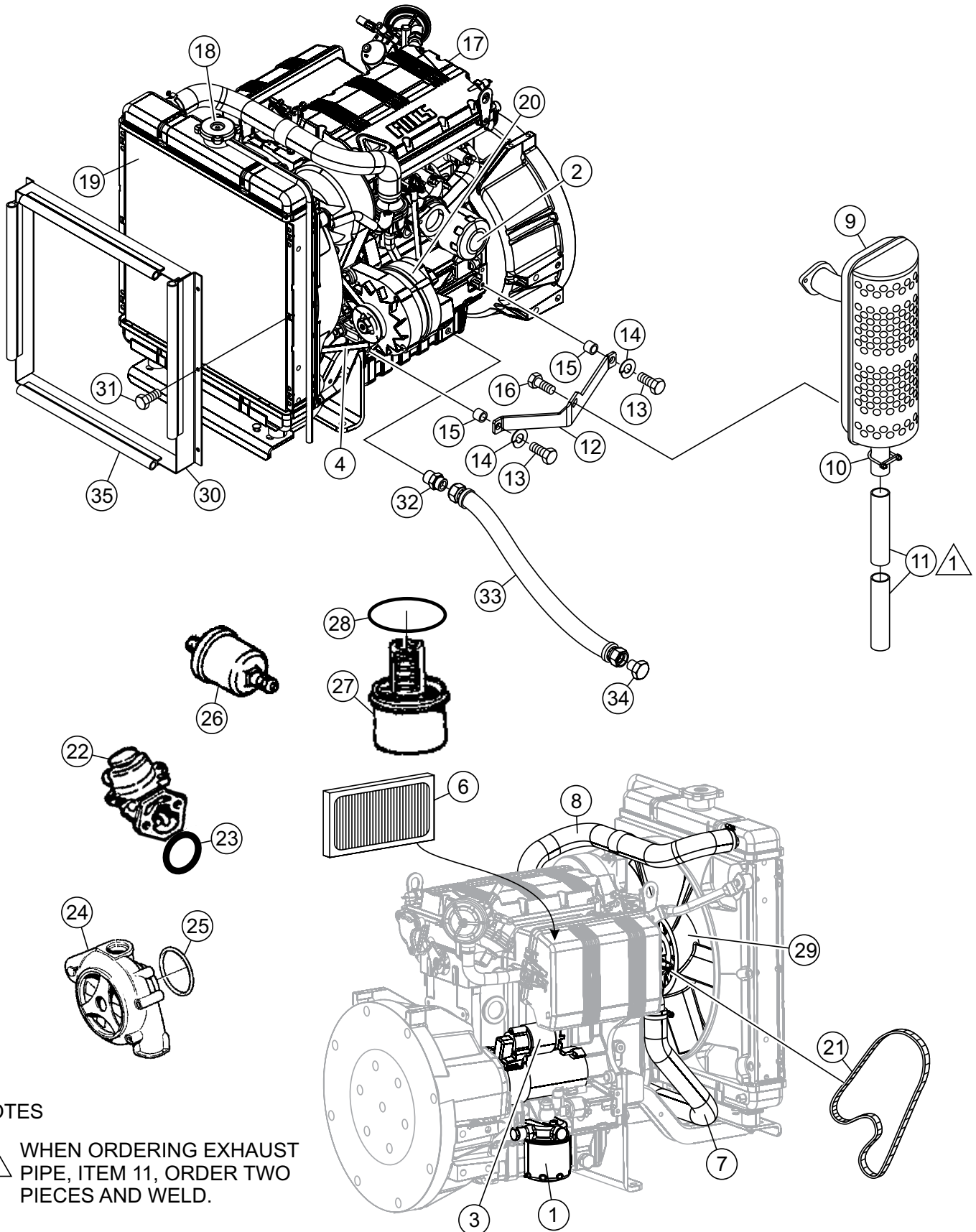

## NOTES

1 WHEN ORDERING EXHAUST PIPE, ITEM 11, ORDER TWO PIECES AND WELD.

## ENGINE ASSY.

<u>NO.</u>	<u>PART NO.</u>	<u>PART NAME</u>	<u>QTY.</u>	<u>REMARKS</u>
1	12850347	FUEL FILTER 2-3/4" L	1	
1	2175046	FUEL FILTER 4-3/4" L	1	
1	2175143S	FUEL FILTER W/WATER DRAIN	1	
2	2175107	OIL FILTER	1	
3	5840224	STARTER	1	
4	12850745	FAN BELT 875MM	1	
6	12851312	AIR FILTER	1	
7	12850362	LOWER RADIATOR HOSE	1	
8	12850649	UPPER RADIATOR HOSE	1	
9	5460450	MUFFLER	1	
10	10855	CLAMP, 1-1/2 MUFFLER	1	
11	29645	EXHAUST PIPE	2	
12	29937	BRACE, LOWER MUFFLER	1	
13	21584	BOLT M10-1.5P X 35MM	2	
14	0161 C	WASHER, LOCK 5/16 MED	2	
15	29938	SPACER, MUFFLER BRACKET, 3/8 X 3/4 X 5/8	2	
16	2299	BOLT, M8-1.25P X 16MM	1	
17	29644	ENGINE, LOMBARDINI LDW1003	1	
18	9000184	RADIATOR CAP	1	
19	7350270	RADIATOR	1	
20	12850742	ALTERNATOR	1	
21	2440338	TIMING BELT	1	
22	6585097	FUEL (FEED) PUMP	1	
23	1200087	GASKET, FUEL (FEED) PUMP)	1	
24	6584438	WATER PUMP	1	
25	4580083	GASKET, WATER PUMP	1	
26	6745056	OIL SWITCH	1	
27	9195124	THERMOSTAT	1	
28	12850153	GASKET, THERMOSTAT	1	
29	12850551	COOLING FAN	1	
30	29994	SHROUD, LT12 RADIATOR	1	
31	12464	SCREW, HHC M6-1.0 X 16MM	6	
32	367681	FITTING, STR 8MJ - M18MO	1	
33	35017	HOSE ASM, 19.9" #8LP w/ 370677	1	
34	366030	FITTING, PLUG 8MJ	1	
35	60124	GASKET, SPONGE BULB (FT)	5	

# GENERATOR/ENGINE MOUNTING ASSY.

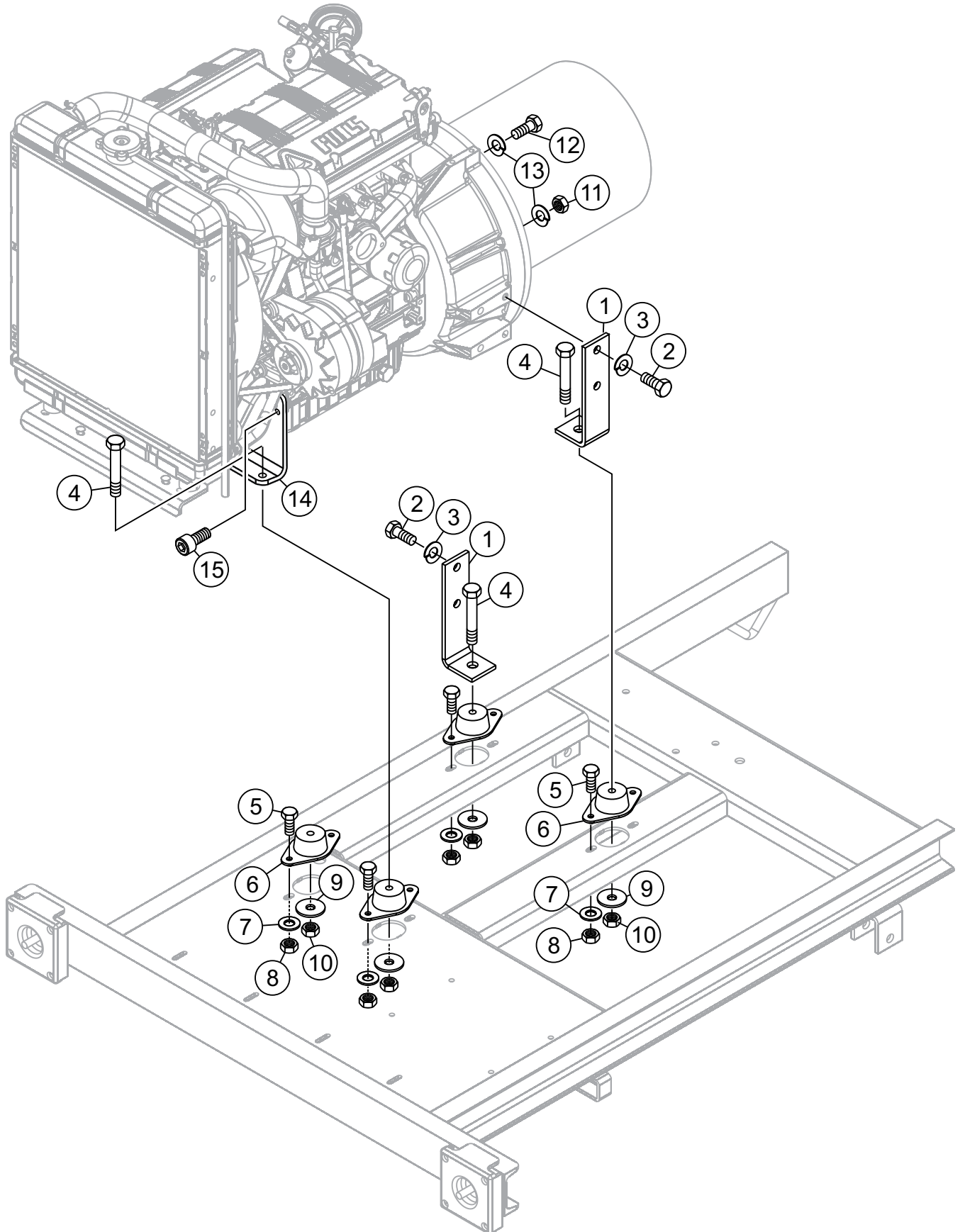

## GENERATOR/ENGINE MOUNTING ASSY.

<u>NO.</u>	<u>PART NO.</u>	<u>PART NAME</u>	<u>QTY.</u>	<u>REMARKS</u>
1	49003	MOUNT, REAR ENGINE	2	
2	17099	SCREW, HHC M12-1.75 X 20 ZN, DIN933	4	
3	5054 A	WASHER, LOCK 1/2 MED	4	
4	8156	SCREW, HHC 3/8-16 X 2 1/2	4	
5	0655	SCREW, HHC 5/16-18 X 3/4	8	
6	29269	MOUNT, VIBRATORY ENGINE	4	
7	19470	WASHER, FLAT 5/16 USS	8	
8	5283	NUT, NYLOC 5/16-18	8	
9	29043-001	WHEEL, POINTER .411Dx2.00OD C.SAW	4	
10	10133	NUT, NYLOC 3/8-16	4	
11	1456	NUT, HEX FINISH 3/8-16	6	
12	1023	SCREW, HHC 3/8-16 X 1 1/4 GR 5	8	
13	0166 A	WASHER, LOCK, 3/8 MED.	14	
14		MOUNT, FRONT ENGINE.....	1	SUPPLIED BY VENDOR
15		SCREW .....	2	SUPPLIED BY VENDOR

**GENERATOR ASSY.**

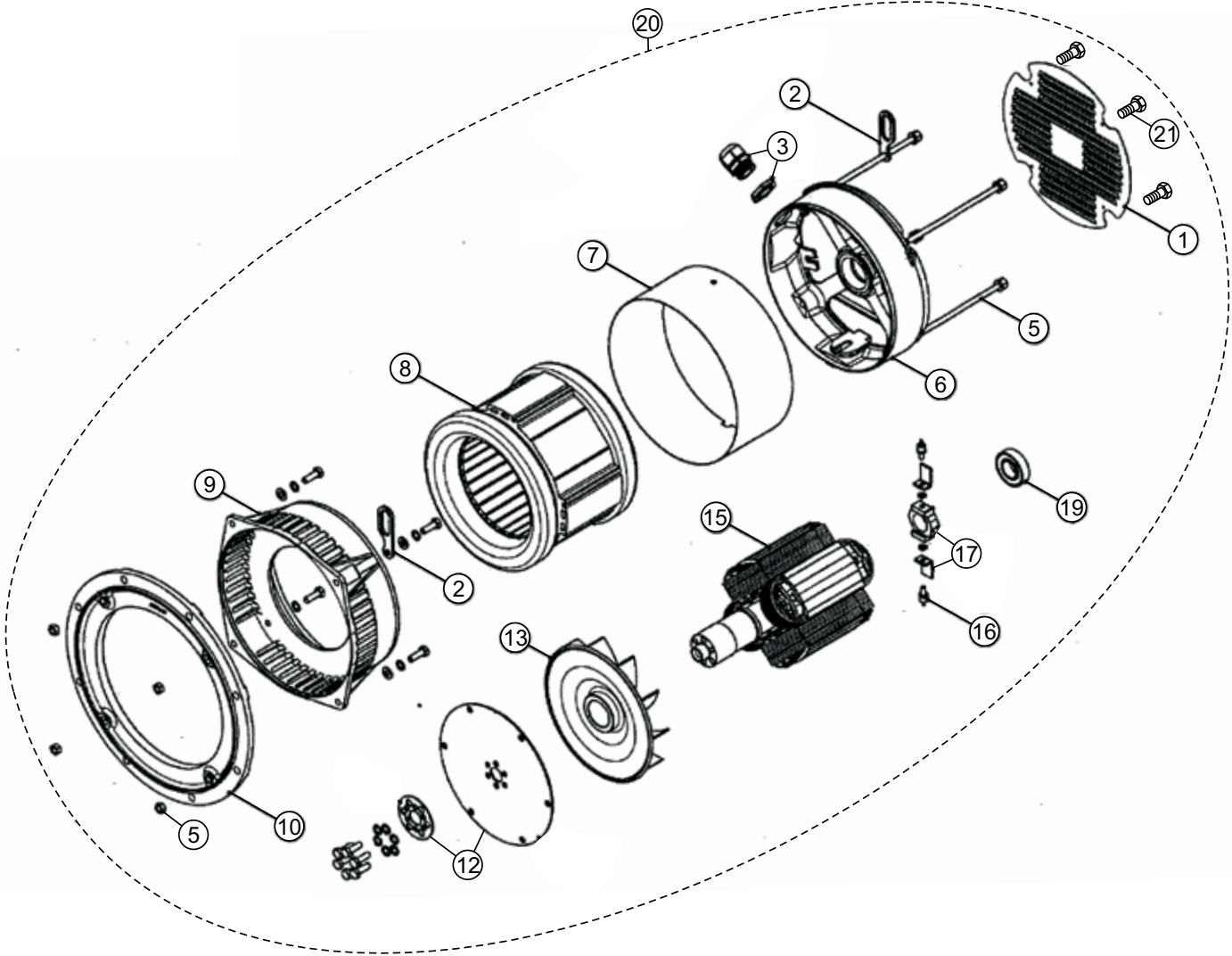

## GENERATOR ASSY.

<u>NO.</u>	<u>PART NO.</u>	<u>PART NAME</u>	<u>QTY.</u>	<u>REMARKS</u>
1%	GELT3GRID	REAR SEAL	1	
2%	GELT3LIFTHK	LIFTING HOOK	2	
3%	GELT3CABLEGPG21	PG21 CABLE GLAND AND NUT	1	
5%	GELT3CSBOLTS	COVER STAY BOLT AND NUT	4	
6%	GELT3NDEBRACKET	NON-DRIVE END BRACKET	1	
7%	GELT3110ENCBAND	ENCLOSING BAND	1	
8%	GELT3110STATOR50	WOUND STATOR AND FRAME	1	
9%	GELT3DEBRACKET	DRIVE END BRACKET	1	
10%	6102208193	INTERCHANGEABLE FLANGE	1	
12%	GEECO3DISC65	FLEXIBLE DISC AND RING SPACER	1	
13%	GELT3FAN	FAN	1	
15%	GELT3110ROTOR50	ROTOR ASSY	1	
16%	GEDIO160026	DIODES	2	
17%	GELT3DIOHSINK	HEAT SINK/SUPPORT, ROTATING DIODE BRIDGE	2	
19%	GEBRG6205LL	REAR BEARING 6205-2RS	1	
20	49126	GENERATOR LT3-110/4, 50 HZ.....	1	.....INCLUDES ITEMS W/%
21%	29895SCREW	COVER SCREWS, SET OF 3	1	



# COIL CORD ASSY.

CONNECT TO T-BAR ASSEMBLY

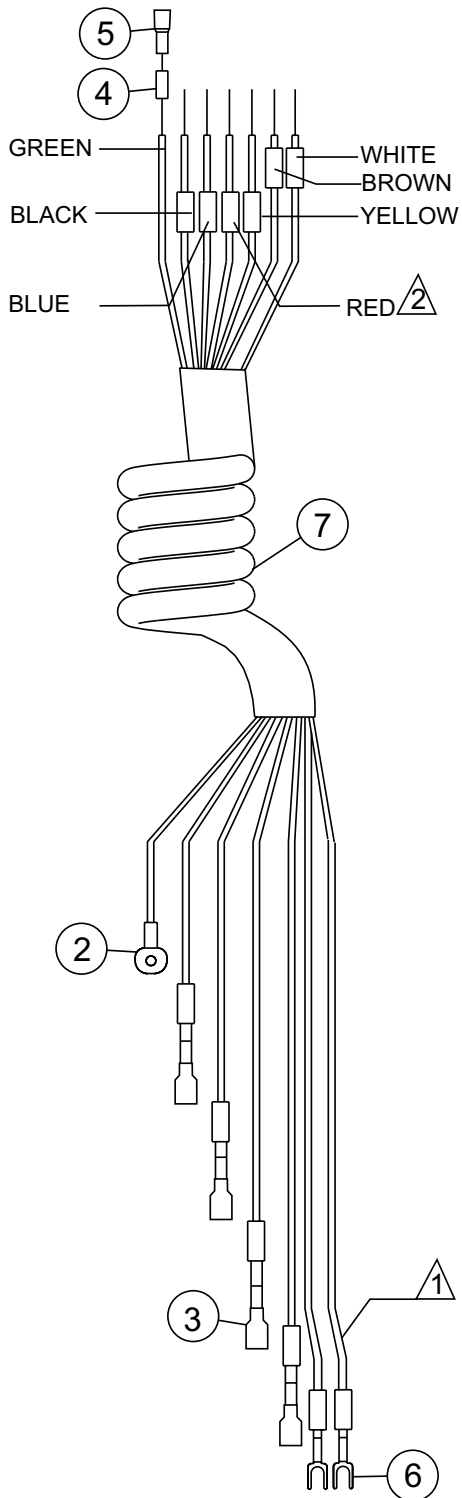

CONNECT TO BALLAST  
BOX OUTPUT

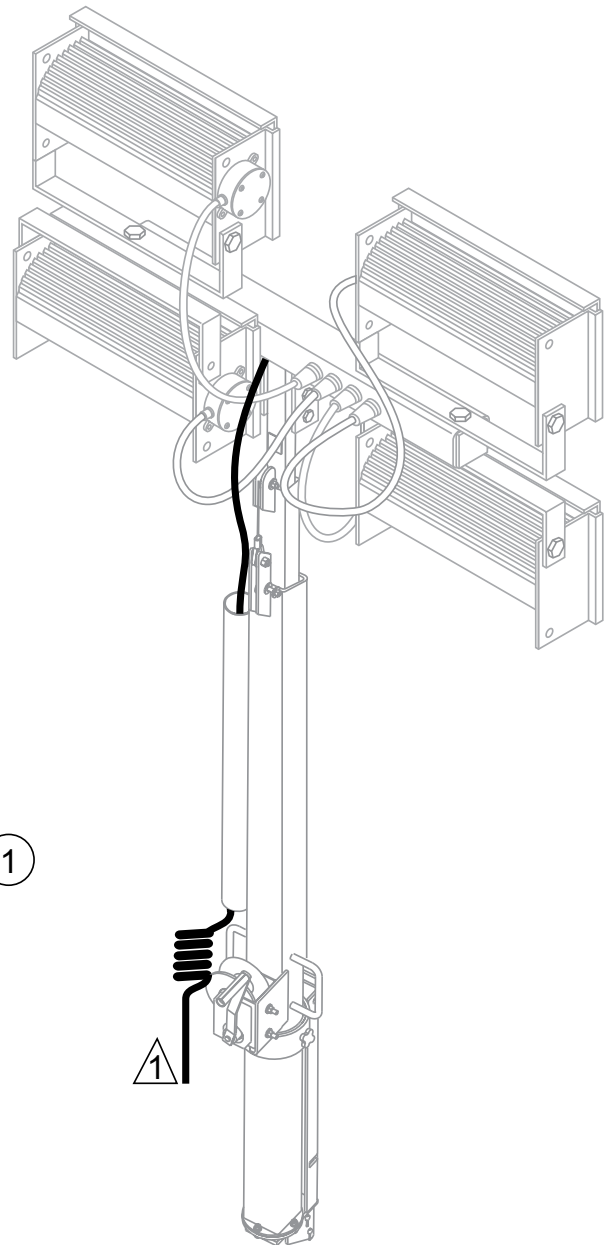

## NOTES:

- ① CONNECT THIS END OF COIL CORD ASSY. TO BALLAST BOX. REFERENCE ELECTRICAL SCHEMATIC DIAGRAM IN OPERATION MANUAL.
- ② CONNECT THIS END OF COIL CORD ASSY. TO T-BAR ASSY. REFERENCE ELECTRICAL SCHEMATIC DIAGRAM IN OPERATION MANUAL.

**COIL CORD ASSY.**

---

<u>NO.</u>	<u>PART NO.</u>	<u>PART NAME</u>	<u>QTY.</u>	<u>REMARKS</u>
1	29433	COIL CORD ASSY.....	1.....	INCLUDES ITEMS W/#
2#	3254	TERMINAL, RING 16-14 3/8	1	
3#	11947	TERMINAL, FEM 16-14 PUSH-ON, INS	4	
4#	19687	CRIMP, SLEEVE (30-410)	7	
5#	19688	INSULATOR, SPLICE CAP (2007)	7	
6#	19957	TERMINAL, SPADE 16-14, #10 INS	2	
7#	49030	COIL CORD , 600V, 7-WIRE	1	