

# OPERATION AND PARTS MANUAL



**SlabSaver SERIES**  
**MODEL FCG1-6HA**  
**CONCRETE SAW**  
**(HONDA GX200UQXC9 GASOLINE ENGINE)**

Revision #1 (03/19/10)

THIS MANUAL MUST ACCOMPANY THE EQUIPMENT AT ALL TIMES.

P/N: 38256

# TABLE OF CONTENTS

---

## **FCG16HA SlabSaver Concrete Saw**

## **Honda GX200QXC9 Engine**

Proposition 65 Warning .....	2
Silicosis/Respiratory Warnings .....	3
Table Of Contents .....	4
Specifications .....	5
Dimensions .....	6
Safety Message Alert Symbols .....	7-8
Rules For Safe Operation .....	9-11
General Information .....	12
Components .....	14-15
Basic Engine .....	16
Guards, Covers And V-Belts .....	17-18
Blades .....	19
Blade Placement .....	20-22
Inspection .....	23
Operation .....	24-27
Maintenance .....	28-29
Troubleshooting (Saw) .....	30
Troubleshooting (Engine) .....	31-32
Explanation Of Code In Remarks Column .....	34
Suggested Spare Parts .....	35

## **Component Drawings**

## SUGGESTED SPARE PARTS

---

### FCG16HA CONCRETE SAW 1 TO 3 UNITS WITH HONDA GX200QXC9 ENGINE

#### *1 to 3 Units*

Qty. ....	P/N .....	Description
2 .....	16052 .....	BELT
4 .....	25407 .....	WHEELS
2 .....	15028 .....	COLLARS, WHEEL
2 .....	15081 .....	GRIP, HANDLE
1 .....	25380 .....	BLADE, SHAFT/FLANGE
2 .....	15359 .....	BEARING, PILLOW BLOCK
1 .....	19710 .....	NUT, BLADE
3 .....	17210ZE1505 .....	AIR FILTER
3 .....	9807956846 .....	SPARK PLUG
1 .....	17620ZH7023 .....	FUEL CAP, TANK
1 .....	28462ZH8003 .....	STARTER ROPE

# DECAL LOCATOR

## DECAL LOCATOR

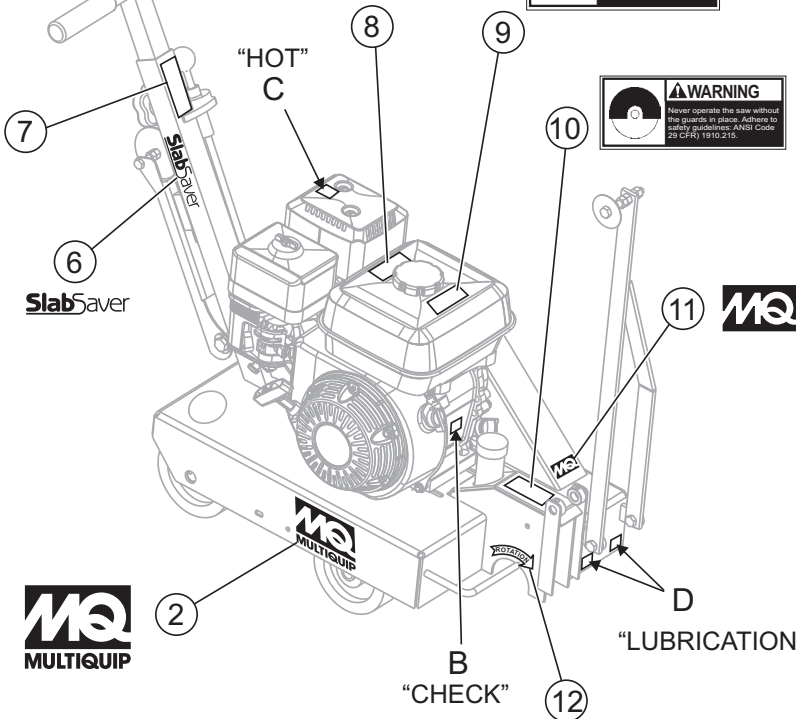
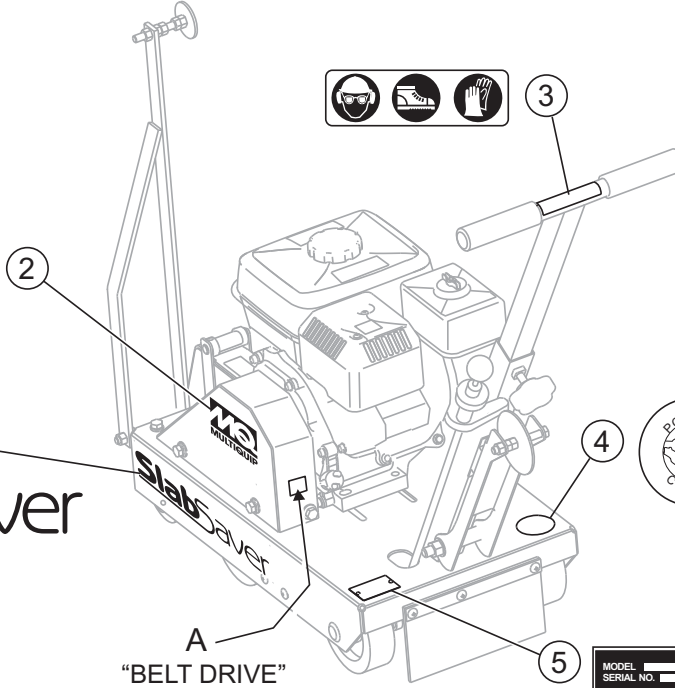

A →		
	BELT DRIVE	CLOCKWISE
	GEAR DRIVE	GEAR DRIVE
B →		
	CHECK	CHECK
C →		
	HOT	COUNTER CLOCKWISE
	LIFTING POINT	LIFTING POINT
D →		
	LUBRICATION	LUBRICATION
	LUBRICATION	LUBRICATION



## DECAL LOCATOR

---

### DECAL LOCATOR

<u>NO.</u>	<u>PART NO.</u>	<u>PART NAME</u>	<u>QTY.</u>	<u>REMARKS</u>
1	38231	DECAL, SLAB SAVER LARGE	1	
2	38213	DECAL, MQ LOGO 3.0 X 3-3/4	2	
3	36099	DECAL, SAFETY CLOTHING ISO BLUE .....	1 .....	SAFETY ITEM
4	13118	DECAL, POWDER COATED	1	
5		SERIAL NUMBER PLATE .....	1 .....	CONTACT PARTS DEPT.
6	38230	DECAL, SLAB SAVER SMALL	1	
7	25427	DECAL, DEPTH INDICATOR	1	
8	20525	DECAL, CA PROP 65 .....	1 .....	SAFETY ITEM
9	15580	DECAL, WARN RESPIRATORY 1-1/2 X 3 .....	1 .....	SAFETY ITEM
10	15581	DECAL, WARN BLADE GUARD 1-1/2 X 3 .....	1 .....	SAFETY ITEM
11	38239	DECAL, MQ LOGO	1	
12	25491	DECAL, BLADE ROTATION CW .....	1 .....	SAFETY ITEM
13	11246	DECAL, INTL STDS ISO BLACK .....	1 .....	SAFETY ITEM
14	25867	DECAL, ROTATION IN DISPLACEMENT .....	1 .....	SAFETY ITEM
15	35137	DECAL, READ MANUAL .....	1 .....	SAFETY ITEM
16	38226	DECAL, CE BLACK	1	
17	35166	DECAL, DECAL, GUARANTEED SOUND POWER 112 db	1	

# GUARDS ASSY.

GUARDS ASSY.

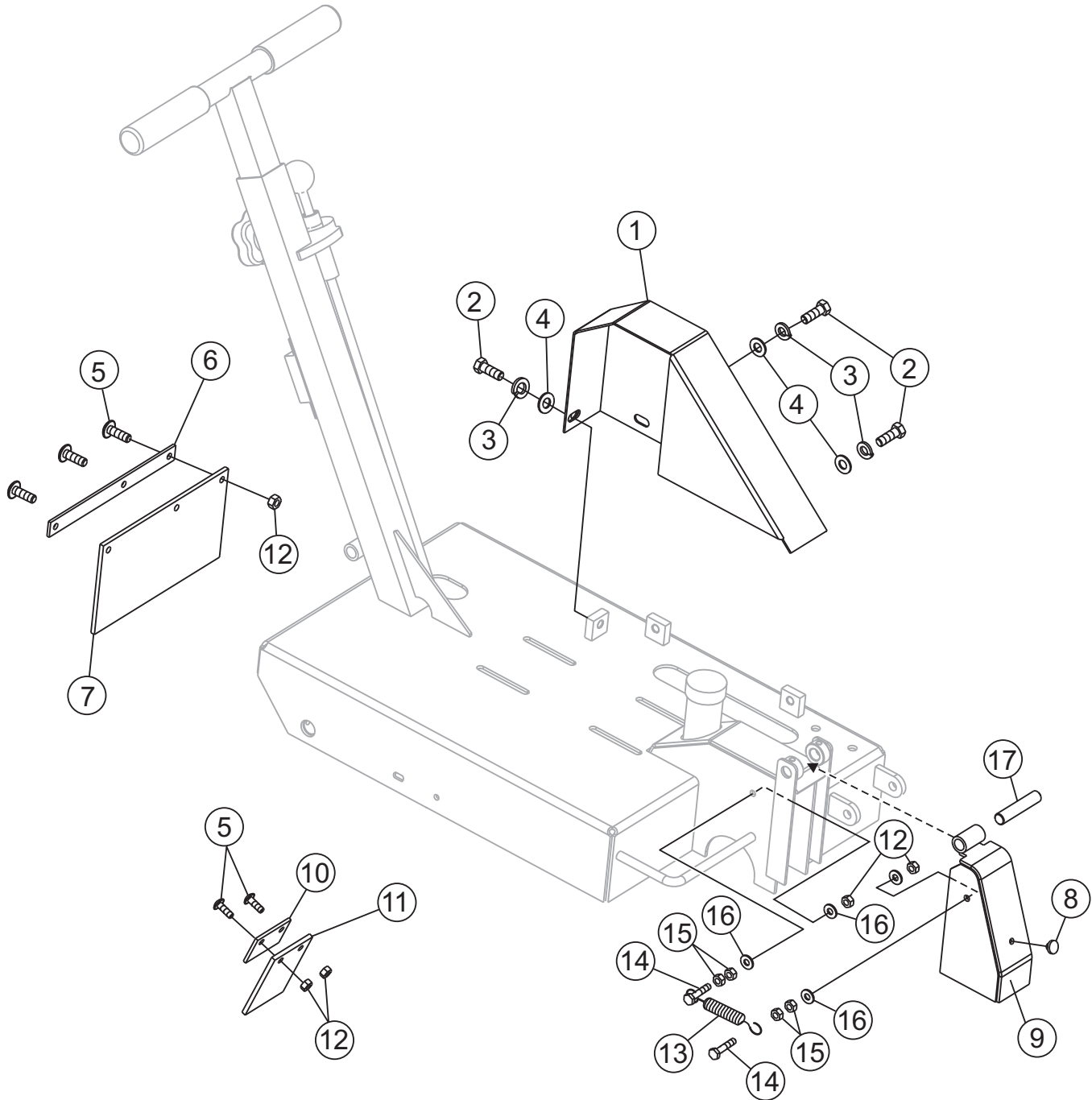

## GUARDS ASSY.

<b>NO.</b>	<b>PART NO.</b>	<b>PART NAME</b>	<b>QTY.</b>	<b>REMARKS</b>
1	25387	GUARD, BELT .....	1	SAFETY ITEM
2	4196	SCREW, HHC 3/8 - 16 X 0.75	3	
3	0166 A	WASHER, LOCK 3/8 MED	3	
4	10136	WASHER, FLAT 3/8 SAE	3	
5	12287	SCREW, THP 1/4 - 20 X 3/4 SS	3	
6	25430	SHEET, REAR WATER SHIELD .....	1	SAFETY ITEM
7	25431	FLAP, REAR WATER SHIELD .....	1	SAFETY ITEM
8	15161	STOP, RUBBER BUMPER	1	
9	25397	GUARD, BLADE 10" DOOR .....	1	SAFETY ITEM
10	25428	SHEET, FLAP MOUNT .....	1	SAFETY ITEM
11	25429	FLAP, FRONT WATER SHIELD .....	1	SAFETY ITEM
12	10024	NUT, NYLOC 1/4 - 20	7	
13	15509	SPRING, CENTURY .....	1	SAFETY ITEM
14	0424	SCREW, HHC 1/4 - 20 X 1-1/4	2	
15	0949	NUT, HEX FINISH 1/4 - 20	4	
16	0948	WASHER, FLAT 1/4 SA3	8	
17	25401	PIN, HINGE 0.5 X 2.5	1	

# GUIDES ASSY.

## GUIDES ASSY.

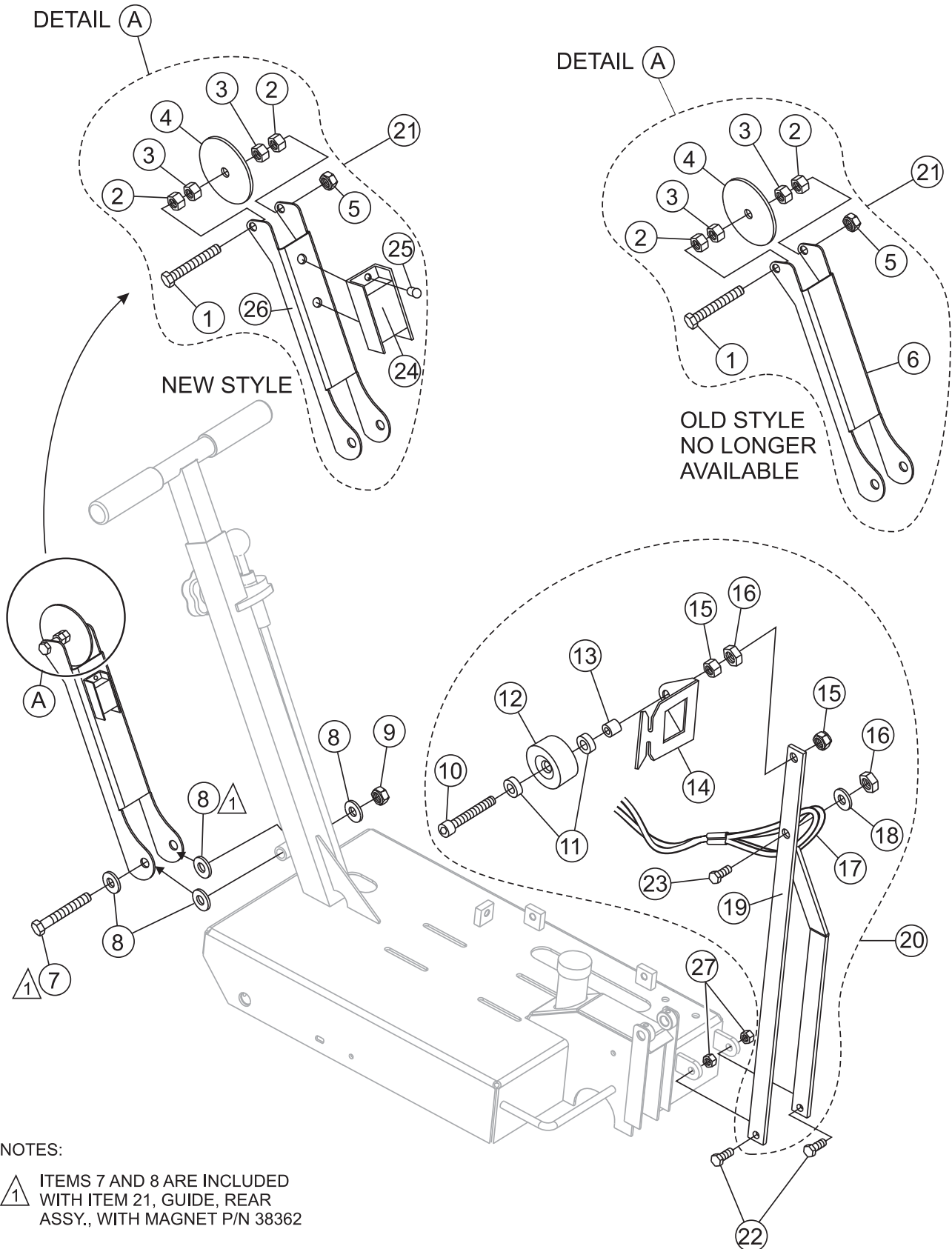



## GUIDES ASSY.

### GUIDES ASSY.

<u>NO.</u>	<u>PART NO.</u>	<u>PART NAME</u>	<u>QTY.</u>	<u>REMARKS</u>
1#	20473	SCREW, HHC 3/8 - 16 X 3 FULL THRD	1	
2#	1456	NUT, HEX FINISH 3/8 - 16	4	
3#	1007	NUT, HEX JAM 3/8 - 16	4	
4#	25449	WHEEL, GUIDE 3.5 OD X .41 ID FCG	1	
5#	10133	NUT, NYLOC 3/8 - 16	1	
6	25392	SHEET, REAR GUIDE .....	1	NO LONGER AVAILABLE
7#	3215	SCREW, HHC 1/2 - 13 X 3-1/2	1	
8#	36128	WASHER, NYLON 1/2" ID	4	
9#	10176	NUT, NYLOC 1/2 - 13	1	
10*	35476	SCREW, SHC 5/16-18 X 3.5 FULL THRD	1	
11*	21369	BEARING, SEALED 5/16 ID X 7/8 OD	2	
12*	21189	WHEEL, 2.13 OD X 1.25 W POLYURETHANE	1	
13*	21185	SPACER, 1/2 X 5/16 X 3/8 P33-3	1	
14*	21368	PLATE, POINTER (GUIDE) FCG	1	
15*	5283	NUT, NYLOC 5/16-18	2	
16*	0161 D	NUT, HEX FINISH 5/16-18	2	
17*	35096	SASH ASSY., WIRE ROPE	1	
18*	19470	WASHER, FLAT 5/16 USS	1	
19*	35093	ARM, FRONT POINTER (GUIDE) W/A, FCG	1	
20	35097	POINTER (GUIDE) ASSY., WHEEL STYLE .....	1	INCLUDES ITEMS W/*
21	25416	GUIDE, REAR ASSY. ....	1	NO LONGER AVAILABLE
21	38362	GUIDE, REAR ASSY. ....	1	FEB, 2010
		.....		INCLUDES ITEMS W/#
22*	0205	SCREW, HHC 3/8 - 16 X 1.0	2	
23*	0202	SCREW, HHC 5/16 - 18 X 1 ZINC	1	
24#	38365	MAGNET, FCG REAR ARM	1	
25#	19847	RIVET, POP, ALUM, 3/16X1/8-1/4 GRIP	2	
26#	38366	ARM, REAR POINTER WHEEL	1	
27	10133	NUT, NYLOC 3/8 - 16	2	

# UNDERCARRIAGE ASSY.

UNDER CARRIAGE ASSY.

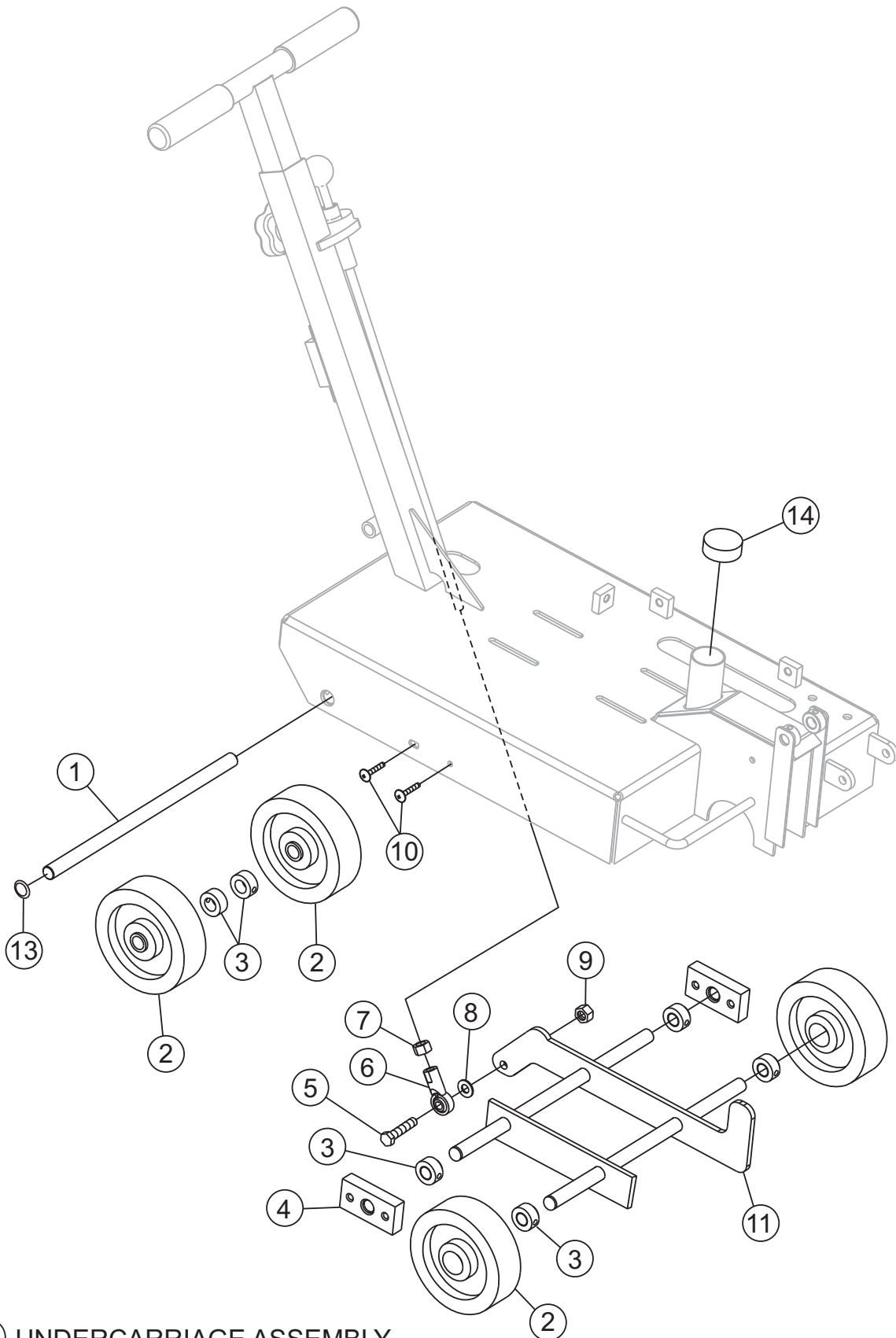

⑫ UNDERCARRIAGE ASSEMBLY

## UNDERCARRIAGE ASSY.

---

### UNDER CARRIAGE ASSY.

<u>NO.</u>	<u>PART NO.</u>	<u>PART NAME</u>	<u>QTY.</u>	<u>REMARKS</u>
1	25368	BAR, PIVOT SHAFT	1	
2	25407	WHEEL, 5 X .625 X 1.5 BALL BRG	4	
3	15028	COLLAR, SET 5/8 DIA	4	
4	25379	BEARING, 5/8 FLANGE UHMW	2	
5	9154	SCREW, HHC 3/8 - 16 X 1-3/4	1	
6	2064	ROD END, 3/8 -24 FEM RH	1	
7	2199	NUT, HEX JAM 3/8 -24	1	
8	10136	WASHER, FLAT 3/8 SAE	AR	
9	10133	NUT, JAM 3/8 - 16	1	
10	29448	SCREW, THP 1/4 - 20 X X 1.25	4	
11	25365	RAISE-LOWER W/A	1	
12	15414	UNDERCARRIAGE ASSEMBLY	1	
13	25489	PLUG, 3/4 BLK PLASTIC	2	
14	25409	CAP, 1-1/2 ID BLACK	1	

# HANDLE & DEPTH ADJUSTER ASSY.

HANDLE & DEPTH ADJUSTER ASSY.

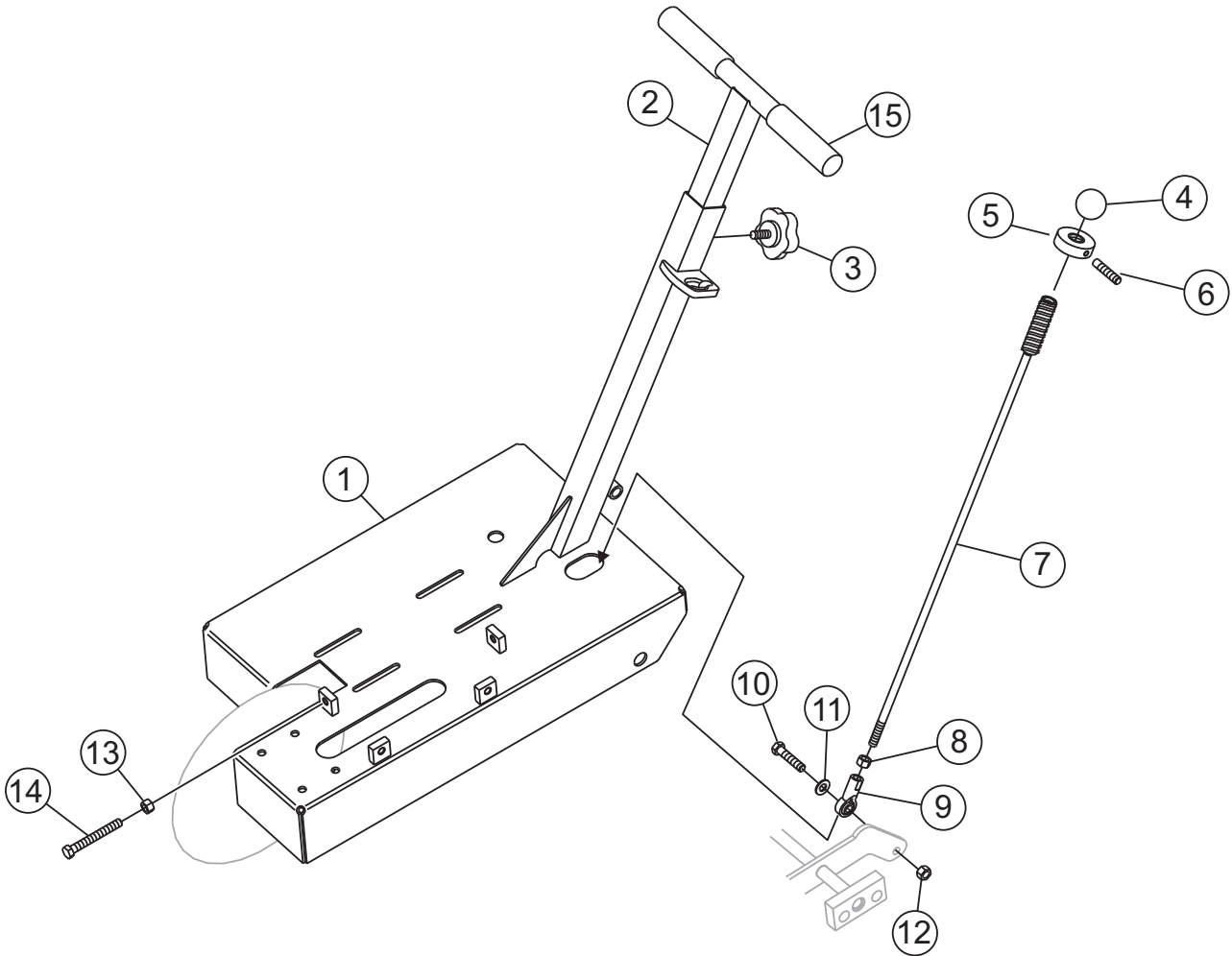

## HANDLE & DEPTH ADJUSTER ASSY.

---

### HANDLE & DEPTH ADJUSTER ASSY.

<u>NO.</u>	<u>PART NO.</u>	<u>PART NAME</u>	<u>QTY.</u>	<u>REMARKS</u>
1	25357	FRAME	1	
2	25419	HANDLEBAR	1	
3	15503	KNOB, COMFORT GRIP	1	
4	4403	KNOB, SHIFT	1	
5	25448	DEPTH ADJUST DISK	1	
6	25480	SCREW PLUNGER, 1/4 - 20 X 17/32	1	
7	25446	ROD, DEPTH STOP	1	
8	2199	NUT, HEX JAM 3/8 -24	1	
9	2064	ROD END, 3/8 -24 FEM RH	1	
10	9154	SCREW, HHC 3/8 - 16 X 1-3/4	1	
11	10136	WASHER, FLAT 3/8 SAE	AR	
12	10133	NUT, NYLOC 3/8 - 16	1	
13	1007	NUT, HEX JAM 3/8 - 16	1	
14	9154	SCREW, HHC 3/8 - 16 X 3	1	
15	15081	GRIP, HANDLE	2	

# ENGINE & BLADE DRIVE ASSY.

ENGINE & BLADE DRIVE ASSY.

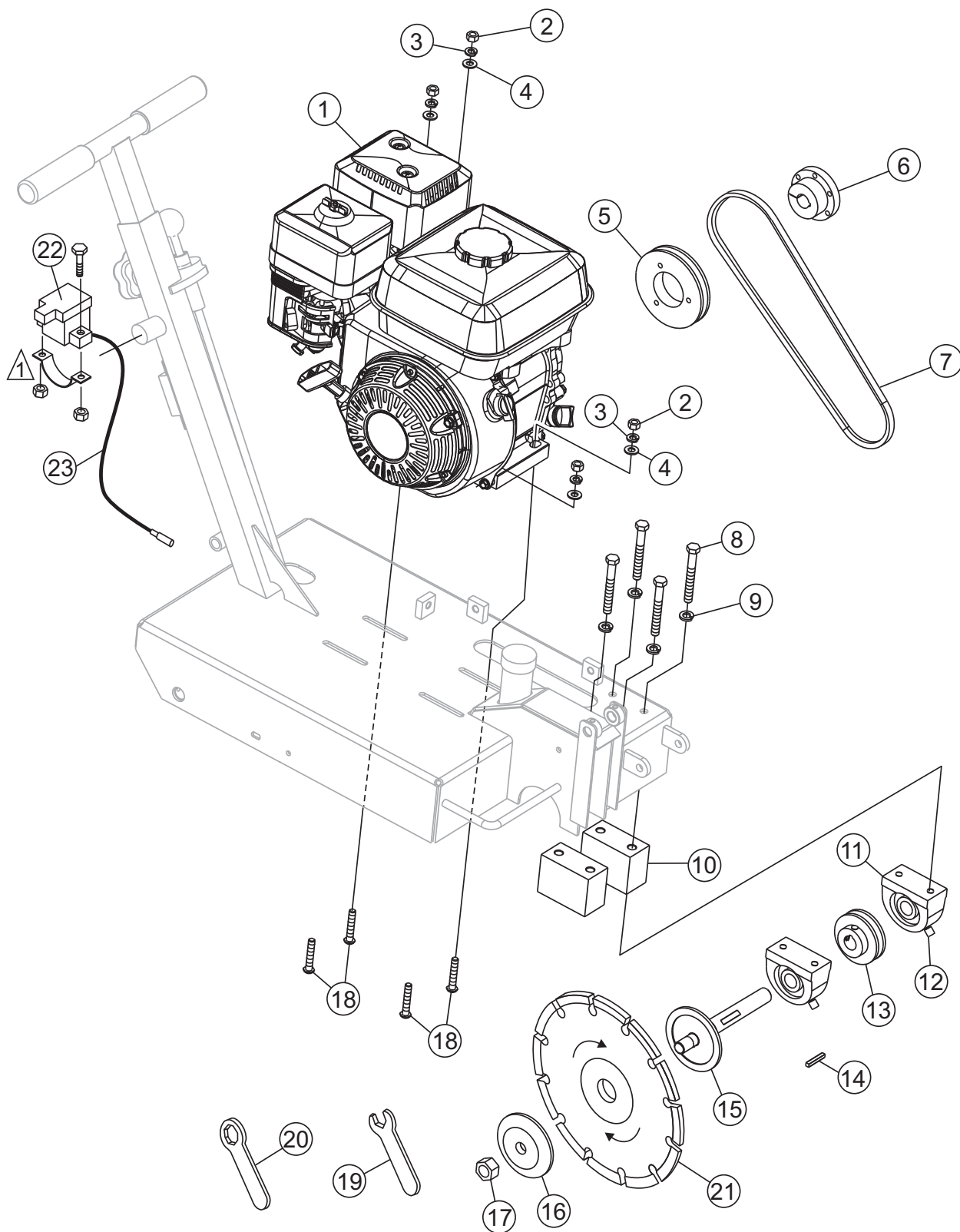

NOTES:

⚠ SWITCH MOUNTING HARDWARE IS INCLUDED WITH SWITCH.

## ENGINE & BLADE DRIVE ASSY.

---

### ENGINE & BLADE DRIVE ASSY.

<u>NO.</u>	<u>PART NO.</u>	<u>PART NAME</u>	<u>QTY.</u>	<u>REMARKS</u>
1	25378	ENGINE, 6.5 HP HONDA GX200UQXC9 (SHOWN)	1	
2	0161 D	NUT, HEX FINISH 5/16 - 18	4	
3	0161 C	WASHER, LOCK 5/16 MED	4	
4	0300 B	WASHER, FLAT 5/16	4	
5	25356	PULLEY, 13V412SH	1	
6	25417	BUSHING, PULLEY SH - 3/4	1	
7	16052	BELT, 3VX335 GATES/OPTIPLEX	1	
8	0169	SCREW, HHC 3/8 - 16 X 3.0	4	
9	0166 A	WASHER, LOCK 3/8 MED	4	
10	25377	SPACER, BEARING	2	
11	15359	BEARING, PIL BLOCK, BRN. VTBS-212	2	
12	1162 A	CAP, GREASE ZERK #2	2	
13	25442	PULLEY, 1F3V26 3/4" BORE	1	
14	0627	KEY, SQ 3/16 X 1-1/4	1	
15	25380	BLADE, SHAFT/FLANGE ASM	1	
16	25418	FLANGE, 3.38 O.D.	1	
17	19710	NUT, HEX 5/8 - 11 LH THRD	1	
18	25410	BOLT, CARRAIGE 5/16 - 18 X 1.75	3	
19	25487	WRENCH, SERVICE 15/16 OPEN END	1	
20	25488	WRENCH, 5/8 COMBO	1	
21	9SWG	BLADE, DIAMOND BACK.....	1	ORDER FROM UNIT SALES DEPT.
22	35127	SWITCH, ENGINE SHUT-OFF MAGURA .....	1	SAFETY ITEM
23	35155	WIRE ASSY., ENGINE SHUT-OFF SWITCH .....	1	SAFETY ITEM

# HONDA GX200QXC9 — AIR CLEANER (CYCLONE) ASSY.

AIR CLEANER (CYCLONE) ASSY.

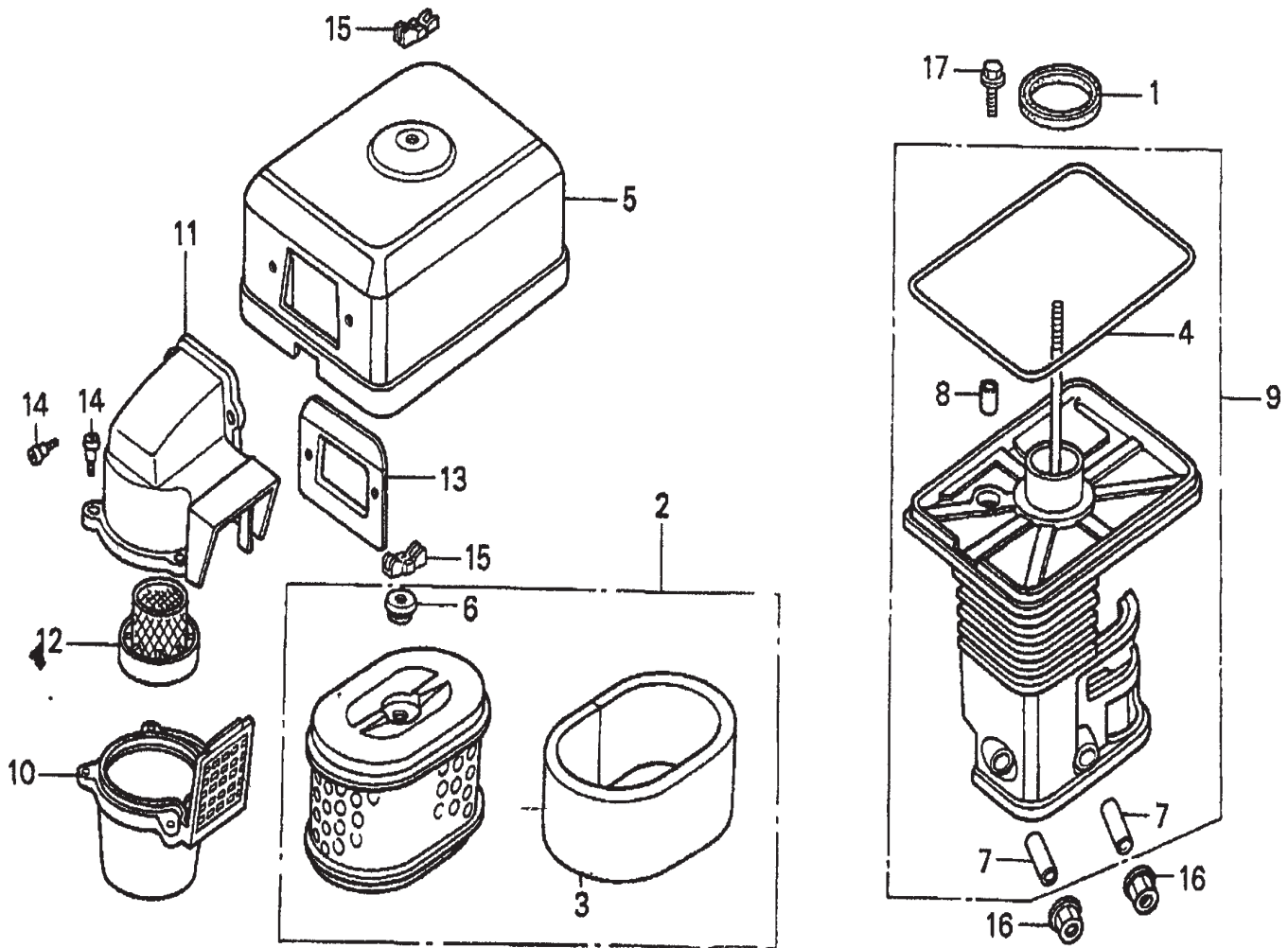



# HONDA GX200QXC9 — AIR CLEANER (CYCLONE) ASSY.

---

## AIR CLEANER (CYCLONE) ASSY.

<u>NO.</u>	<u>PART NO.</u>	<u>PART NAME</u>	<u>QTY.</u>	<u>REMARKS</u>
1	16271ZE1000	GASKET, ELBOW	1	
2	17210ZE1505	ELEMENT, AIR CLEANER (DUAL) .....	1 .....	INCLUDES ITEMS W/*
3*	17218ZE1821	FILTER (OUTER)	1	
4*	17219733010	GASKET, AIR CLEANER COVER	1	
5	17230ZE1841	COVER, AIR CLEANER (DUAL)	1	
6*	17232891000	GROMMET, AIR CLEANER	1	
7+	17238ZE7010	COLLAR, AIR CLEANER	2	
8+	17239733000	COLLAR B, AIR CLEANER	1	
9	17410ZE1840	ELBOW, AIR CLEANER .....	1 .....	INCLUDES ITEMS W/+
10	17470ZE1841	CASE, PRE AIR CLEANER	1	
11	17475ZE1841	CAP, PREAIR CLEANER	1	
12	17476ZE1841	GUIDE, PRE AIR CLEANER	1	
13	17478ZE1841	PLATE, PRE AIR CLEANER	1	
14	90300GB0900	BOLT, MUDGUARD	5	
15	90325044000	WINGNUT, TOOL BOX SETTING	2	
16	9405006000	NUT, FLANGE 6MM	2	
17	957010602000	BOLT, FLANGE 6 X 20	1	

# HONDA GX200QXC9 — CAMSHAFT ASSY.

CAMSHAFT ASSY.

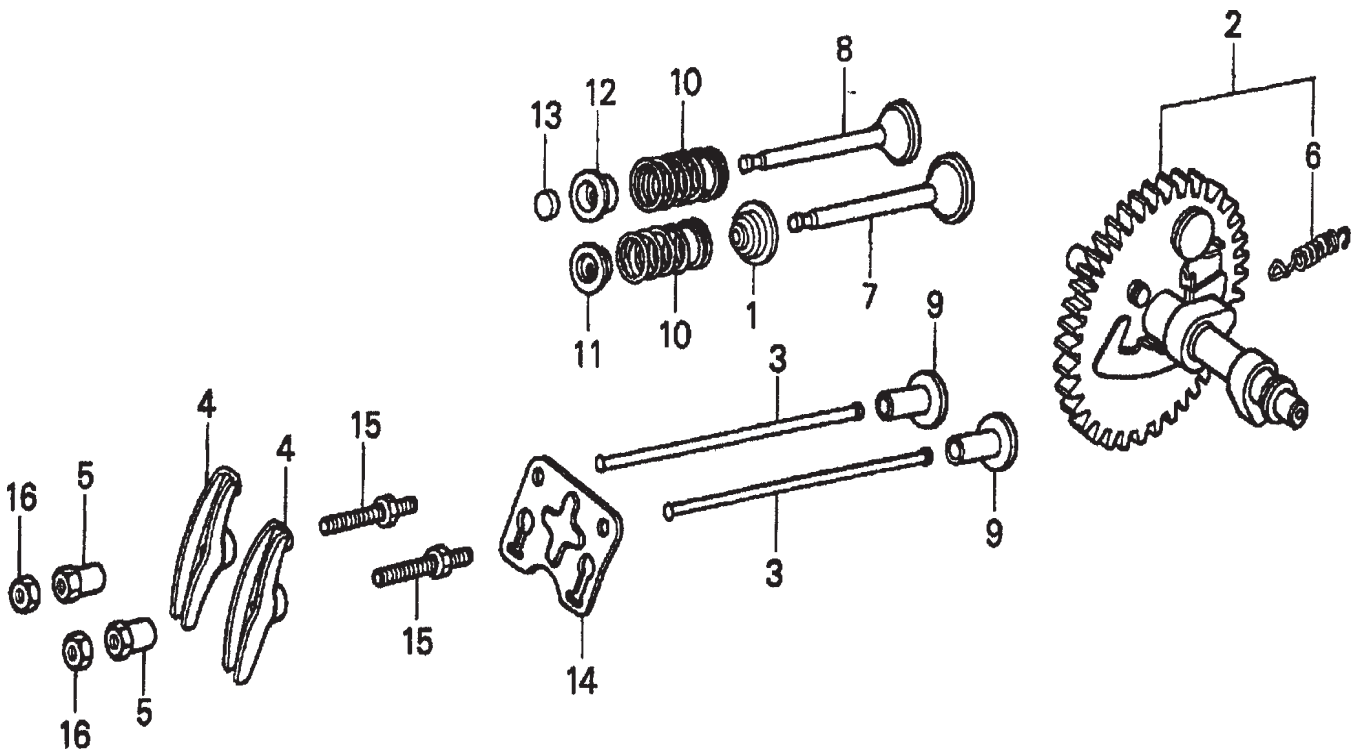

## HONDA GX200QXC9 — CAMSHAFT ASSY.

---

### CAMSHAFT ASSY.

<u>NO.</u>	<u>PART NO.</u>	<u>PART NAME</u>	<u>QTY.</u>	<u>REMARKS</u>
1	12209ZH8003	SEAL, VALVE STEM	1	
2	14100ZL0000	CAMSHAFT ASSEMBLY .....	1 .....	INCLUDES ITEM W/*
3	14410ZE1010	ROD, PUSH	2	
4	14431ZE1000	ARM, VALVE ROCKER	2	
5	14451ZE1013	PIVOT, ROCKER ARM	2	
6*	14568ZE1000	SPRING, WEIGHT RETURN	1	
7	14711ZF1000	VALVE, INTAKE	1	
8	14721ZF1000	VALVE, EXHAUST	1	
9	14731ZL0000	LIFTER, VALVE	2	
10	14751ZF1000	SPRING, VALVE	2	
11	14771ZE1000	RETAINER, INTAKE VALVE SPRING	1	
12	14773ZE1000	RETAINER, EXHAUST VALVE SPRING	1	
13	14781ZE1000	ROTATOR, VALVE	1	
14	14791ZE1010	PLATE, PUSH ROD GUIDE	1	
15	90012ZE0010	BOLT, PIVOT 8MM	2	
16	90206ZE1000	NUT, PIVOT ADJ.	2	

# HONDA GX200QXC9 — CARBURETOR ASSY.

CARBURETOR ASSY.

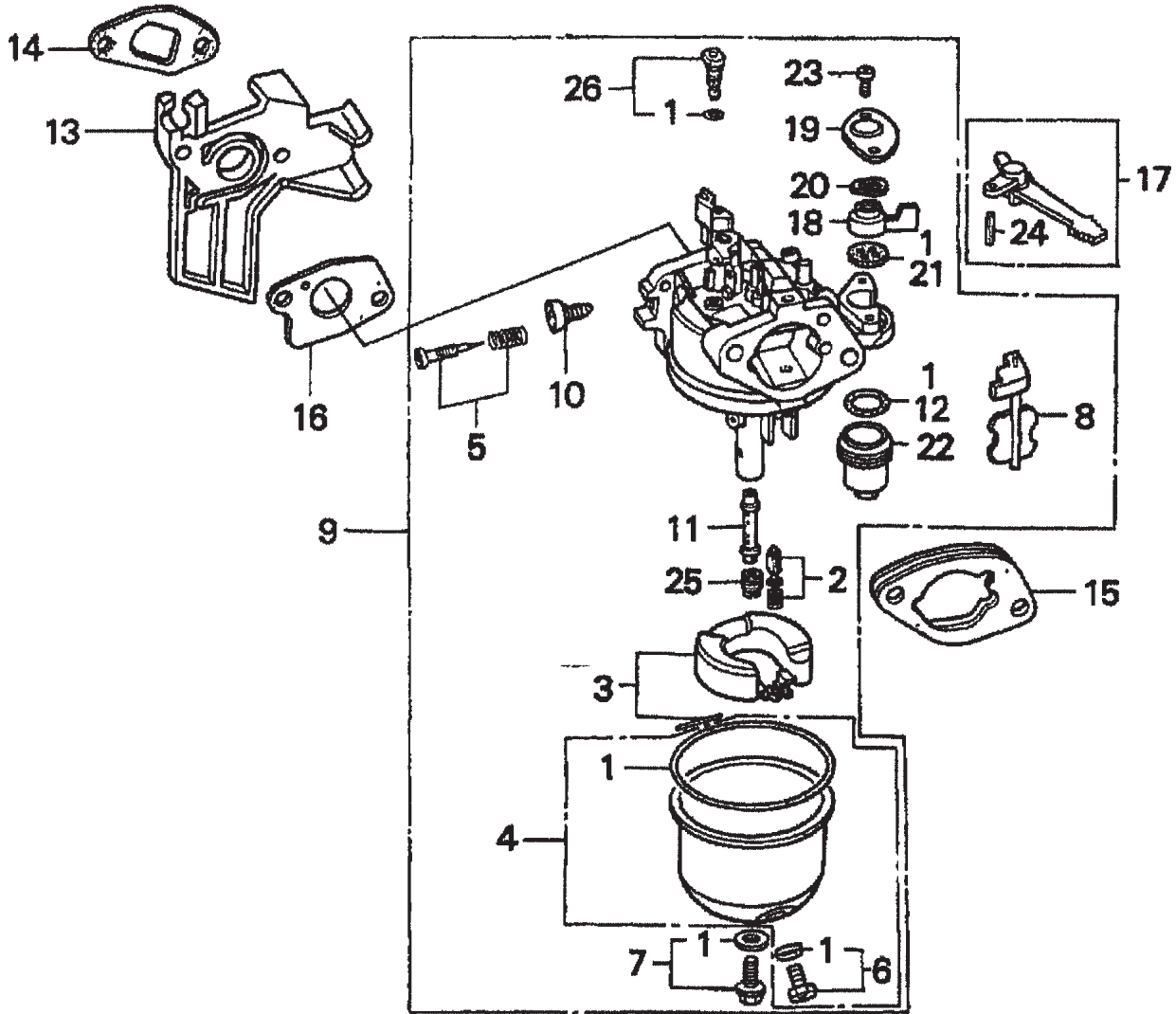

## HONDA GX200QXC9 — CARBURETOR ASSY.

### CARBURETOR ASSY.

<u>NO.</u>	<u>PART NO.</u>	<u>PART NAME</u>	<u>QTY.</u>	<u>REMARKS</u>
1*	16010ZE1812	GASKET SET	1	
2*	16011ZE0005	VALVE SET, FLOAT	1	
3*	16013ZE0005	FLOAT SET	1	
4*	16015ZE0831	CHAMBER SET, FLOAT	1	
5*	16016ZH7W01	SCREW SET	1	
6*	16024ZE1811	SCREW SET, DRAIN	1	
7*	16028ZE0005	SCREW SET B	1	
8*	16044ZE0005	CHOKE SET	1	
9	16100ZL0V21	CARBURETOR ASSEMBLY (BE64F B) .....	1	INCLUDES ITEMS W/*
10*	16124ZE0005	SCREW, THROTTLE STOP	1	
11*	16166ZL0V20	NOZZLE, MAIN	1	
12*	16173001004	GASKET, FUEL STRAINER CUP	1	
13	16211ZL0000	INSULATOR, CARBURETOR	1	
14	16212ZH8800	GASKET, INSULATOR	1	
15	16220ZE1020	SPACER, CARBURETOR	1	
16	16221ZH8801	GASKET, CARBURETOR	1	
17	16610ZE1000	LEVER, CHOKE (STANDARD) .....	1	INCLUDES ITEM W/ %
18*	16953ZE1812	LEVER, VALVE	1	
19*	16954ZE1812	PLATE, LEVER SETTING	1	
20*	16956ZE1811	SPRING, VALVE LEVER	1	
21*	16957ZE1812	GASKET, VALVE	1	
22*	16967ZE0811	CUP, FUEL STRAINER	1	
23*	93500030060H	SCREW, PAN 3 X 6	2	
24 %	9430520122	PIN, SPRING 2 X12	1	
25	99101ZH80700	JET, MAIN #70 (OPTIONAL)	1	
25*	99101ZH80720	JET, MAIN #72	1	
25*	99101ZH80750	JET, MAIN #75	1	
26*	99204ZA00450	JET SET, PILOT #45	1	

# HONDA GX200QXC9 — CONTROL ASSY.

CONTROL ASSY.

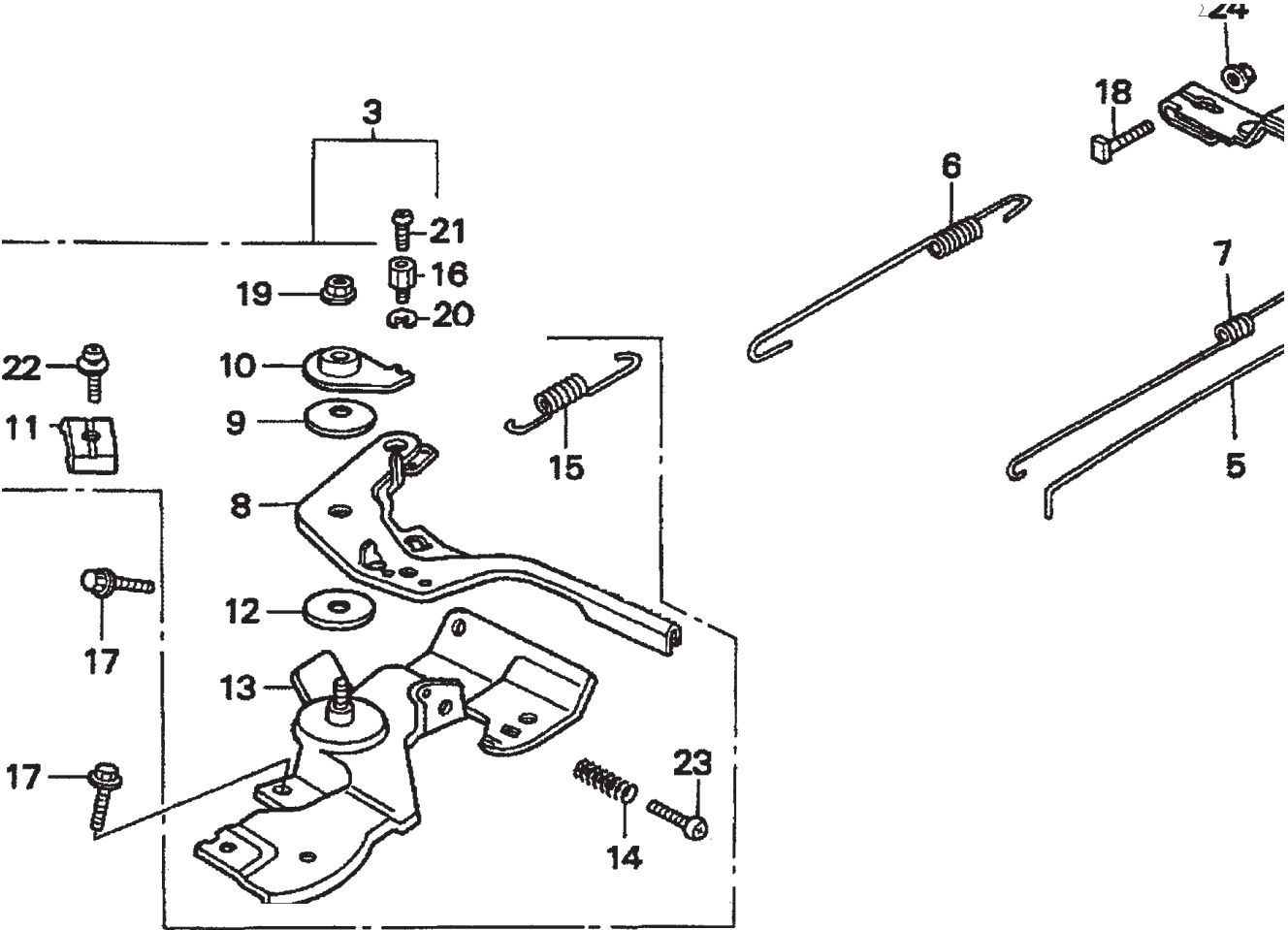

# HONDA GX200QXC9 — CONTROL ASSY.

## CONTROL ASSY.

<u>NO.</u>	<u>PART NO.</u>	<u>PART NAME</u>	<u>QTY.</u>	<u>REMARKS</u>
3	16500ZH8853	CONTROL ASSEMBLY (CYCLONE) .....	1 .....	INCLUDES ITEMS W/*
4	16551ZL0000	ARM, GOVERNOR	1	
5	16555ZE1000	ROD, GOVERNOR	1	
6	16561ZL0000	SPRING, GOVERNOR	1	
7	16562ZE1020	SPRING, THROTTLE RETURN	1	
8*	16571ZH8020	LEVER, CONTROL	1	
9*	16574ZE1000	SPRING, LEVER	1	
10*	16575ZH8000	WASHER, CONTROL LEVER	1	
11*	16576891000	HOLDER, CABLE	1	
12*	16578ZE1000	SPACER, CONTROL LEVER	1	
13*	16580ZH8853	BASE, CONTROL (CYCLONE)	1	
14*	16584883300	SPRING, CONTROL ADJUSTING	1	
15*	16592ZE1810	SPRING, CABLE RETURN	1	
16*	16594883010	HOLDER, WIRE	1	
17	90013883000	BOLT, FLANGE 6 X12 (CT200)	2	
18	90015ZE5010	BOLT, GOVERNOR ARM	1	
19*	90114SA0000	NUT, SELF- LOCK 6MM	1	
20*	90605230000	CIRCLIP 5MM	1	
21*	93500040060H	SCREW, PAN 4 X6	1	
22*	93500050160A	SCREW, PAN 5 X16	1	
23*	93500050250H	SCREW, PAN 5 X25	1	
24	9405006000	NUT, FLANGE 6MM	1	

# HONDA GX200QXC9 — CRANKCASE COVER ASSY.

CRANKCASE COVER ASSY.

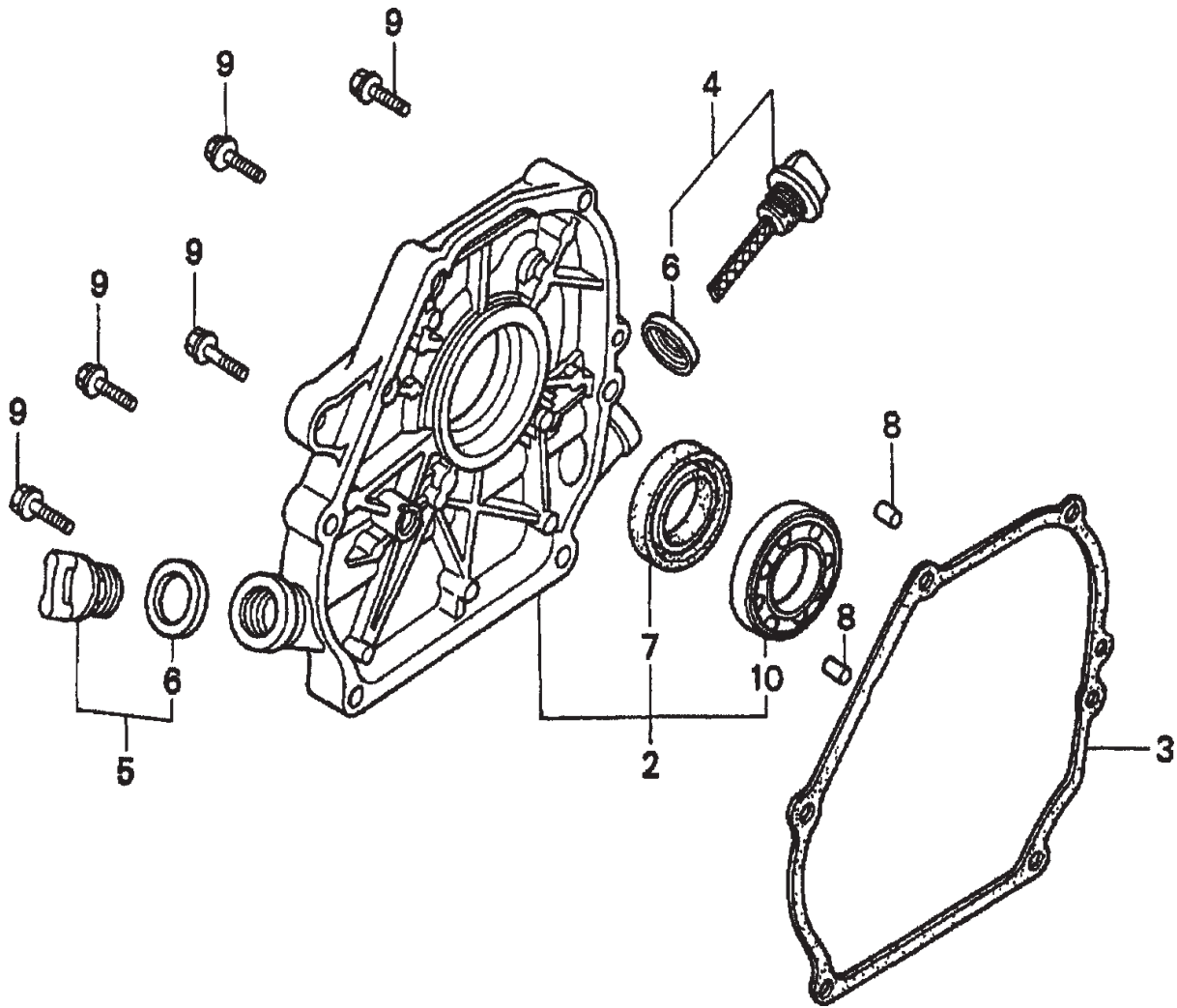



## HONDA GX200QXC9 — CRANKCASE COVER ASSY.

---

### CRANKCASE COVER ASSY.

<u>NO.</u>	<u>PART NO.</u>	<u>PART NAME</u>	<u>QTY.</u>	<u>REMARKS</u>
2	11300ZE1641	COVER ASSEMBLY, CRANKCASE (U- TYPE) .....	1 .....	INCLUDES ITEMS W/*
3	11381ZH8801	GASKET, CASE COVER (NON- ASBESTOS) .....	1 .....	USE UP TO ENGINE SN 1002566
3	11381ZL0000	GASKET, CASE COVER .....	1 .....	USE FROM ENGINE SN 1002567
4	15600ZE1003	CAP ASSEMBLY, OIL FILLER .....	1 .....	INCLUDES ITEM W/+
5	15600ZG4003	CAP ASSEMBLY, OIL FILLER .....	1 .....	INCLUDES ITEM W/+
6+	15625ZE1003	GASKET, OIL FILLER CAP	2	
7*	91202883005	OIL SEAL 25 X41 X6	1	
8	9430108140	PIN A, DOWEL 8 X14	2	
9	957010803200	BOLT, FLANGE 8 X32	6	
10*	961006205000	BEARING, RADIAL BALL 6205	1	

# HONDA GX200QXC9 — CRANKSHAFT ASSY.

CRANKSHAFT ASSY.

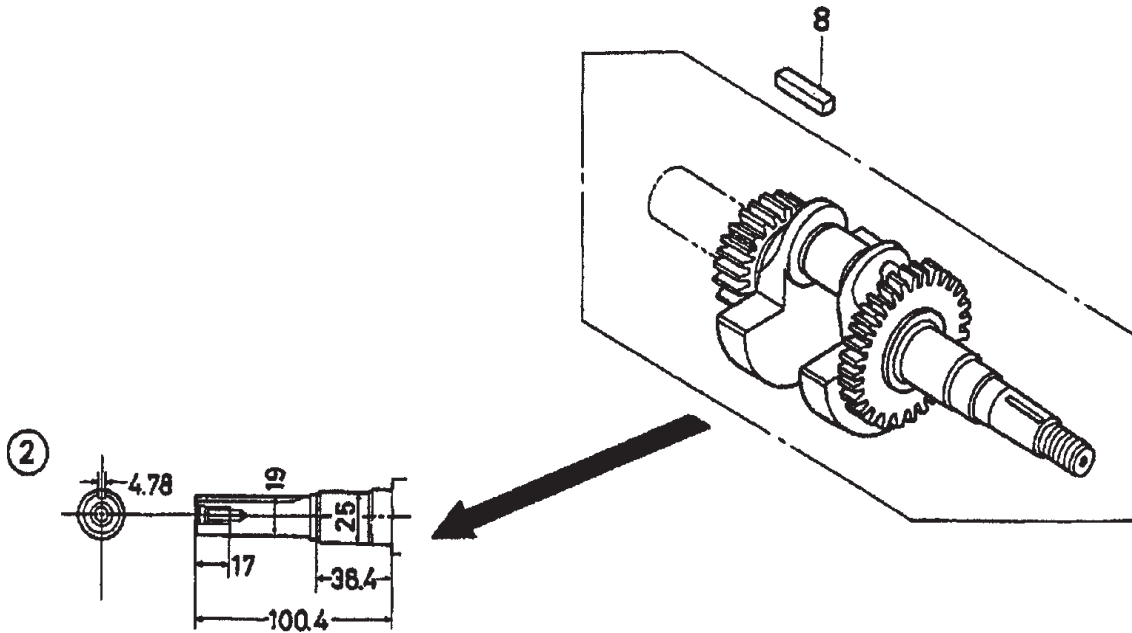

# HONDA GX200QXC9 — CRANKSHAFT ASSY.

---

CRANKSHAFT ASSY.

<u>NO.</u>	<u>PART NO.</u>	<u>PART NAME</u>	<u>QTY.</u>	<u>REMARKS</u>
2	13310ZL0600	CRANKSHAFT (Q-TYPE)	1	
8	90745ZE1600	KEY 4.78 X4.78 X38	1	

# HONDA GX200QXC9 — CYLINDER BARREL ASSY.

CYLINDER BARREL ASSY.

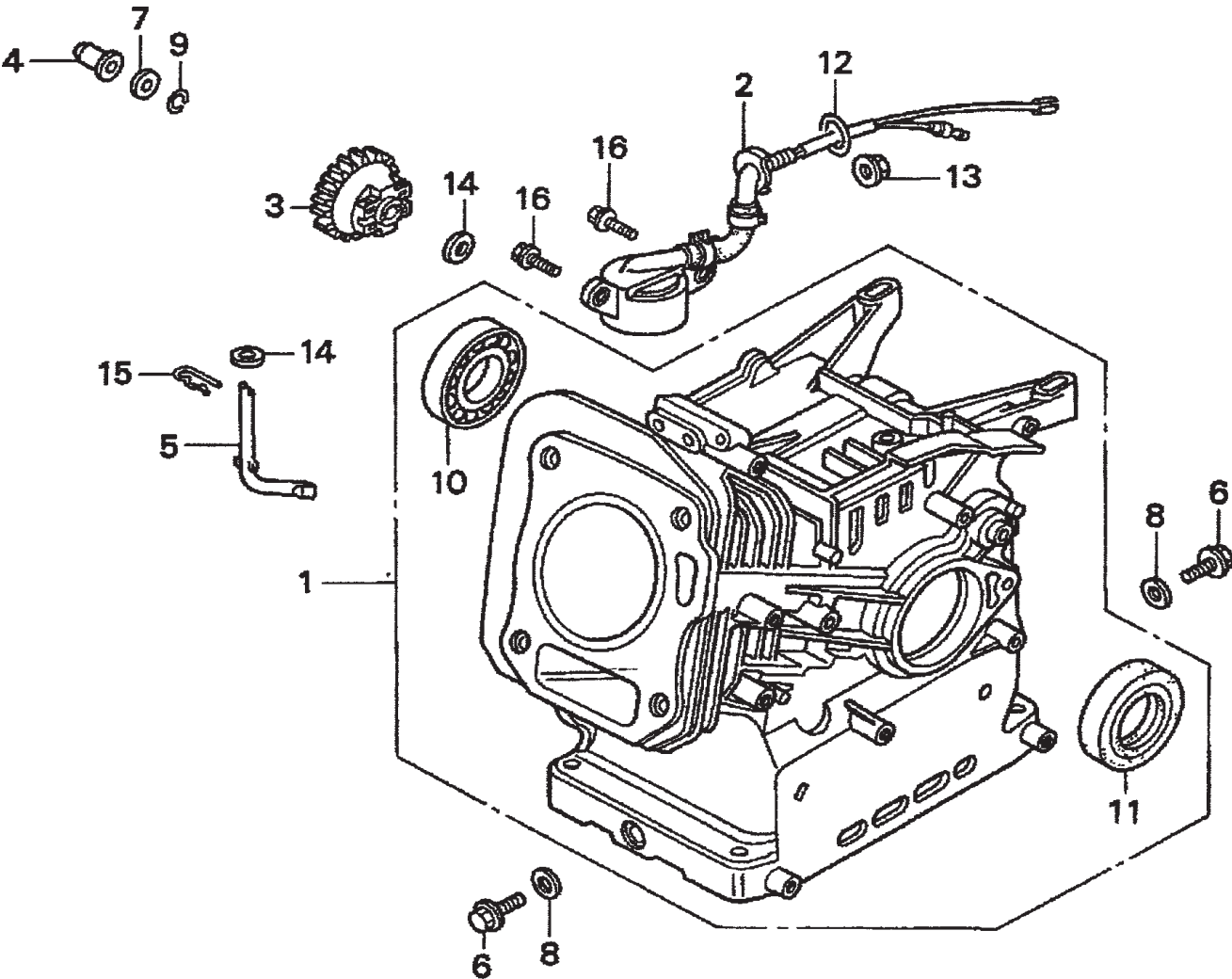

# HONDA GX200QXC9 — CYLINDER BARREL ASSY.

---

## CYLINDER BARREL ASSY.

<u>NO.</u>	<u>PART NO.</u>	<u>PART NAME</u>	<u>QTY.</u>	<u>REMARKS</u>
1	12000ZL0810	CYLINDER ASSEMBLY (OIL ALERT) .....	1 .....	INCLUDES ITEMS W/*
2	15510ZE1033	SWITCH ASSEMBLY, OIL LEVEL	1	
3	16506ZL0000	GOVERNOR ASSEMBLY	1	
4	16531ZE1000	SLIDER, GOVERNOR	1	
5	16541ZE1000	SHAFT, GOVERNOR ARM	1	
6	90131ZE1000	BOLT, DRAIN PLUG	2	
7	90451ZE1000	WASHER, THRUST 6MM	1	
8	90601ZE1000	WASHER, DRAIN PLUG 10.2MM	2	
9	90602ZE1000	CLIP, GOVERNOR HOLDER	1	
10*	91001ZF1003	BEARING, RADIAL BALL 6205	1	
11*	91202883005	OIL SEAL 25 X41 X6	1	
12	91353671003	O- RING 13.5 X1.5 (ARAI)	1	
13	9405010000	NUT, FLANGE 10MM	1	
14	9410106800	WASHER, PLAIN 6MM	2	
15	9425108000	PIN, LOCK 8MM	1	
16	957010601200	BOLT, FLANGE 6 X12	2	

# HONDA GX200QXC9 — CYLINDER HEAD ASSY.

CYLINDER HEAD ASSY.

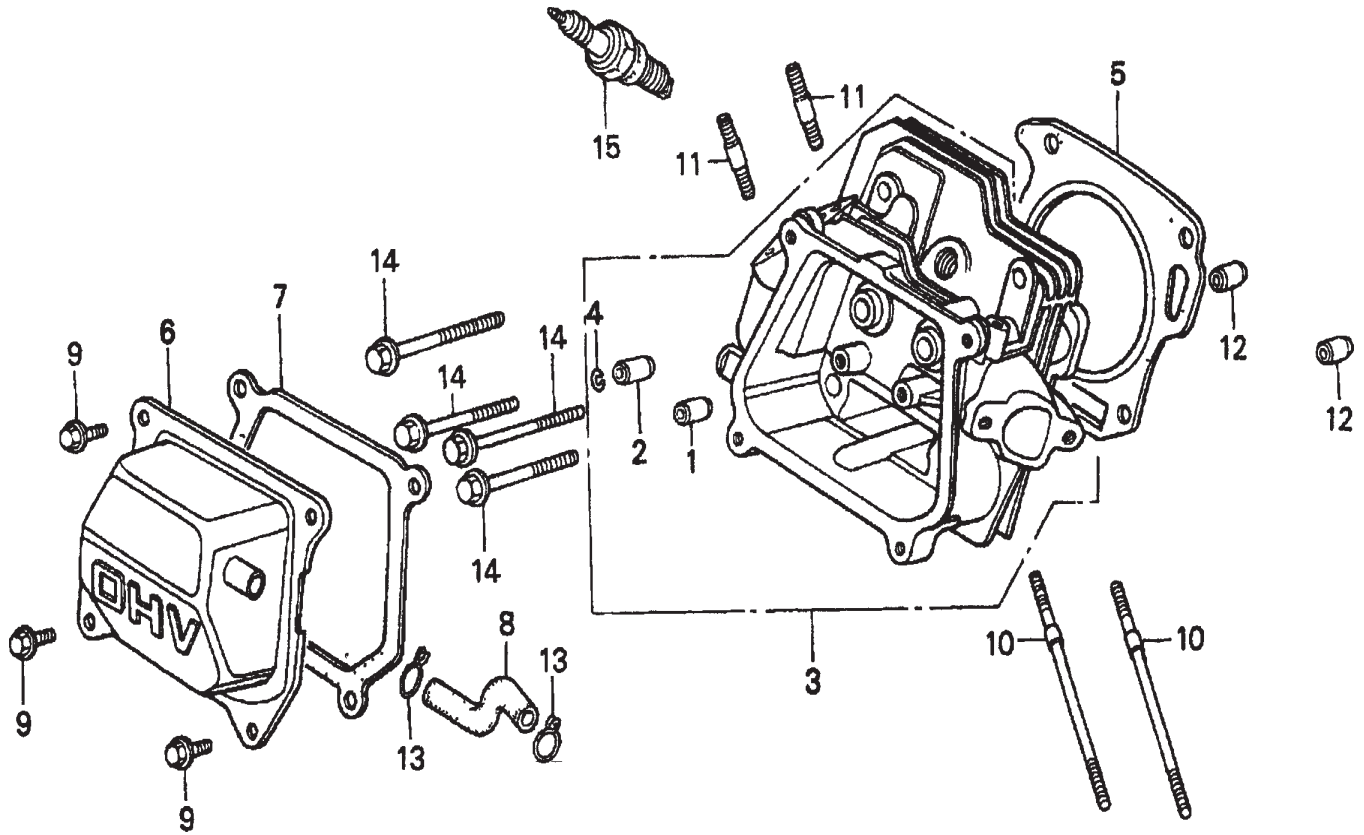

## HONDA GX200QXC9 — CYLINDER HEAD ASSY.

---

### CYLINDER HEAD ASSY.

<u>NO.</u>	<u>PART NO.</u>	<u>PART NAME</u>	<u>QTY.</u>	<u>REMARKS</u>
1*	12204ZE1306	GUIDE, VALVE OS (OPTIONAL)	1	
2*	12205ZE1315	GUIDE, EXHAUST VALVE OS (OPTIONAL)	1	
3	12210ZL0000	CYLINDER HEAD .....	1 .....	INCLUDES ITEMS W/*
4*	12216ZE5300	CLIP, VALVE GUIDE	1	
5	12251ZL0003	GASKET, CYLINDER HEAD	1	
6	12310ZE1841	COVER, HEAD (BREATHER TUBE)	1	
7	12391ZE1000	GASKET, CYLINDER HEAD COVER	1	
8	15721ZE1840	TUBE, BREATHER	1	
9	90013883000	BOLT, FLANGE 6 X12 (CT200)	4	
10	90043ZE1020	BOLT, STUD 6 X109	2	
11	90047ZE1000	BOLT, STUD 8 X32	2	
12	9430110160	PIN A DOWEL 10 X16	2	
13	9500280000	CLIP, TUBE C12	2	
14	957230806000	BOLT, FLANGE 8 X60	4	
15	9807956846	SPARK PLUG BPR6ES (NGK)	1	
15	9807956855	SPARK PLUG W20EPR- U (DENSO)	1	

# HONDA GX200QXC9 — FAN COVER ASSY.

FAN COVER ASSY.

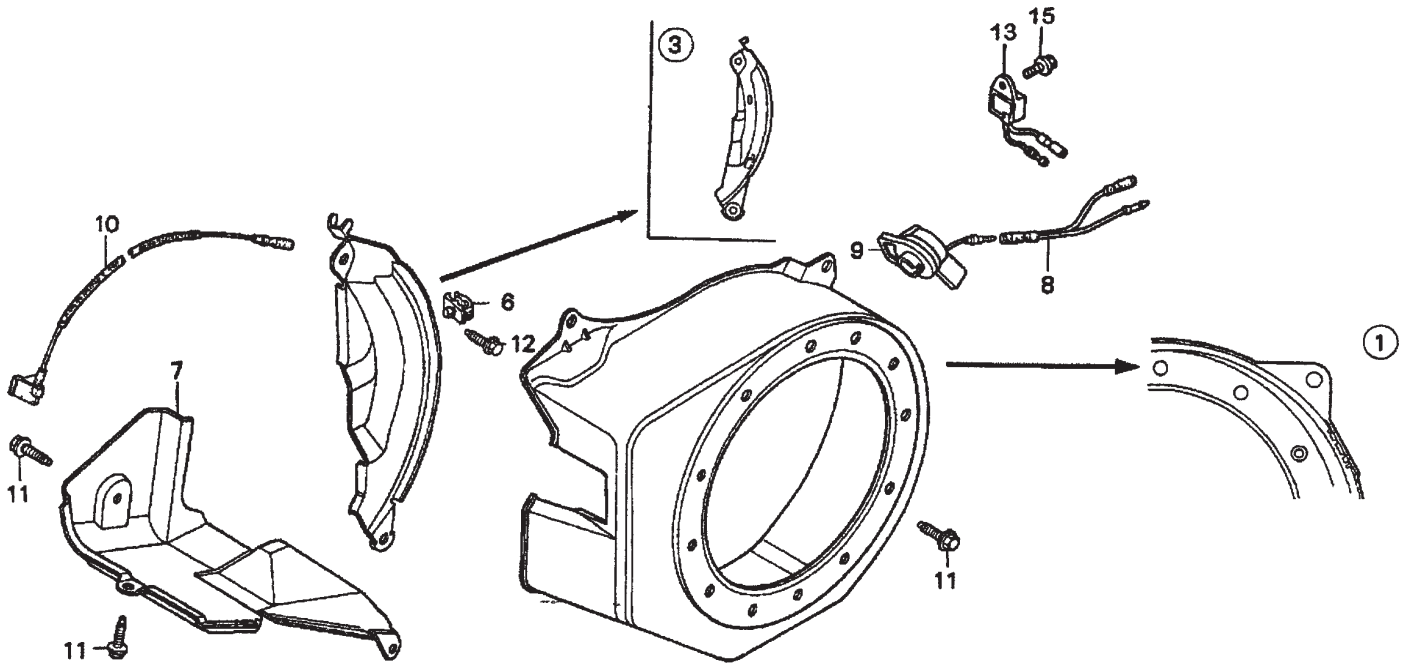



## HONDA GX200QXC9 — FAN COVER ASSY.

---

### FAN COVER ASSY.

<u>NO.</u>	<u>PART NO.</u>	<u>PART NAME</u>	<u>QTY.</u>	<u>REMARKS</u>
1	19610ZL0000ZB	COVER, FAN *R8* BRIGHT RED	1	
3	19611ZH8810	PLATE, SIDE (OIL ALERT)	1	
6	19613ZE1010	CLAMP, CORD	1	
7	19630ZH8000	SHROUD	1	
8	32197ZH8003	SUB- HARNESS	1	
9	36100ZH7003	SWITCH ASSEMBLY, ENGINE STOP	1	
10	36101ZE1010	WIRE, STOP SWITCH 370MM	1	
11	90013883000	BOLT, FLANGE 6 X12 (CT200)	6	
12	90022888010	BOLT, FLANGE 6 X20 (CT200)	1	
13	34150ZH7003	ALERT UNIT, OIL	1	
15	957010600800	BOLT, FLANGE 6 X8	1	

# HONDA GX200QXC9 — FLYWHEEL ASSY.

FLYWHEEL ASSY.

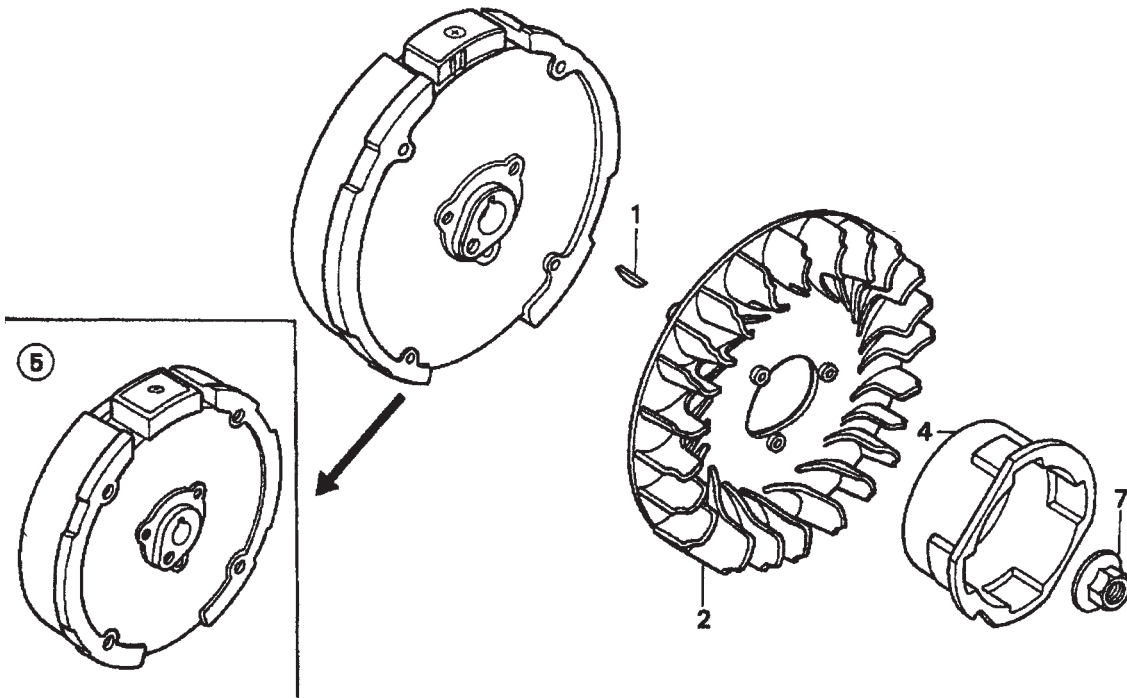

## HONDA GX200QXC9 — FLYWHEEL ASSY.

---

FLYWHEEL ASSY.

<u>NO.</u>	<u>PART NO.</u>	<u>PART NAME</u>	<u>QTY.</u>	<u>REMARKS</u>
1	13331357000	KEY, SPECIAL WOODRUFF 25 X18	1	
2	19511ZE1000	FAN, COOLING	1	
4	28451ZL0000	PULLEY, STARTER	1	
5	31100ZE7010	FLYWHEEL, STANDARD	1	
7	90201878003	NUT, SPECIAL 14MM	1	

# HONDA GX200QXC9 — FUEL TANK ASSY.

FUEL TANK ASSY.

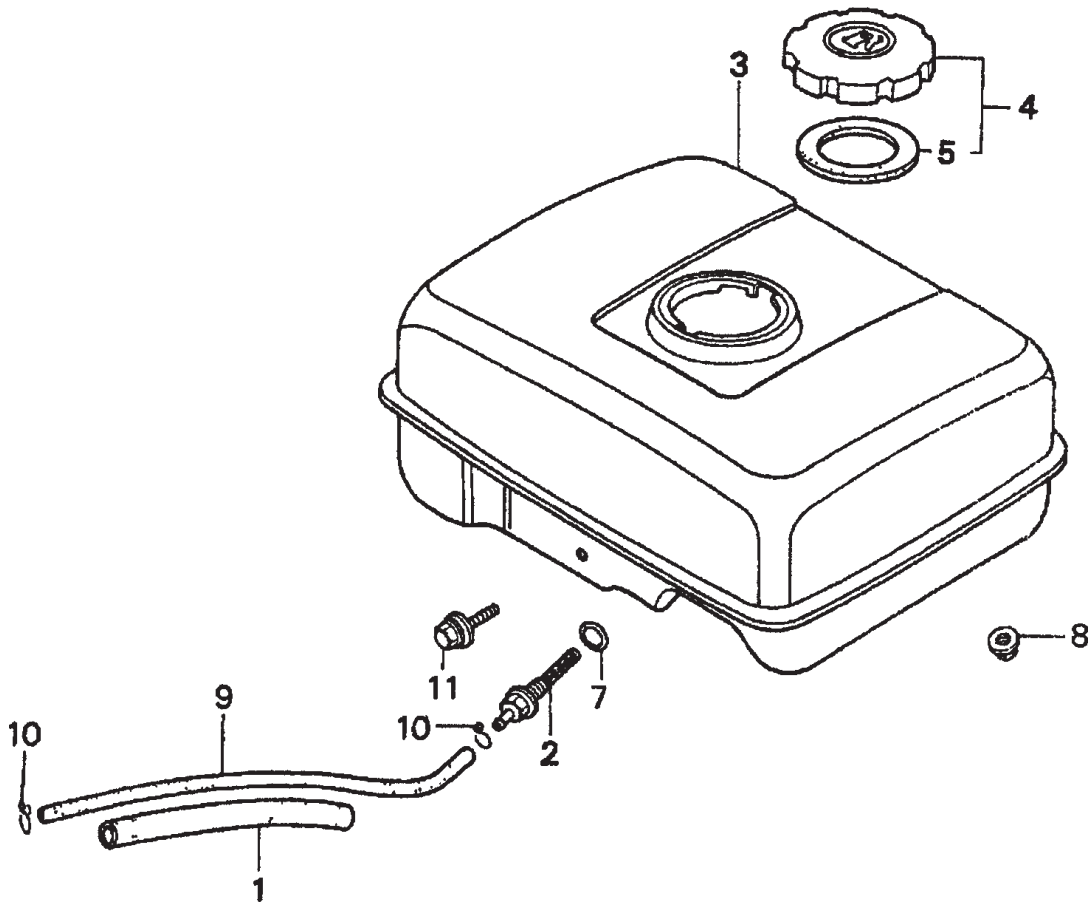

## HONDA GX200QXC9 — FUEL TANK ASSY.

---

### FUEL TANK ASSY.

<u>NO.</u>	<u>PART NO.</u>	<u>PART NAME</u>	<u>QTY.</u>	<u>REMARKS</u>
1	16854ZH8000	RUBBER, SUPPORTER 107MM	1	
2	16955ZE1000	JOINT, FUEL TANK	1	
3	17510ZE1020ZA	TANK, FUEL *NH31* MCKINLEY WHITE	1	
4	17620ZH7023	CAP, FUEL FILLER .....	1	INCLUDES ITEM W/*
5*	17631ZH7003	GASKET, FUEL FILLER CAP	1	
7	91353671003	O- RING 13.5 X1.5 (ARAI)	1	
8	9405006000	NUT, FLANGE 6MM	2	
9	950014500360M	BULK HOSE, FUEL (4.5 X3000) (4.5 X140)	1	
10	9500202080	CLIP, TUBE B8	2	
11	957010603000	BOLT, FLANGE 6 X30	1	

# HONDA GX200QXC9 — IGNITION COIL ASSY.

IGNITION COIL ASSY.

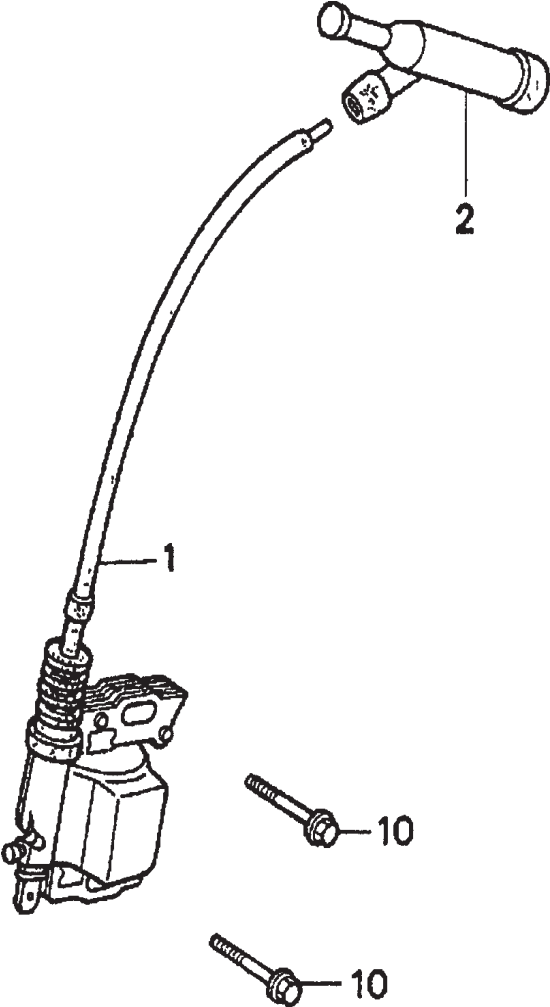

## HONDA GX200QXC9 — IGNITION COIL ASSY.

---

IGNITION COIL ASSY.

<u>NO.</u>	<u>PART NO.</u>	<u>PART NAME</u>	<u>QTY.</u>	<u>REMARKS</u>
1	30500ZE1033	COIL ASSEMBLY, IGNITION	1	
2	30700ZE1013	CAP ASSEMBLY, NOISE SUPPRESSOR	1	
10	90121952000	BOLT, FLANGE 6 X25	2	

# HONDA GX200QXC9 — MUFFLER ASSY.

MUFFLER ASSY.

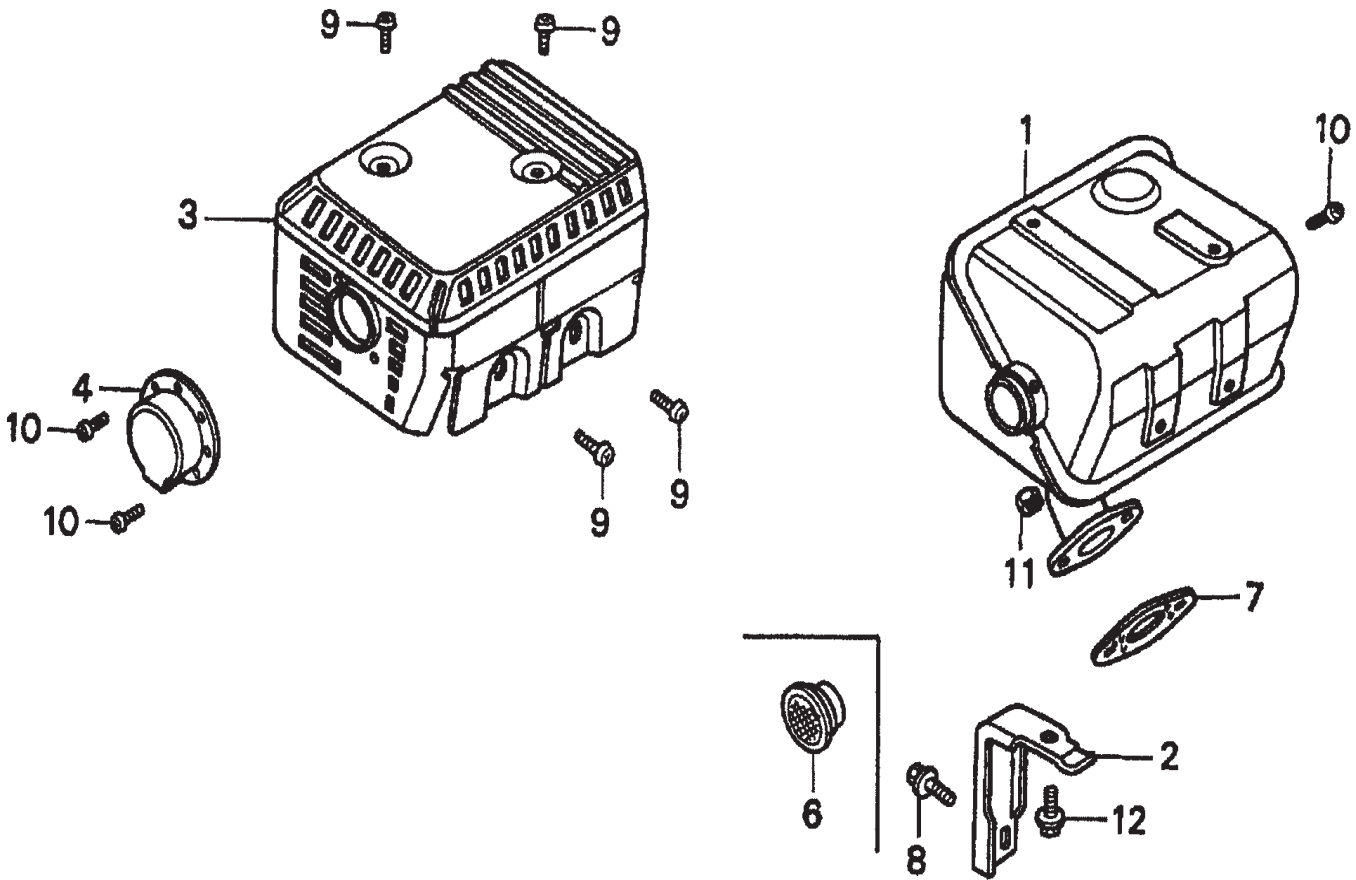



## HONDA GX200QXC9 — MUFFLER ASSY.

---

### MUFFLER ASSY.

<u>NO.</u>	<u>PART NO.</u>	<u>PART NAME</u>	<u>QTY.</u>	<u>REMARKS</u>
1	18310ZL0000	MUFFLER	1	
2	18315ZE1000	STAY, MUFFLER	1	
3	18320ZF1H51	PROTECTOR, MUFFLER	1	
4	18331883810	CAP, MUFFLER	1	
6	18361ZL0000	NETTING, WIRE FLANGE	1	
7	18381ZH8800	GASKET, MUFFLER	1	
8	90016ZE1000	BOLT, FLANGE 6 X13	1	
9	90050ZE1000	SCREW, TAPPING 5 X8	4	
10	90055ZE1000	SCREW, TAPPING 4 X6	3	
11	94001080000S	NUT, HEX. 8MM	2	
12	957010601200	BOLT, FLANGE 6 X12	1	

# HONDA GX200QXC9 — PISTON ASSY.

PISTON ASSY.

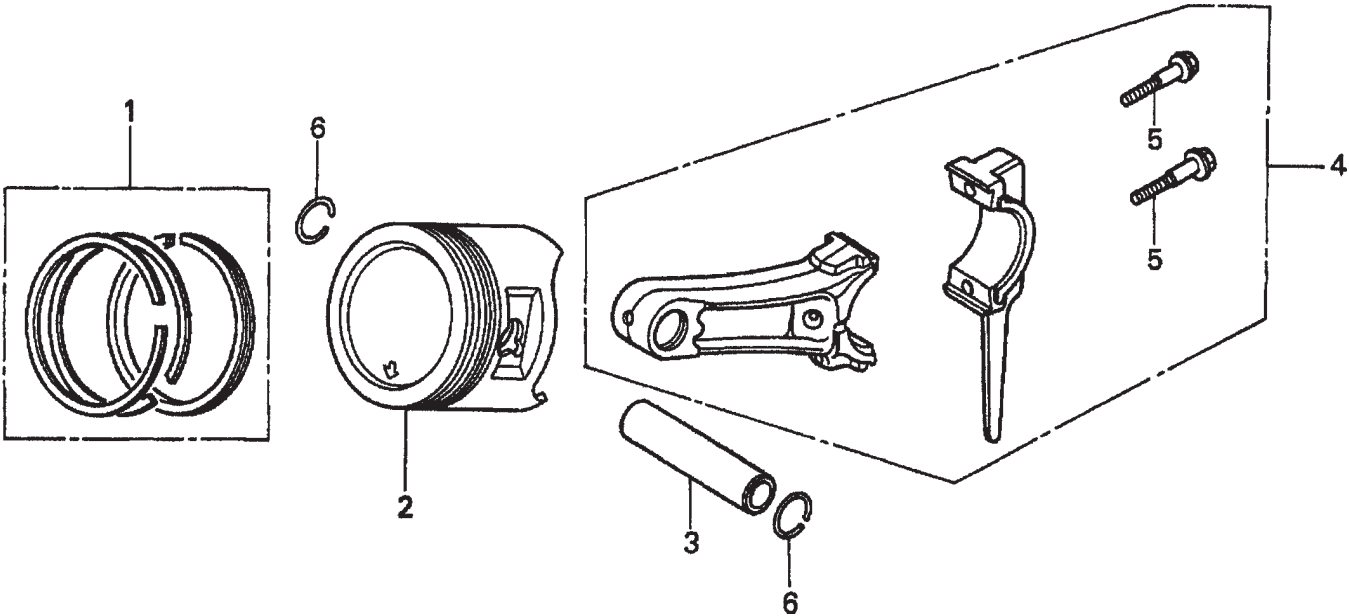

## HONDA GX200QXC9 — PISTON ASSY.

---

### PISTON ASSY.

<u>NO.</u>	<u>PART NO.</u>	<u>PART NAME</u>	<u>QTY.</u>	<u>REMARKS</u>
1	13010ZL0003	RING SET, PISTON (STANDARD)	1	
1	13011ZL0003	RING SET, PISTON (OS 0.25)	1	
1	13012ZL0003	RING SET, PISTON (OS 0.50)	1	
1	13013ZL0003	RING SET, PISTON (0.75)	1	
2	13101ZL0000	PISTON (STANDARD)	1	
2	13102ZL0000	PISTON (OS 0.25)	1	
2	13103ZL0000	PISTON (OS 0.50)	1	
2	13104ZL0000	PISTON (0.75)	1	
3	13111ZE1000	PIN, PISTON	1	
4	132A0ZE1000	ROD ASSEMBLY, CONNECTING (US 0.25)	1	
4	13200ZE1010	ROD ASSEMBLY, CONNECTING	1	
5	90001ZE1000	BOLT, CONNECTING ROD	2	
6	90551ZE1000	CLIP, PISTON PIN 18MM	2	

# HONDA GX200QXC9 — RECOIL STARTER ASSY.

RECOIL STARTER ASSY.

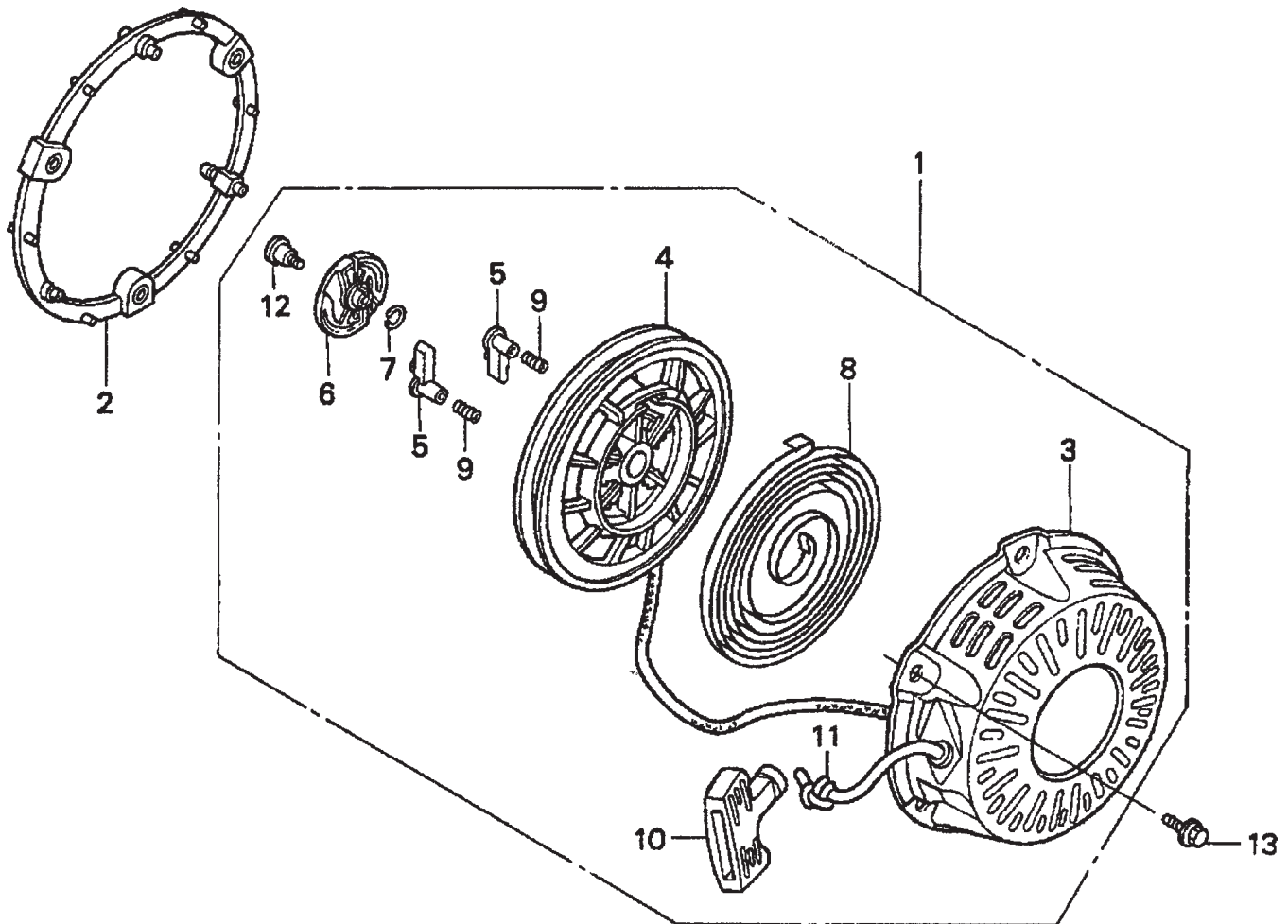

## HONDA GX200QXC9 — RECOIL STARTER ASSY.

---

### RECOIL STARTER ASSY.

<u>NO.</u>	<u>PART NO.</u>	<u>PART NAME</u>	<u>QTY.</u>	<u>REMARKS</u>
1	28400ZH8013ZA	STARTER ASSY., RECOIL *R8* BRIGHT RED	1	INCLUDES ITEMS W/*
2	28405ZL0000ZB	SPACER, RECOIL STARTER MOUNTING *R8* BRIGHT RED	1	
3*	28410ZH8003ZA	CASE, RECOIL STARTER *R8* BRIGHT RED	1	
4*	28420ZH8013	REEL, RECOIL STARTER	1	
5*	28422ZH8013	RATCHET, STARTER	2	
6*	28433ZH8003	GUIDE, RATCHET	1	
7*	28441ZH8003	SPRING, FRICTION	1	
8*	28442ZH8003	SPRING, RECOIL STARTER	1	
9*	28443ZH8003	SPRING, RETURN	2	
10*	28461ZH8003	KNOB, RECOIL STARTER	1	
11*	28462ZH8003	ROPE, RECOIL STARTER	1	
12*	90003ZH8003	SCREW, SETTING	1	
13	957000601800	BOLT, FLANGE 6 X18	3	

## **HONDA GX200QXC9 — GASKET KIT ASSY.**

---

GASKET KIT ASSY.

NO ILLUSTRATION AVAILABLE

## HONDA GX200QXC9 — GASKET KIT ASSY.

---

### GASKET KIT ASSY.

<u>NO.</u>	<u>PART NO.</u>	<u>PART NAME</u>	<u>QTY.</u>	<u>REMARKS</u>
	06111ZL0000	GASKET KIT .....	1 .....	INCLUDES ITEMS W/*
1*	11381ZL0000	GASKET, CASE COVER	1	
2*	12251ZL0003	GASKET, CYLINDER HEAD	1	
3*	12391ZE1000	GASKET, CYLINDER HEAD COVER	1	
4*	15625ZE1003	GASKET, OIL FILLER CAP	1	
5*	16212ZH8800	GASKET, INSULATOR	1	
6*	16221ZH8800	GASKET, CARBURETOR	1	
7*	18381ZH8800	GASKET, MUFFLER	1	

# HONDA GX200QXC9 — LABELS ASSY.

LABELS ASSY.

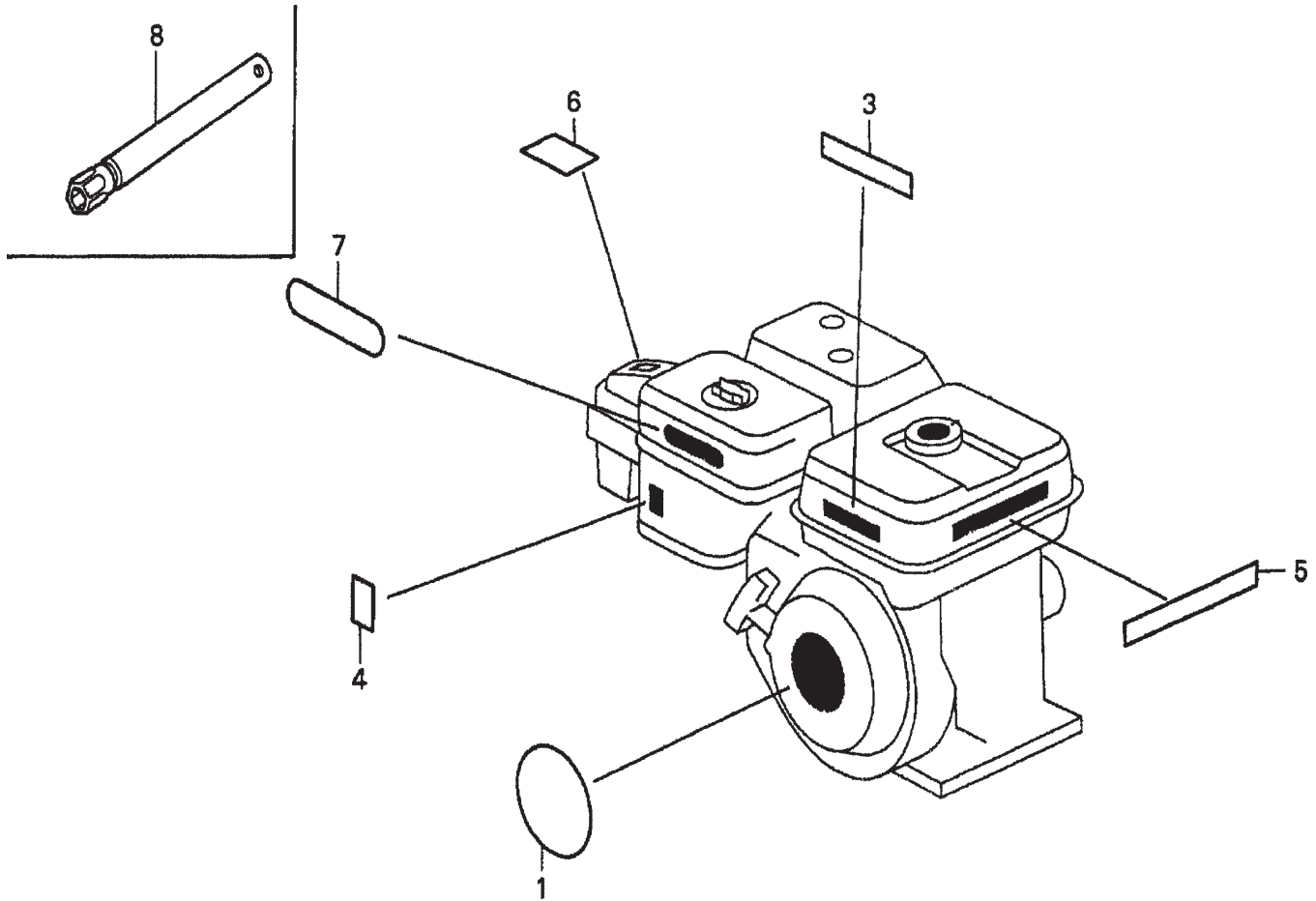



## HONDA GX200QXC9 — LABELS ASSY.

---

### LABELS ASSY.

<u>NO.</u>	<u>PART NO.</u>	<u>PART NAME</u>	<u>QTY.</u>	<u>REMARKS</u>
1	87521ZL0010	EMBLEM	1	
3	87522ZH9000	LABEL, CAUTION	1	
4	87528ZE1810	MARK, CHOKE	1	
5	87532ZH8810	MARK, OIL ALERT (E)	1	
6	87534ZE1841	LABEL, AIR CLEANER CAUTION	1	
7	87535ZE1840	MARK, AIR CLEANER SALES POINT	1	
8	89218ZE1000	WRENCH, SPARK PLUG	1	