

PARTS MANUAL



**WHISPERWATT™ SERIES
MODEL DCA70SSIU4F
60HZ GENERATOR
(ISUZU BJ-4JJ1X DIESEL ENGINE)**

PARTS LIST NO. M2871300114I

Revision #5 (04/14/22)



THIS MANUAL MUST ACCOMPANY THE EQUIPMENT AT ALL TIMES.

DCA70SSIU4F 60 Hz Generator

Explanation Of Code In Remarks Column.....	4
Suggested Spare Parts	5

Component Drawings

Generator Assembly	6–7
Control Panel Assembly	8–9
Control Box Assembly	10–15
Engine And Radiator Assembly.....	16–19
Output Terminal Assembly.....	20–23
Battery Assembly.....	24–25
Muffler 1 Assembly	26–29
Muffler 2 Assembly	30–31
Fuel Tank Assembly.....	32–33
Enclosure Assembly	34–39
Rubber Seals Assembly	40–41
Battery Charger Assembly (Option).....	42–43
Jacket Water Heater Assembly (Option).....	44–45
Nameplate And Decals Assembly	46–49

NOTICE

Specifications and part numbers are subject to change without notice.

EXPLANATION OF CODE IN REMARKS COLUMN

The following section explains the different symbols and remarks used in the Parts section of this manual. Use the help numbers found on the back page of the manual if there are any questions.

NOTICE

The contents and part numbers listed in the parts section are subject to change **without notice**. Multiquip does not guarantee the availability of the parts listed.

SAMPLE PARTS LIST

NO.	PART NO.	PART NAME	QTY.	REMARKS
1	12345	BOLT	1	INCLUDES ITEMS W/%
2%		WASHER, 1/4 IN.		NOT SOLD SEPARATELY
2%	12347	WASHER, 3/8 IN. ...	1	MQ-45T ONLY
3	12348	HOSE	A/R	MAKE LOCALLY
4	12349	BEARING	1	S/N 2345B AND ABOVE

NO. Column

Unique Symbols — All items with same unique symbol (@, #, +, %, or >) in the number column belong to the same assembly or kit, which is indicated by a note in the “Remarks” column.

Duplicate Item Numbers — Duplicate numbers indicate multiple part numbers, which are in effect for the same general item, such as different size saw blade guards in use or a part that has been updated on newer versions of the same machine.

NOTICE

When ordering a part that has more than one item number listed, check the remarks column for help in determining the proper part to order.

PART NO. Column

Numbers Used — Part numbers can be indicated by a number, a blank entry, or TBD.

TBD (To Be Determined) is generally used to show a part that has not been assigned a formal part number at the time of publication.

A blank entry generally indicates that the item is not sold separately or is not sold by Multiquip. Other entries will be clarified in the “Remarks” Column.

QTY. Column

Numbers Used — Item quantity can be indicated by a number, a blank entry, or A/R.

A/R (As Required) is generally used for hoses or other parts that are sold in bulk and cut to length.

A blank entry generally indicates that the item is not sold separately. Other entries will be clarified in the “Remarks” Column.

REMARKS Column

Some of the most common notes found in the “Remarks” Column are listed below. Other additional notes needed to describe the item can also be shown.

Assembly/Kit — All items on the parts list with the same unique symbol will be included when this item is purchased.

Indicated by:

“INCLUDES ITEMS W/(unique symbol)”

Serial Number Break — Used to list an effective serial number range where a particular part is used.

Indicated by:

“S/N XXXXX AND BELOW”

“S/N XXXX AND ABOVE”

“S/N XXXX TO S/N XXX”

Specific Model Number Use — Indicates that the part is used only with the specific model number or model number variant listed. It can also be used to show a part is NOT used on a specific model or model number variant.

Indicated by:

“XXXXX ONLY”

“NOT USED ON XXXX”

“Make/Obtain Locally” — Indicates that the part can be purchased at any hardware shop or made out of available items. Examples include battery cables, shims, and certain washers and nuts.

“Not Sold Separately” — Indicates that an item cannot be purchased as a separate item and is either part of an assembly/kit that can be purchased, or is not available for sale through Multiquip.

SUGGESTED SPARE PARTS

DCA70SSIU4F PORTABLE GENERATOR WITH ISUZU BJ-4JJ1X DIESEL ENGINE

1 to 3 units

QTY.	P/N	DESCRIPTION
1	M2311500503	RADIATOR HOSE, UPPER
1	M2311500603	RADIATOR HOSE, LOWER
5	8980188580	CARTRIDGE OIL FILTER
5	8983129150	FUEL FILTER (MAIN)
5	8983129180	FUEL FILTER ELEMENT, MAIN
5	8980758553	FUEL FILTER (PRE)
5	8980742881	FUEL FILTER ELEMENT, PRE
5	8980714010	FUEL FEED PUMP FILTER
2	0605505070	FUEL TANK CAP
5	0602046365	ELEMENT, AIR CLEANER, PRIMARY
5	Y0602046634	ELEMENT, AIR CLEANER, SECONDARY
1	8981694030	DEF FILTER ELEMENT
1	0602103092	LAMP, ALARM RED
1	8973629260	FAN BELT
1	0601808803	CIRCUIT BREAKER, 1P 20A
1	0601808804	CIRCUIT BREAKER, 2P 50A
1	LY2DUS12VDC	RELAY
2	0601802133	FUSE, 5A
2	0601802149	FUSE, 10A
2	0601806645	FUSE, 10A
2	0601806671	FUSE, 15A
2	Y0601806646	FUSE, 20A
2	0601806644	FUSE, 30A
2	0601806640	FUSE, 65A

NOTICE

Part numbers on this Suggested Spare Parts list may supersede/replace the part numbers shown in the following parts lists.

GENERATOR ASSY.

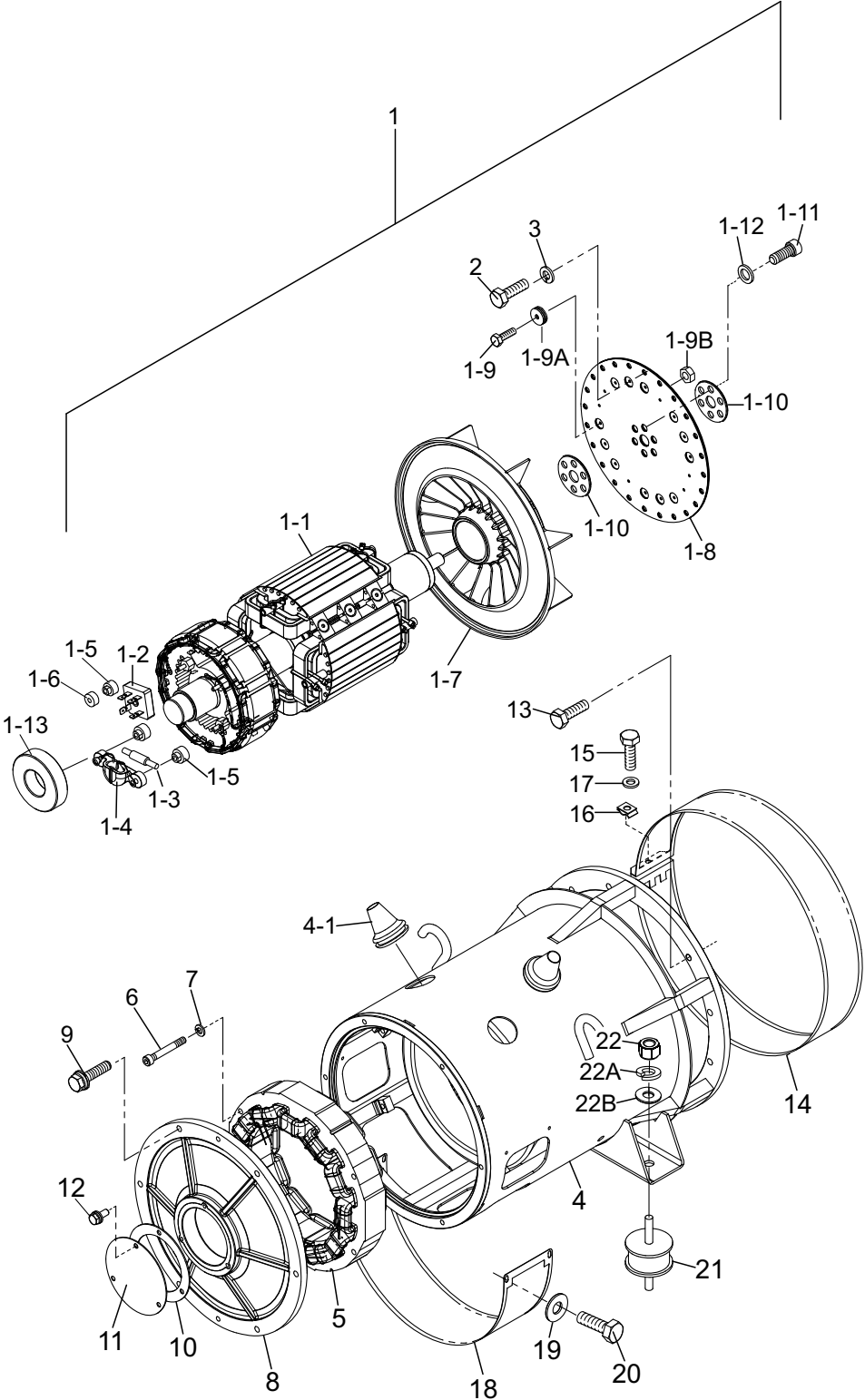

GENERATOR ASSY.

<u>NO.</u>	<u>PART NO.</u>	<u>PART NAME</u>	<u>QTY.</u>	<u>REMARKS</u>
1	B5110000402	ROTOR ASSY.....	1	INCLUDES ITEMS W/#
1-1#		FIELD ASSY.	1	
1-2#	Y0601820083	RECTIFIER	3	
1-3#	Y0601822664	ZNR	1	
1-4#	B3120100804	HOLDER	1	
1-5#	B3120100704	INSULATOR WASHER	5	
1-6#	B3120100604	INSULATOR WASHER	3	
1-7#	B3111100603	FAN	1	
1-8#	B2163100004	COUPLING DISK.....	3	PURCHASE IT.1-9 AS A SET.
1-9#	Y0019104016	HEX. HEAD BOLT	1	
1-9A#	B2163700004	BALANCING WEIGHT	1	
1-9B#	Y0204104000	NUT	1	
1-10#	B3163200104	COUPLING WASHER	2	
1-11#	Y0342612030	HEX. SOCKET HEAD CAP SCREW	6	
1-12#	Y0046512000	WASHER, FLAT	6	
1-13#	Y0071906309	BEARING	1	
2	Y0343204080	HEX. HEAD BOLT	8	
3	EM923344	WASHER, LOCK.....	8	REPLACES P/N 0043604000
4	B5130000303	STATOR ASSY.....	1	INCLUDES ITEMS W/\$
4-1\$	0845041904	GROMMET	2	
5	B3137000803	FIELD ASSY., EXCITER	1	
6	Y0016008060	HEX. SOCKET HEAD CAP SCREW	4	
7	Y0042508000	WASHER, LOCK	4	
8	B3153000513	END BRACKET	1	
9	Y0017108035	HEX. HEAD BOLT	6	
10	B3153400504	PACKING	1	
11	B3153400404	COVER, BEARING	1	
12	Y0017106016	HEX. HEAD BOLT	3	
13	0105091025	HEX. HEAD BOLT.....	12	REPLACES P/N 0010310025
13A	030210250	WASHER, LOCK.....	12	REPLACES P/N 0042510000
14	B5131300004	COVER, END BRACKET	1	
15	Y0340406040	HEX. HEAD BOLT	1	
16	020106050	U-NUT.....	1	REPLACES P/N 0600815000
17	952404470	WASHER, FLAT.....	1	REPLACES P/N 0041206000
18	B3131300804	COVER, END BRACKET	1	
19	Y0029205012	HEX. HEAD BOLT	4	
20	0401450050	WASHER, FLAT.....	4	REPLACES P/N 0041205000
21	Y0605000402	RUBBER SUSPENSION	2	
22	Y0030012000	HEX. NUT	2	
22A	Y0040012000	WASHER, LOCK	2	
22B	031112230	WASHER, FLAT.....	2	REPLACES P/N 0041212000

CONTROL PANEL ASSY.

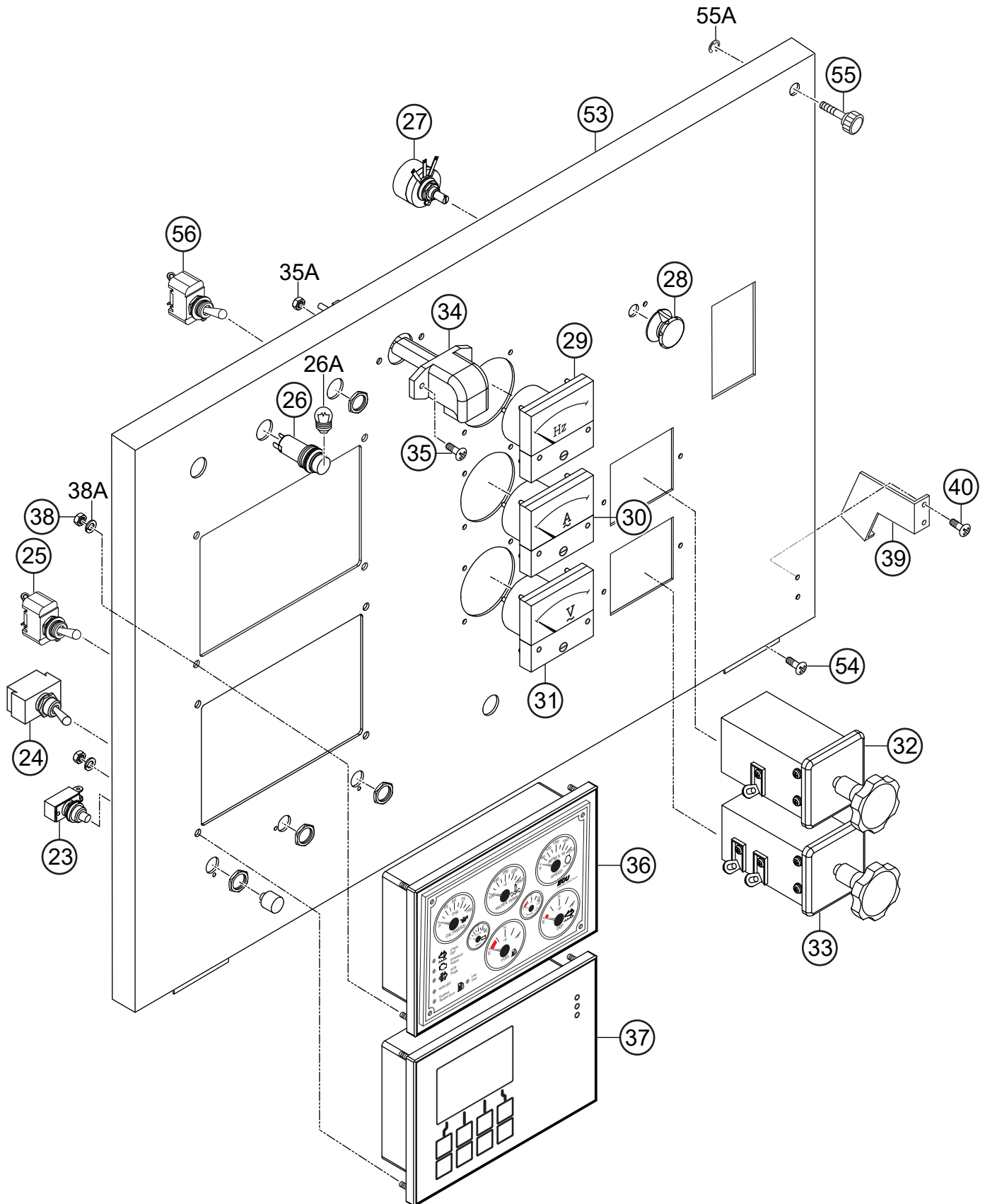

CONTROL PANEL ASSY.

<u>NO.</u>	<u>PART NO.</u>	<u>PART NAME</u>	<u>QTY.</u>	<u>REMARKS</u>
23	0601831205	PUSH BUTTON SWITCH	1	
24	82608	TOGGLE SWITCH	1	REPLACES P/N 0601831340
25	0601830710	TOGGLE SWITCH	1	
26	0602103092	ALARM LAMP	1	INCLUDES ITEM W/\$ S/N 7356142 AND BELOW
26	Y0601814453	LED LAMP	1	S/N 7356143 AND ABOVE
26A\$	0602103092	BULB, 18V	1	REPLAES P/N 0601810277 S/N 7356142 AND BELOW
27	0601840073	RHEOSTAT (VR) 2W 1K OHM	1	
28	0601840100	KNOB	1	REPLACES P/N 0601840121
29	Y0601807631	FREQUENCY METER, 240V 45~65HZ	1	S/N 7353967 AND BELOW
29	0601807641	FREQUENCY METER, 240V 45~65HZ	1	S/N 7353968 AND ABOVE
30	Y0601817034	AC AMMETER, 0~150A/300A:5A	1	S/N 7353967 AND BELOW
30	0601808987	AC AMMETER, 0~150A/300A:5A	1	S/N 7353968 AND ABOVE
31	0601806947	AC VOLTMETER, 600V	1	S/N 7353967 AND BELOW
31	0601806859	AC VOLTMETER, 600V	1	S/N 7353968 AND ABOVE
32	0601801040	CHANGE-OVER SWITCH, AMMETER	1	
33	0601801041	CHANGE-OVER SWITCH, VOLTMETER	1	
34	Y0601810170	PANEL LIGHT, 12V	1	
35	0027104020	MACHINE SCREW	2	
35A	OEMAA8	SELF-LOCKING NUT	2	REPLACES P/N 0207004000
36	Y0602120569	GAUGE UNIT ASSY.	1	S/N 7355077 AND BELOW
36	Y0602120901	GAUGE UNIT ASSY., ECU670	1	S/N 7355078 AND ABOVE
37	Y0602203040	CONTROLLER, ECU835	1	S/N 7355077 AND BELOW
37	Y0602203070	CONTROLLER, ECU845	1	S/N 7355078 AND ABOVE
38	Y0206707000	HEX. NUT	8	
38A	Y0044807000	WASHER, LOCK	8	
39	M1224100104	STOPPER	1	
40	0027105015	MACHINE SCREW	2	
53	M2224000203	CONTROL PANEL	1	
54	0027105015	MACHINE SCREW	4	
55	M9220100004	SET SCREW	2	
55A	0080200007	E-SNAP RING	2	
56	0601830710	PANEL LIGHT SWITCH	1	

CONTROL BOX ASSY.

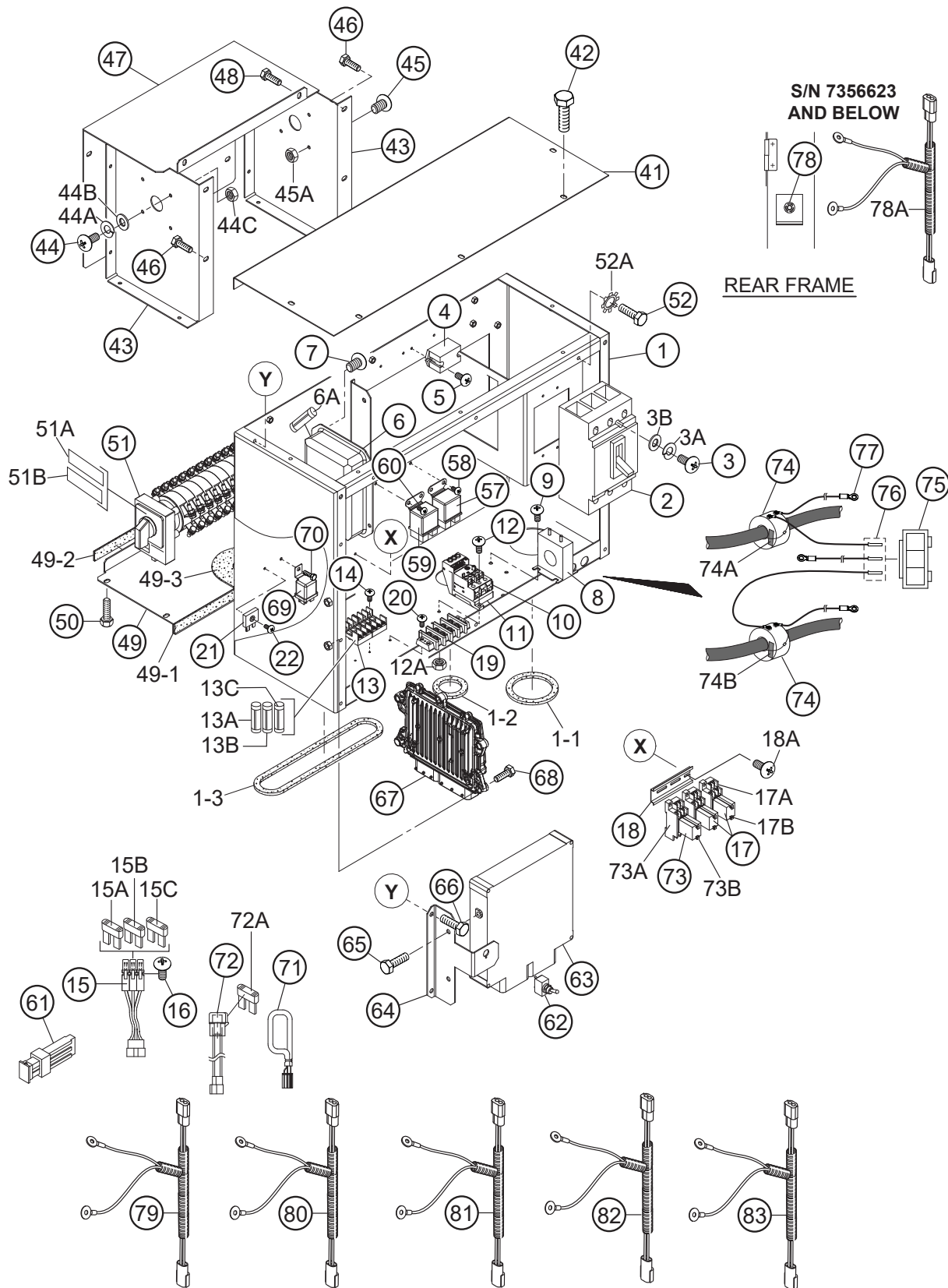

CONTROL BOX ASSY.

<u>NO.</u>	<u>PART NO.</u>	<u>PART NAME</u>	<u>QTY.</u>	<u>REMARKS</u>
1	M2214000402	CONTROL BOX	1	
1-1	Y0411100260	EDGE TRIM	2	
1-2	Y0411100170	EDGE TRIM	1	
1-3	Y0411100630	EDGE TRIM	2	
2	Y0601808833	CIRCUIT BREAKER, 3P 200A	1	
3	0021004070	MACHINE SCREW	2	
3A	0040004000	WASHER, LOCK	2	
3B	58042	WASHER, FLAT	2	REPLACES P/N 0041204000
4	0601823863	RELAY UNIT	2	
5	0027104010	MACHINE SCREW	4	
6	Y0601820638	AUTOMATIC VOLTAGE REGULATOR	1	INCLUDES ITEMS W/#
6A#	Y0601806683	FUSE, 250V 8A	1	
7	0027105015	MACHINE SCREW	4	
8	Y0601809693	CURRENT TRANSFORMER, 150/5A	3	
9	011808015	MACHINE SCREW	6	REPLACES P/N 0027106015
10	Y0601820839	OVER CURRENT RELAY	1	
11	Y0601820844	OVER CURRENT RELAY BASE	1	
12	0027103020	MACHINE SCREW	2	
12A	0207003000	HEX. NUT	2	
13	Y0601802214	HOLDER, FUSE	1	
13A	0601802133	FUSE, 5A	1	
13B	0601802149	FUSE, 10A	2	
13C	0601806671	FUSE, 15A	3	S/N 7354017 AND BELOW
13C	0601806671	FUSE, 15A	2	S/N 7354018 AND ABOVE
13C	0601806653	FUSE, 20A	1	S/N 7354018 AND ABOVE
14	0027103020	MACHINE SCREW	2	
15	M3214601004	HOLDER, FUSE	1	
15A	0601806645	FUSE, 10A	1	
15B	Y0601806646	FUSE, 20A	1	
15C	0601806644	FUSE, 30A	1	
15D	M9501400404	DECAL: FUSE HOLDER	1	
16	Y0027203035	MACHINE SCREW	2	
17	LY2DUS12VDC	RELAY	2	REPLACES P/N 0601827656
17A	PTF08A	BASE	2	REPLACES P/N 0601823109
17B	PYCA1	CLIP	4	REPLACES P/N 0601824400
18	Y0290000100	RAIL	1	
18A	0027104010	MACHINE SCREW	2	
19	0601815153	TERMINAL BLOCK	1	
20	0027104020	MACHINE SCREW	2	
21	0601821370	RECTIFIER	1	REPLACES P/N 0601823240
22	0027104020	MACHINE SCREW	1	
41	M2214500104	CONTROL BOX COVER	1	
42	011106015	HEX. HEAD BOLT	8	REPLACES P/N 0016906015
43	M2213602704	SWITCH BRACKET	2	

CONTROL BOX ASSY. (CONT'D.)

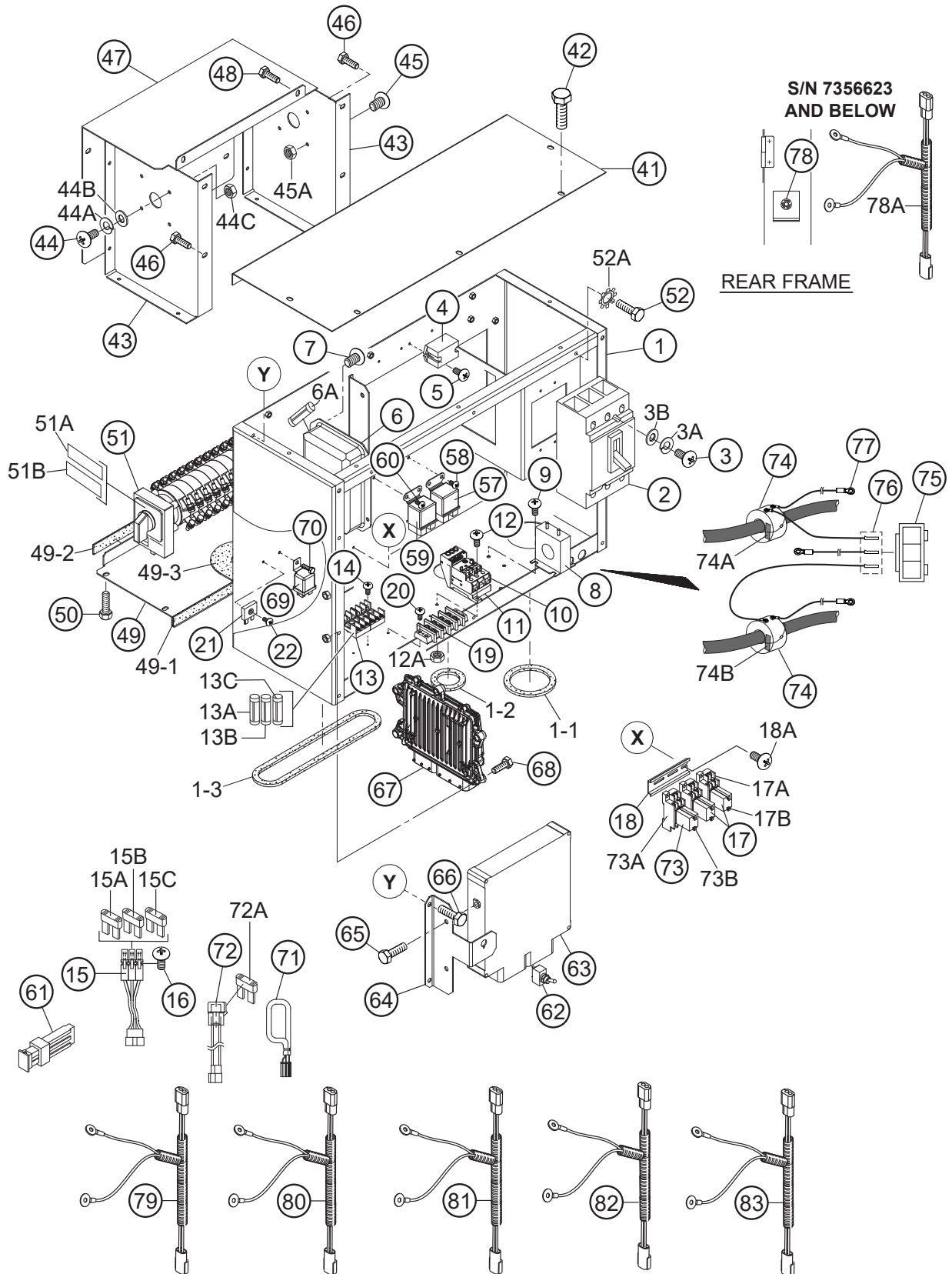

CONTROL BOX ASSY. (CONT'D.)

<u>NO.</u>	<u>PART NO.</u>	<u>PART NAME</u>	<u>QTY.</u>	<u>REMARKS</u>
44	0021004040	MACHINE SCREW	4	
44A	0040004000	WASHER, LOCK	4	
44B	58042	WASHER, FLAT	4	REPLACES P/N 0041204000
44C	OEMAA8	HEX. NUT	4	REPLACES P/N 0207004000
45	0027104015	MACHINE SCREW	4	
45A	OEMAA8	HEX. NUT	4	REPLACES P/N 0207004000
46	011106015	HEX. HEAD BOLT	4	REPLACES P/N 0016906015
47	M2213602804	SWITCH COVER	1	
48	011106015	HEX. HEAD BOLT	6	REPLACES P/N 0016906015
49	M2213602904	SWITCH COVER	1	
49-1	0228800165	SEAL RUBBER	1	
49-2	0228800115	SEAL RUBBER	1	
49-3	0317700180	WEATHER STRIP	1	
50	011106015	HEX. HEAD BOLT	4	REPLACES P/N 0016906015
51	M2270100104	SELECTOR SWITCH	1	
51A	M2550001604	DECAL: SELECTOR SWITCH NUMBER....	1	M25000160
51B	M2550001704	DECAL: SELECTOR SWITCH NUMBER....	1	M25000170
52	011106015	HEX. HEAD BOLT	10	REPLACES P/N 0016906015
52A	0040506000	TOOTHED WASHER	1	
57	8944001061	RELAY, STARTER	1	REPLACES P/N 8942481610
58	011808015	MACHINE SCREW	2	REPLACES P/N 0027106015
59	8970119490	RELAY, GLOW PLUG.....	1	REPLACES P/N 0602202685
60	011808015	MACHINE SCREW	2	REPLACES P/N 0027106015
61	0601806640	FUSE, 65A	1	
62	0601830762	FUEL PUMP SWITCH	1	
63	8982995492	ENGINE CONTROLLER, ECM	1	REPLACES P/N Y0602203011 S/N 7354017 AND BELOW
63	8975055470	ENGINE CONTROLLER, ECM	1	REPLACES P/N 8983627510 S/N 7354018 AND ABOVE
64	M2352600004	BRACKET	1	
65	011008020	HEX. HEAD BOLT	4	REPLACES P/N 0016908020
66	011106015	HEX. HEAD BOLT	2	REPLACES P/N 0016906015
67	8982454051	DOSING CONTROL UNIT	1	REPLACES P/N Y0602203021 S/N 7354017 AND BELOW
67	8983243390	DOSING CONTROL UNIT	1	REPLACES P/N Y0602203024 S/N 7354018 AND ABOVE
68	011208030	HEX. HEAD BOLT	4	REPLACES P/N 0016908030
69	5825500290	RELAY	5	REPLACES P/N 0602201400
70	0027105015	HEX. HEAD BOLT	5	
71	M2267600004	RESISTOR ASSY.	1	
72	C3558201704	FUSE HOLDER UNIT	1	REPLACES P/N M2357202104
72A	0601806645	FUSE, 10A	1	

CONTROL BOX ASSY. (CONT'D.)

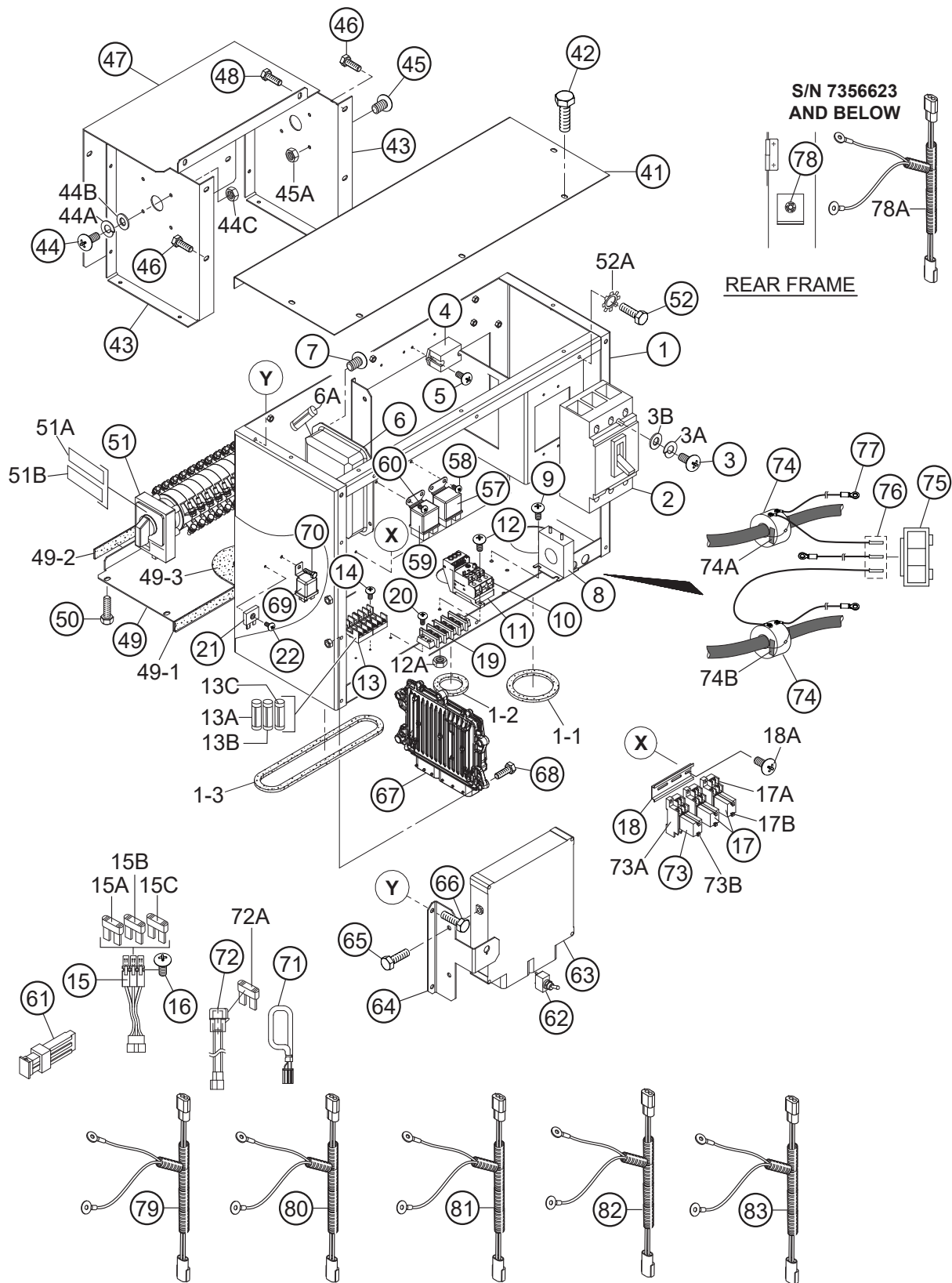

CONTROL BOX ASSY. (CONT'D.)

<u>NO.</u>	<u>PART NO.</u>	<u>PART NAME</u>	<u>QTY.</u>	<u>REMARKS</u>
73	LY2DUS12VDC	RELAY	1	REPLACES P/N 0601827656 S/N 7353902 AND ABOVE
73A	PTF08A	BASE.....	1	REPLACES P/N 0601823109 S/N 7353902 AND ABOVE
73B	PYCA1	CLIP	2	REPLACES P/N 0601824400 S/N 7353902 AND ABOVE
74	Y0601872910	CURRENT TRANSFORMER	2	S/N 7355078 AND ABOVE
74A	M9521001604	DECAL: CT4.....	1	S/N 7355078 AND ABOVE
74B	M9521001704	DECAL: CT5.....	1	S/N 7355078 AND ABOVE
75	Y0601813924	PLUG.....	1	S/N 7355078 AND ABOVE
76	0601812711	PINS	3	S/N 7355078 AND ABOVE
77	Y0601815586	ROUND TERMINAL	3	S/N 7355078 AND ABOVE
78	Y0601831953	EMERGENCY STOP BUTTON.....	1	S/N 7356623 AND BELOW
78A	M2358201204	WIRE HARNESS, E-STOP	1	S/N 7356623 AND BELOW
79	M2247700304	WIRE HARNESS, GENERATOR	1	S/N 7355077 AND BELOW
79	M2247701304	WIRE HARNESS, GENERATOR	1	S/N 7355078 AND ABOVE
80	M2358200602	WIRE HARNESS, ENGINE	1	
81	M2358200304	WIRE HARNESS, CONTROLLER	1	S/N 7354017 AND BELOW
81	M2358200324	WIRE HARNESS, CONTROLLER	1	S/N 7354018 AND ABOVE
82	M2358200804	WIRE HARNESS, PCV HEATER	1	
83	M2358200904	WIRE HARNESS, PRESSURE SWITCH....	1	S/N 7353902 AND ABOVE

ENGINE AND RADIATOR ASSY.

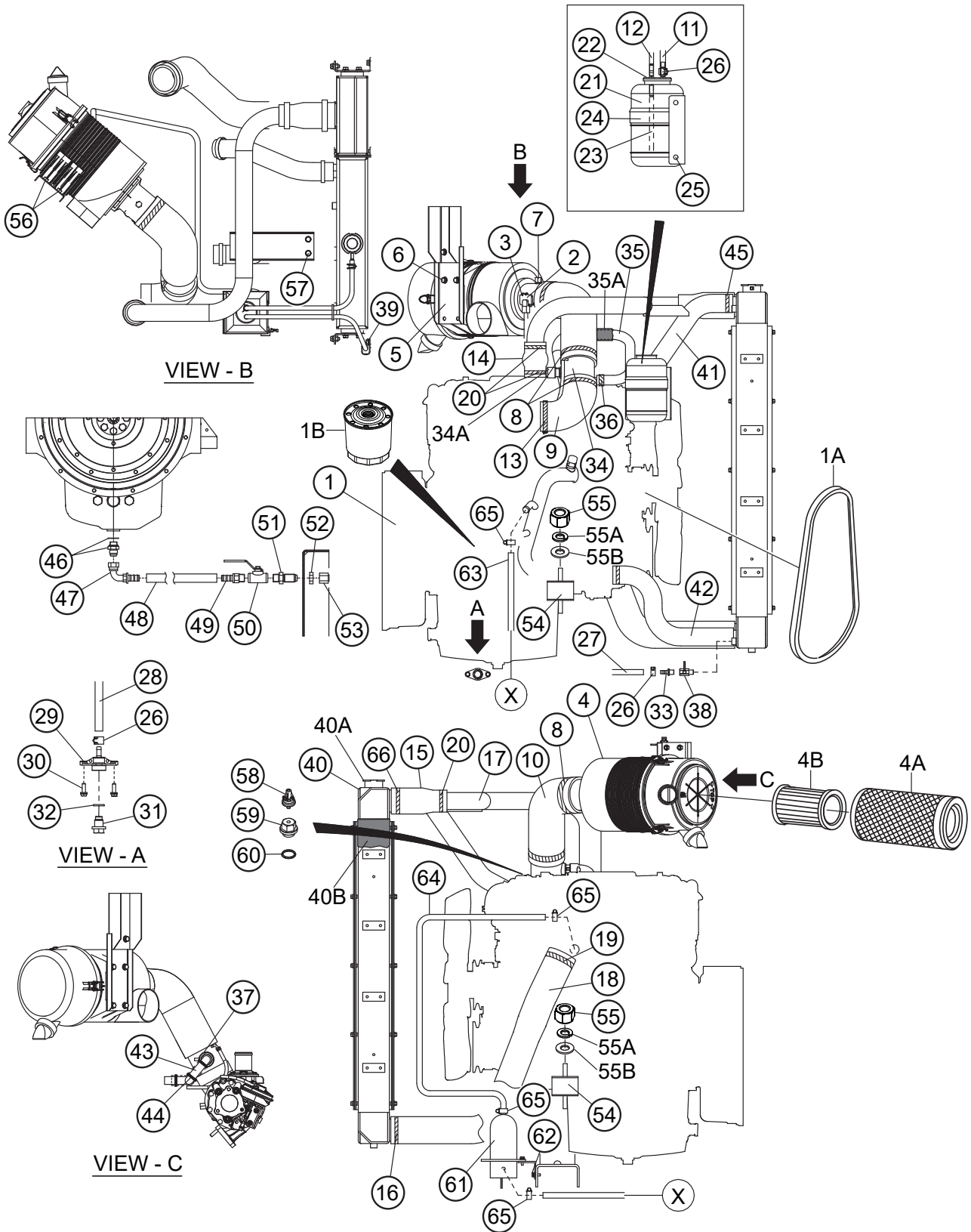

ENGINE AND RADIATOR ASSY.

<u>NO.</u>	<u>PART NO.</u>	<u>PART NAME</u>	<u>QTY.</u>	<u>REMARKS</u>
1	M2924000044	ENGINE, ISUZU 4JJ1X.....	1	INCLUDES ITEMS W/# S/N 7354017 AND BELOW
1	M2924000054	ENGINE, ISUZU 4JJ1X.....	1	INCLUDES ITEMS W/\$ S/N 7354018 AND ABOVE
1A#\$	8973629260	FAN BELT.....	1	REPLACES P/N 0602015256
1B#\$	8980188580	CARTRIDGE, OIL FILTER.....	2	REPLACES P/N Y0602041222
2	8976019670	MAF SENSOR.....	1	REPLACES P/N Y0602047050
3	0027104010	MACHINE SCREW	2	
4	Y0602046578	AIR CLEANER.....	1	INCLUDES ITEMS W/%
4A%	0602046365	ELEMENT, PRIMARY	1	
4B%	Y0602046634	ELEMENT, SECONDARY (SAFETY)	1	
5	M2374200004	AIR CLEANER BRACKET	1	
6	011208025	HEX. HEAD BOLT.....	4	REPLACES P/N 0016908025
7	0602040650	AIR CLEANER INDICATOR	1	
8	0605515225	HOSE BAND	3	
9	M2374100103	AIR CLEANER HOSE	1	
10	M2374100203	AIR CLEANER HOSE	1	
11	0199900500	OVERFLOW HOSE	1	
12	0193601800	OVERFLOW HOSE	1	
13	0605515146	HOSE BAND	1	
14	M2311500703	INTER-COOLER HOSE.....	1	S/N 7355202 AND BELOW
14	Y0602015620	CAC HUMP HOSE.....	1	S/N 7355203 AND ABOVE
15	M2311500803	INTER-COOLER HOSE.....	1	S/N 7355202 AND BELOW
15	Y0602015621	CAC REDUCER.....	1	S/N 7355203 AND ABOVE
16	0605515236	HOSE BAND.....	2	S/N 7355202 AND BELOW
16	0605515236	HOSE BAND.....	1	S/N 7355203 AND ABOVE
17	M2311400004	INTER-COOLER PIPE.....	1	S/N 7355202 AND BELOW
17	M2311400013	INTER-COOLER PIPE.....	1	S/N 7355203 AND ABOVE
18	M2311500903	INTER-COOLER HOSE	1	
19	0605515208	HOSE BAND	1	
20	Y0605515300	HOSE BAND	3	
21	0845031303	RESERVE TANK.....	1	REPLACES P/N M9300000103
22	0802081104	CAP, RESERVE TANK.....	1	REPLACES P/N M9300100003
23	Y0193600165	HOSE	1	
24	M2316100304	BRACKET, RESERVE TANK	1	
25	011008020	HEX. HEAD BOLT.....	2	REPLACES P/N 0016908020
26	0605515189	HOSE BAND	4	
27	0193600500	DRAIN HOSE	1	
28	0199901500	DRAIN HOSE	1	
29	7812014003B	DRAIN JOINT.....	1	REPLACES P/N M2320300103
30	011206020	HEX. HEAD BOLT.....	2	REPLACES P/N 0016906020
31	0802011104	DRAIN BOLT.....	1	REPLACES P/N M9200200004
32	0150000018	O-RING	1	
33	Y0605512192	HOSE JOINT	1	
34	M2374000104	BLOWBY PIPE.....	1	INCLUDES ITEMS W/@
34A@	Y0602044300	PCV HEATER	1	

ENGINE AND RADIATOR ASSY. (CONT'D.)

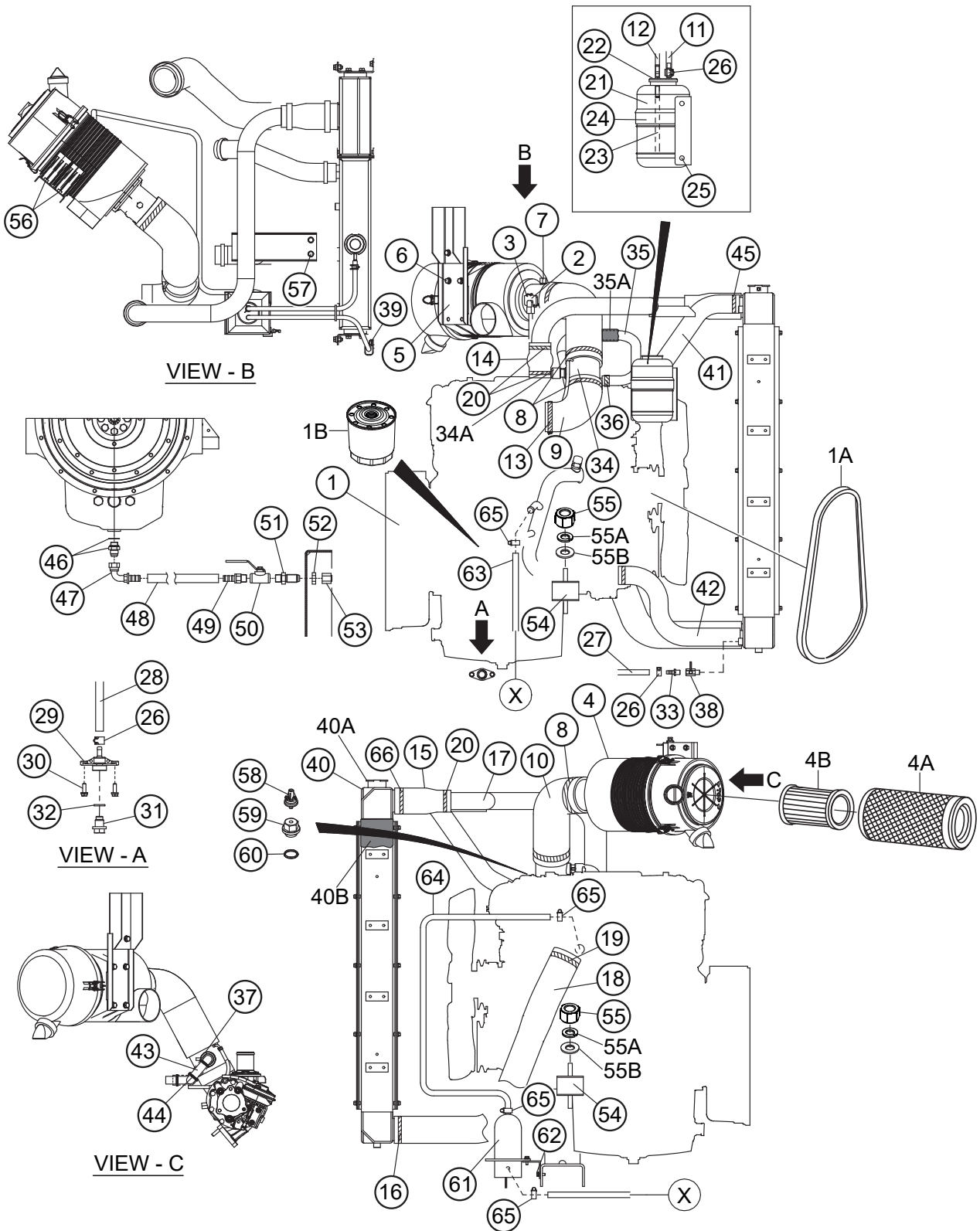

ENGINE AND RADIATOR ASSY. (CONT'D.)

<u>NO.</u>	<u>PART NO.</u>	<u>PART NAME</u>	<u>QTY.</u>	<u>REMARKS</u>
35	M2327200004	BLOWBY HOSE	1	
35A	Y0378500230	AEROFLEX TUBE	1	
36	0605515198	HOSE BAND	1	
37	Y06055153214	HOSE BAND	1	
38	Y0605511394	MINI BALL VALVE	1	
39	0602220911	CLAMP	2	
40	Y0602012908	RADIATOR AND INTER-COOLER	1	
40A	Y0602015750	CAP, RADIATOR	1	
40B	M2491200204	ACOUSTIC SHEET	2	
41	M2311500503	RADIATOR HOSE, UPPER	1	
42	M2311500603	RADIATOR HOSE, LOWER	1	
43	Y0199000170	TURBO CONTROL HOSE	1	
44	Y0605515104	HOSE BAND	2	
45	0605515147	HOSE BAND	4	
46	0602022581	ADAPTER, 10-M24X2.0	1	
47	0602022561	90° ELBOW	1	
48	Y0269200350	PUSH-LOCK HOSE	1	
49	0603306395	MALE PIPE	1	
50	0605511395	BALL VALVE	1	
51	0603306590	MALE BULKHEAD CONNECTOR	1	
52	0603300285	BULKHEAD LOCKNUT	1	
53	0602021070	CAP	1	
54	Y0605000461	RUBBER SUSPENSION	2	
55	0030012000	HEX. NUT	2	
55A	0040012000	WASHER, LOCK	2	
55B	Y0602005000	WASHER, FLAT	2	
56	0016908030	HEX. HEAD BOLT	2	REPLACES P/N 011208030
57	0016908020	HEX. HEAD BOLT	4	REPLACES P/N 011008020
58	8983193760	PRESSURE SWITCH	1	REPLACES P/N Y0602210060 S/N 7353902 AND ABOVE
59	Y0602211628	ADAPTER.....	1	S/N 7353902 AND ABOVE
60	8941236231	PACKING.....	1	REPLACES P/N Y0602021704 S/N 7353902 AND ABOVE
61	EE10814	WATER HEATER.....	1	REPLACES P/N 0602014292 S/N 7355078 AND ABOVE
62	011606025	HEX. HEAD BOLT	2	REPLACES P/N 0016906025 S/N 7355078 AND ABOVE
63	Y0269301440	HOSE	1	S/N 7355078 AND ABOVE
64	Y0269300680	HOSE	1	S/N 7355078 AND ABOVE
65	0605515198	HOSE BAND	4	S/N 7355078 AND ABOVE
66	Y0605515205	HOSE BAND	1	S/N 7355203 AND ABOVE

OUTPUT TERMINAL ASSY.

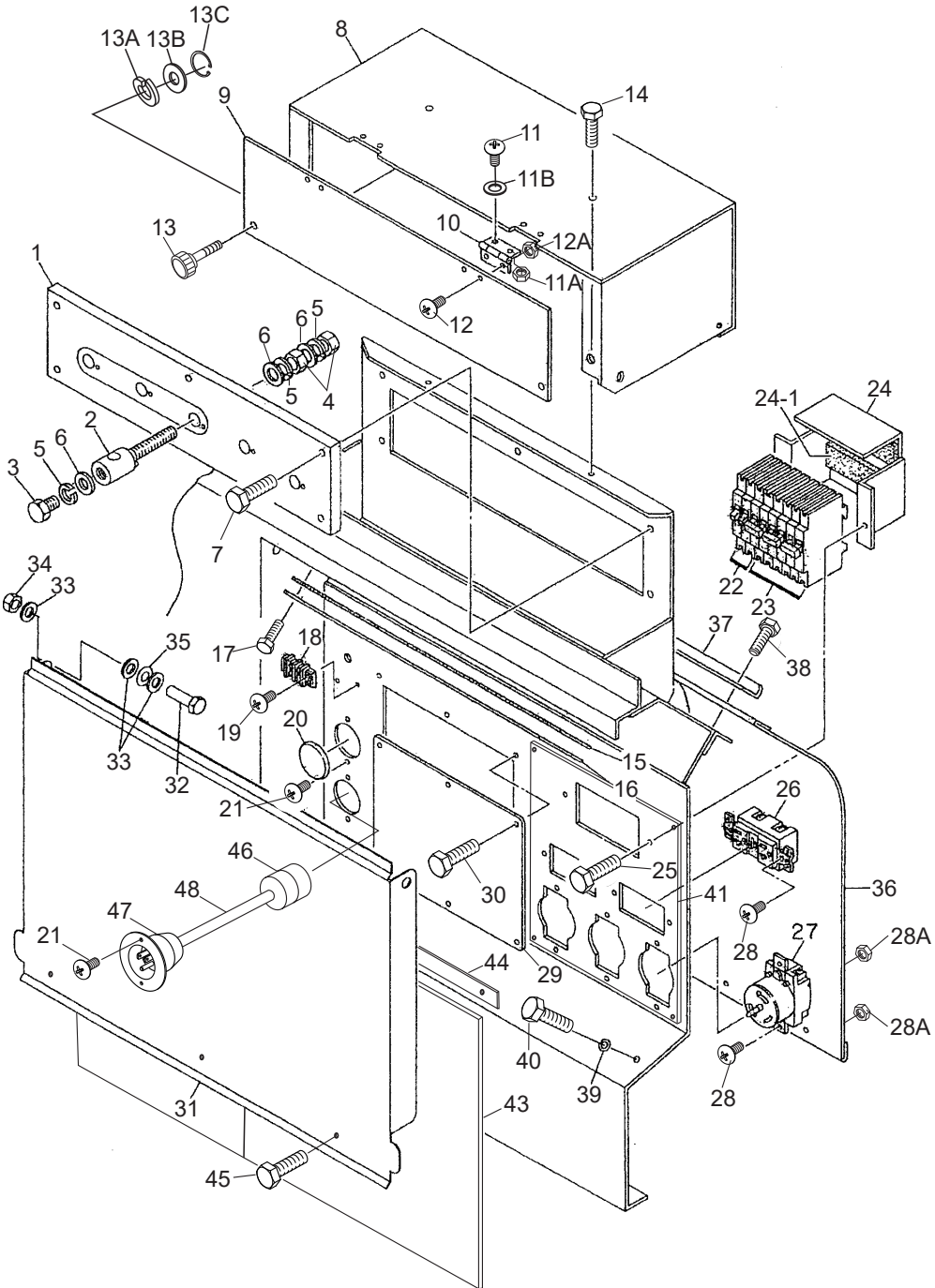

ADD THE FOLLOWING DIGITS AFTER THE PART NUMBER WHEN ORDERING ANY PAINTED PANEL TO INDICATE COLOR OF UNIT:

1-ORANGE	5-BLACK
2-WHITE	6-CATERPILLAR YELLOW
3-SPECTRUM GREY	7-CATO GOLD
4-SUNBELT GREEN	8-RED

THE SERIAL NUMBER MAY BE REQUIRED.

OUTPUT TERMINAL ASSY.

<u>NO.</u>	<u>PART NO.</u>	<u>PART NAME</u>	<u>QTY.</u>	<u>REMARKS</u>
1	M3230700003	TERMINAL PANEL	1	
2	M9220100304	OUTPUT TERMINAL BOLT	5	
3	0801830804	TIE BOLT	5	REPLACES P/N M9220100404
4	0039316000	HEX. NUT	10	
5	0040016000	WASHER, LOCK	15	
6	0401450160	WASHER, FLAT	20	REPLACES P/N 0041416000
7	0012108035	HEX. HEAD BOLT	5	REPLACES P/N 0016908035
8	M2237100103	3-PHASE OUTPUT TERMINAL COVER	1	
9	M3236100104	OUTPUT WINDOW	1	
10	0605010040	HINGE	2	
11	0027103010	MACHINE SCREW	4	
11A	0207003000	HEX. NUT	4	REPLACES P/N 0030003000
11B	0041203000	WASHER, FLAT	4	
12	0027103010	MACHINE SCREW	4	
12A	0207003000	HEX. NUT	4	REPLACES P/N 0030003000
13	M9220100804	SET SCREW	2	
13A	0040006000	WASHER, LOCK	2	
13B	952404470	WASHER, FLAT	2	REPLACES P/N 0041206000
13C	0080200005	E-SNAP RING	2	
14	011106015	HEX. HEAD BOLT	4	REPLACES P/N 0016906015
15	M3236400004	RUBBER, CABLE OUTLET COVER	1	
16	M3236300004	SUPPORTER, CABLE OUTLET COVER	1	
17	011206020	HEX. HEAD BOLT	6	REPLACES P/N 0016906020
18	0601815194	TERMINAL BLOCK	1	
19	0027104015	MACHINE SCREW	2	
20	0603306775	BLIND PLUG	2	S/N 7355077 AND BELOW
20	0603306775	BLIND PLUG	1	S/N 7355078 AND ABOVE
21	0027104015	MACHINE SCREW	4	
22	0601808803	CIRCUIT BREAKER, 1P 20A	2	
23	0601808804	CIRCUIT BREAKER, 2P 50A	3	
24	M1260700304	BREAKER FITTING COVER	1	
24-1	0222100150	CUSHION RUBBER	1	
25	011106015	HEX. HEAD BOLT	2	REPLACES P/N 0016906015
26	Y0601814024	RECEPTACLE, 125V 20AX2.....	2	S/N 7355487 AND BELOW
26	Y0601814034	RECEPTACLE, 125V 20AX2.....	2	S/N 7355488 AND ABOVE
27	0601814014	RECEPTACLE, 250V 50A	3	
28	0027104015	MACHINE SCREW	10	
28A	OEMAA8	HEX. NUT	10	REPLACES P/N 0207004000
29	M2453400004	COVER	1	
30	011106015	HEX. HEAD BOLT	6	REPLACES P/N 0016906015
31	M2237100003	TERMINAL COVER.....	1	S/N 7354617 AND BELOW
31	M2237100403	TERMINAL COVER.....	1	S/N 7354618 AND ABOVE
32	012212045	HEX. HEAD BOLT	2	REPLACES P/N 0010112045
33	031112230	WASHER, FLAT	6	REPLACES P/N 0041212000
34	0030012000	HEX. NUT	2	
35	0605050060	CONICAL LOCK WASHER	2	

OUTPUT TERMINAL ASSY. (CONT'D.)

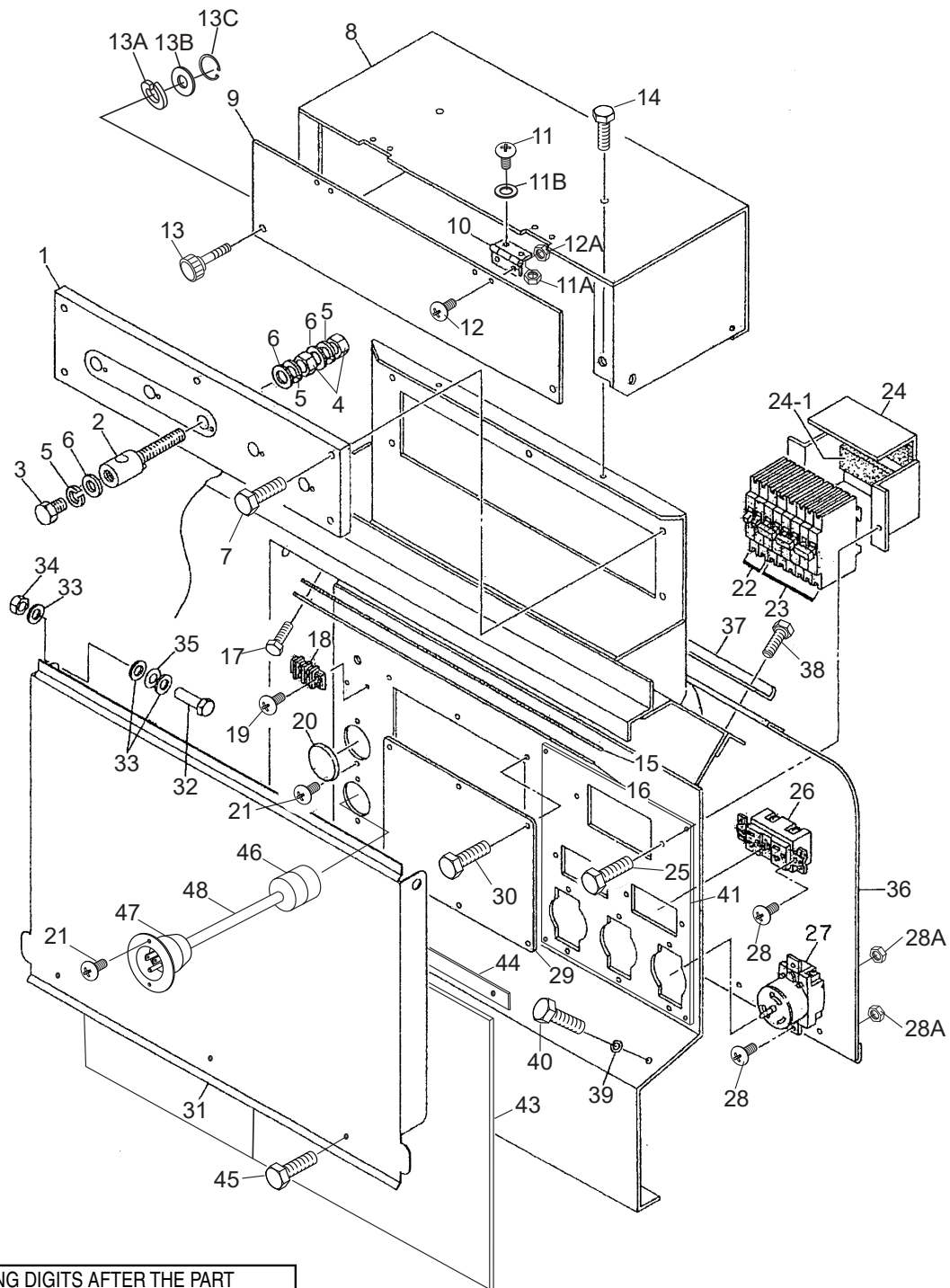

ADD THE FOLLOWING DIGITS AFTER THE PART NUMBER WHEN ORDERING ANY PAINTED PANEL TO INDICATE COLOR OF UNIT:

- | | |
|-----------------|----------------------|
| 1-ORANGE | 5-BLACK |
| 2-WHITE | 6-CATERPILLAR YELLOW |
| 3-SPECTRUM GREY | 7-CATO GOLD |
| 4-SUNBELT GREEN | 8-RED |

THE SERIAL NUMBER MAY BE REQUIRED.

OUTPUT TERMINAL ASSY. (CONT'D.)

<u>NO.</u>	<u>PART NO.</u>	<u>PART NAME</u>	<u>QTY.</u>	<u>REMARKS</u>
36	M1237101204	INSULATING COVER.....	1	REPLACES P/N M4236100604
37	M4236400304	SUPPORTER, INSULATING COVER	1	
38	011106015	HEX. HEAD BOLT	2	REPLACES P/N 0016906015
39	0040508000	TOOTHED WASHER	1	
40	011008020	HEX. HEAD BOLT	1	REPLACES P/N 0016908020
41	M3454200904	RECEPTACLE BOARD	1	S/N 7354618 AND ABOVE
42	011106015	HEX. HEAD BOLT	6	REPLACES P/N 0016906015 S/N 7354618 AND ABOVE
43	M2454700704	RUBBER SHEET.....	1	S/N 7354618 AND ABOVE
44	M2454700804	RUBBER SHEET HOLDER.....	1	S/N 7354618 AND ABOVE
45	011206020	HEX. HEAD BOLT	3	REPLACES P/N 0019206020 S/N 7354618 AND ABOVE
46	0601812527	CONNECTOR	1	S/N 7355078 - 7356642
47	Y0601811177	RECEPTACLE.....	1	S/N 7355078 - 7356642
48	M1358200804	WIRE HARNESS, WATER HEATER	1	S/N 7355078 - 7356642
48	Y0601813078	WATER HEATER CABLE	1	S/N 7356643 AND ABOVE

BATTERY ASSY.

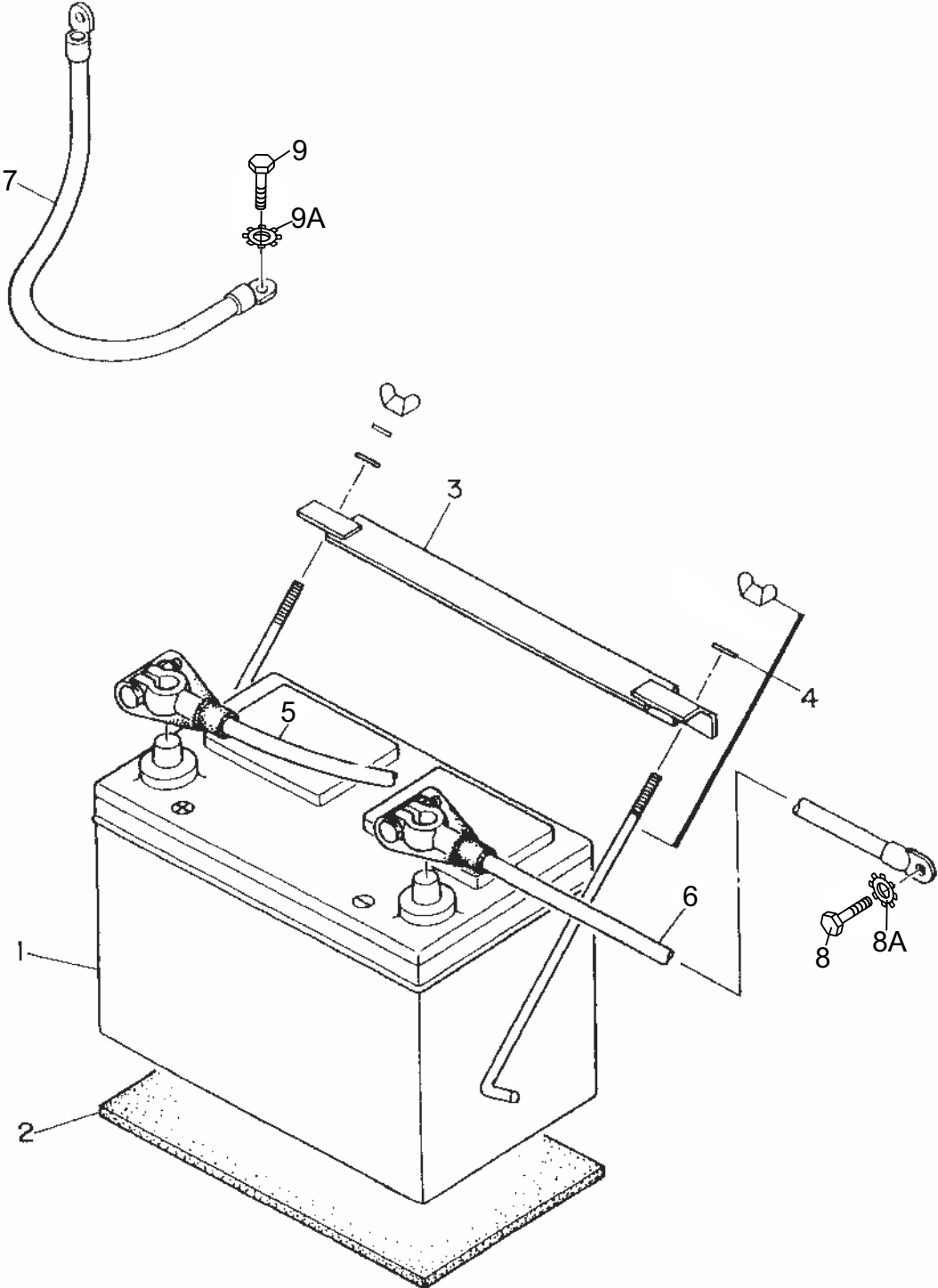

BATTERY ASSY.

<u>NO.</u>	<u>PART NO.</u>	<u>PART NAME</u>	<u>QTY.</u>	<u>REMARKS</u>
1	0602220199	BATTERY	1	S/N 7357053 AND BELOW
1	Y0602221291	BATTERY	1	S/N 7357054 - 7357362
1	0602220199	BATTERY	1	S/N 7357363 AND ABOVE
2	M9310500014	BATTERY SHEET	1	
3	M9103000304	BATTERY BAND	1	
4	0602220920	BATTERY BOLT SET	2	S/N 7357053 AND BELOW
4	0602220921	BATTERY BOLT SET	2	S/N 7357054 - 7357362
4	0602220920	BATTERY BOLT SET	2	S/N 7357363 AND ABOVE
5	M2347400004	BATTERY CABLE	1	
6	M2347400104	BATTERY CABLE	1	
7		CABLE.....	1	MAKE LOCALLY
8	0017112025	HEX. HEAD BOLT	1	
8A	0040512000	TOOTHED WASHER	1	
9	011208025	HEX. HEAD BOLT	1	REPLACES P/N 0016908025
9A	0040508000	TOOTHED WASHER	1	

MUFFLER 1 ASSY.

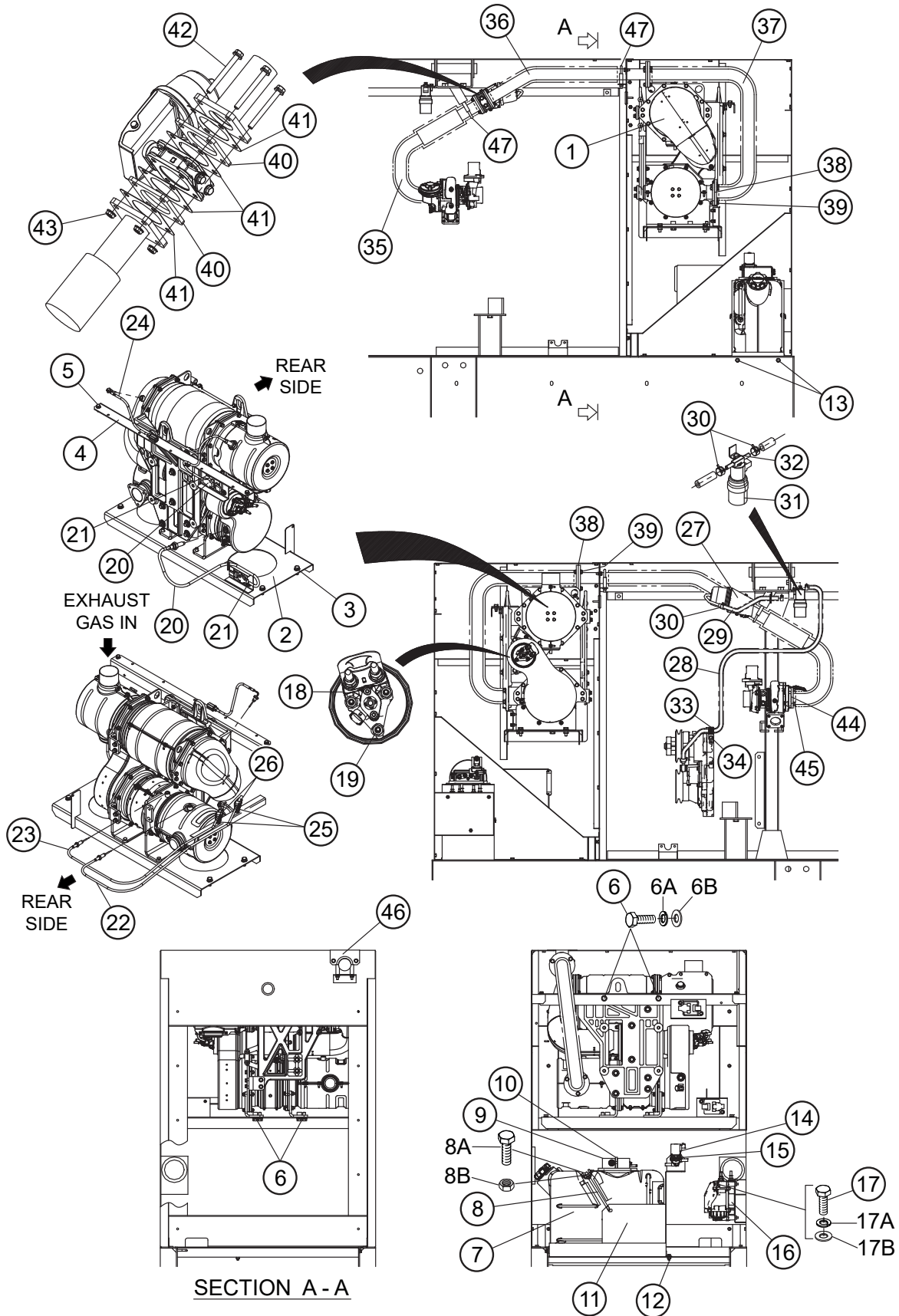

MUFFLER 1 ASSY.

<u>NO.</u>	<u>PART NO.</u>	<u>PART NAME</u>	<u>QTY.</u>	<u>REMARKS</u>
1	8983029372	SCR ASSY.....	1	REPLACES P/N Y0602330322
2	M2331200003	SCR BRACKET	1	
3	0016910025	HEX. HEAD BOLT	4	
4	M2331200104	SCR SUPPORT	1	S/N 7353967 AND BELOW
4	M2331200114	SCR SUPPORT	1	S/N 7353968 AND ABOVE
5	011008020	HEX. HEAD BOLT	2	REPLACES P/N 0016908020
6	0019112030	HEX. HEAD BOLT	6	
6A	0042312000	WASHER, LOCK	6	
6B	0042412000	WASHER, FLAT	6	
7	8982984470	DEF TANK	1	REPLACES P/N Y0602330447
8	0602330441	RETAINER	1	
8A	0602330442	BOLT SCREW	2	
8B	0602330443	HEX. HEAD NUT	2	
9	0602330448	DEF TANK COVER ASSY.	1	
10	0602330443	DEF TANK COVER CLIP	1	
11	M2334300203	DEF TANK BRACKET	1	
12	011008020	HEX. HEAD BOLT	2	REPLACES P/N 0016908020
13	011208025	HEX. HEAD BOLT	2	REPLACES P/N 0016908025
14	8981213061	COOLANT CONTROL VALVE.....	1	REPLACES P/N Y0602330484
15	011008020	HEX. HEAD BOLT	2	REPLACES P/N 0016908020
16	8982688110	DEF SUPPLY MODULE	1	REPLACES P/N Y0602330483
17	Y0013608090	HEX. HEAD BOLT	3	
17A	0040008000	WASHER, LOCK	3	
17B	0401450080	WASHER, FLAT	3	REPLACES P/N 0041208000
18	8982318982	DEF DOSING MODULE.....	1	REPLACES P/N Y0602330474
19	0911801060	HEX. NUT	3	REPLACES P/N Y0602330475
20	8982465062	NOX SENSOR.....	1	REPLACES P/N Y0602330482
20	8982465062	NOX SENSOR.....	2	S/N 7354017 AND BELOW REPLACES P/N Y0602330482
21	011206020	HEX. HEAD BOLT	2	S/N 7354018 AND ABOVE REPLACES P/N 0016906020
21	011206020	HEX. HEAD BOLT	4	S/N 7354017 AND BELOW REPLACES P/N 0016906020
22	8981783581	DOC TEMP SENSOR, FRONT	1	S/N 7354018 AND ABOVE REPLACES P/N 0602330481
23	8981867621	DOC TEMP SENSOR, REAR	1	REPLACES P/N 0602330471
24	8980863290	SCR TEMP SENSOR.....	1	REPLACES P/N 0602330470
25	0602330472	TEMP SENSOR BRACKET	2	
26	011008020	HEX. HEAD BOLT	2	REPLACES P/N 0016908020
27	0602315010	EXHAUST THROTTLE	1	
28	0602315011	VACUUM HOSE	1	
29	0602315012	VACUUM HOSE	1	
30	0602315013	VACUUM HOSE CLIP	4	
31	0602315001	MAGNETIC VALVE	1	
32	011008020	HEX. HEAD BOLT	1	REPLACES P/N 0016908020
33	0602220911	CLAMP	1	
34	011008020	HEX. HEAD BOLT	1	REPLACES P/N 0016908020

MUFFLER 1 ASSY. (CONT'D.)

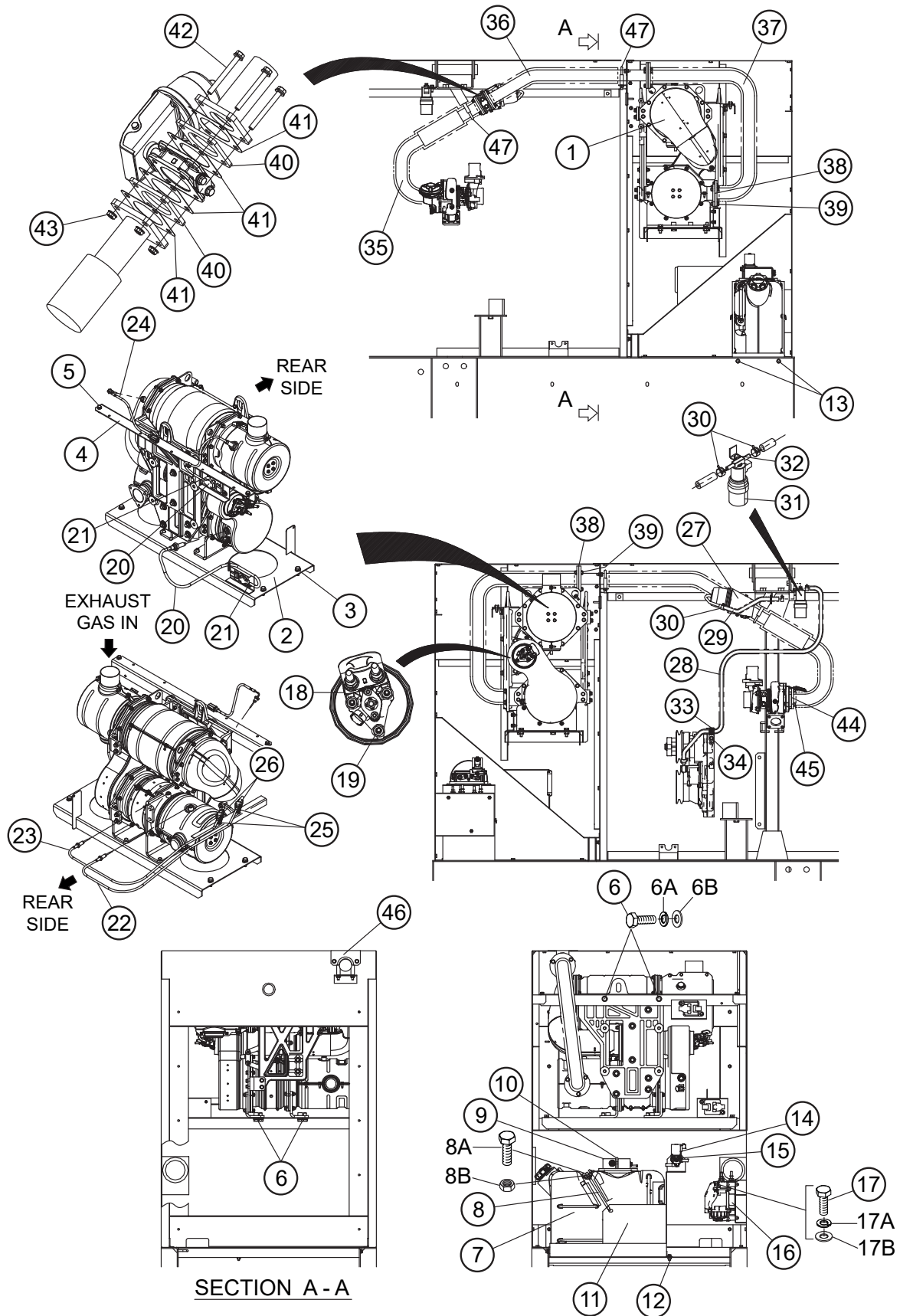

MUFFLER 1 ASSY. (CONT'D.)

<u>NO.</u>	<u>PART NO.</u>	<u>PART NAME</u>	<u>QTY.</u>	<u>REMARKS</u>
35	M2334000303	EXHAUST PIPE	1	
35A	Y0602311160	HEAT SHIELD	1	
36	M2334000603	EXHAUST PIPE	1	
36A	Y0602311161	HEAT SHIELD	1	
37	M2334000504	EXHAUST PIPE	1	
37A	Y0602311162	HEAT SHIELD	1	
38	8973767580	GASKET	2	REPLACES P/N 0602320214
39	0019208035	HEX. HEAD BOLT	6	
39A	020108060	SELF-LOCKING NUT.....	6	REPLACES P/N 0207008000
40	M1334300504	EXHAUST PIPE SPACER	2	
41	8973731080	GASKET	4	REPLACES P/N Y0602320212
42	Y0019108080	HEX. HEAD BOLT	4	
42A	0042308000	WASHER, LOCK	4	
42B	0401450080	WASHER, FLAT	4	REPLACES P/N 0042408000
43	020108060	SELF-LOCKING NUT.....	4	REPLACES P/N 0207008000
44	8943690210	GASKET	1	REPLACES P/N 0602320101
45	0207108000	SELF-LOCKING NUT	3	
46	M2334300304	COVER, EXHAUST PIPE	1	
46A	011008020	HEX. HEAD BOLT	2	REPLACES P/N 0016908020
47	Y0602326066	U-BOLT	2	

MUFFLER 2 ASSY.

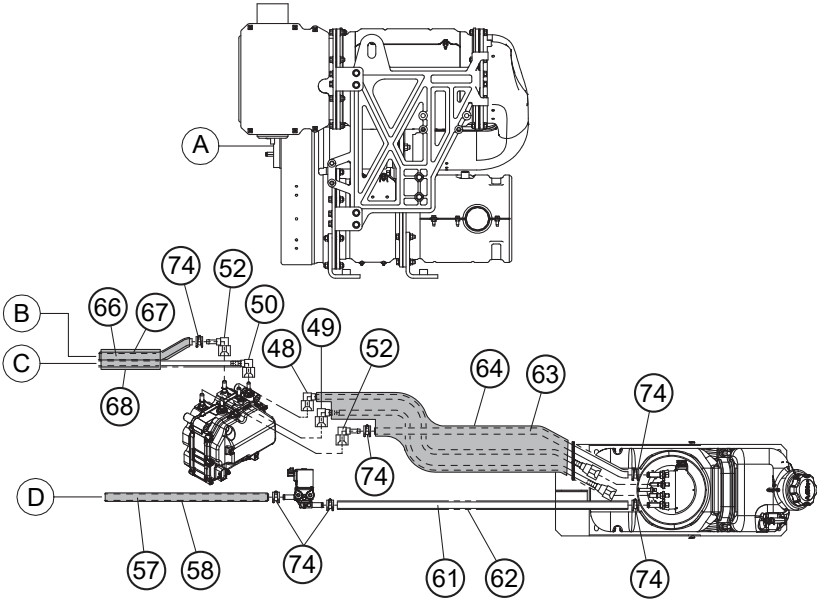
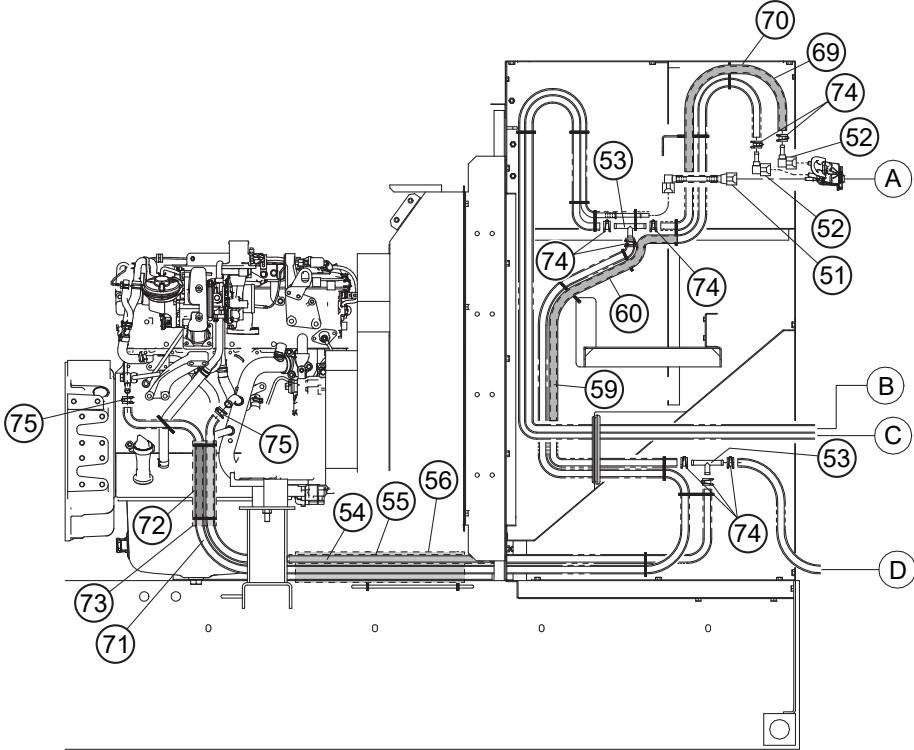

MUFFLER 2 ASSY.

<u>NO.</u>	<u>PART NO.</u>	<u>PART NAME</u>	<u>QTY.</u>	<u>REMARKS</u>
48	Y0602330461	DEF LINE	1	
49	Y0602330462	DEF LINE	1	
50	Y0602330463	DEF LINE	1	
51	Y0378900165	AEROFLEX TUBE	1	
52	Y0602330453	90° ELBOW JOINT	4	
53	Y0602330454	T-CONNECTOR	2	
54	Y0377102210	SCR COOLANT LINE	1	
55	Y0378501830	AEROFLEX TUBE	2	
56	Y0378500330	AEROFLEX TUBE	1	
57	Y0377100200	SCR COOLANT LINE	1	
58	Y0378501450	AEROFLEX TUBE	1	
59	Y0377101500	SCR COOLANT LINE	1	
60	Y0378501450	AEROFLEX TUBE	1	
61	Y0377100300	SCR COOLANT LINE	1	
62	Y0378500250	AEROFLEX TUBE	1	
63	Y0377100500	SCR COOLANT LINE	1	
64	Y0378700520	AEROFLEX TUBE	1	
66	Y0377101630	SCR COOLANT LINE	1	
67	Y0377701850	AEROFLEX TUBE	1	
68	Y0378500090	AEROFLEX TUBE	1	
69	Y0377100600	SCR COOLANT LINE	1	
70	Y0378500550	AEROFLEX TUBE	1	
71	Y0377103140	SCR COOLANT LINE	1	
72	Y0378501830	AEROFLEX TUBE	1	
73	Y0378501260	AEROFLEX TUBE	1	
74	Y0605515341	HOSE BAND	14	
75	Y0605515198	HOSE BAND	2	

FUEL TANK ASSY.

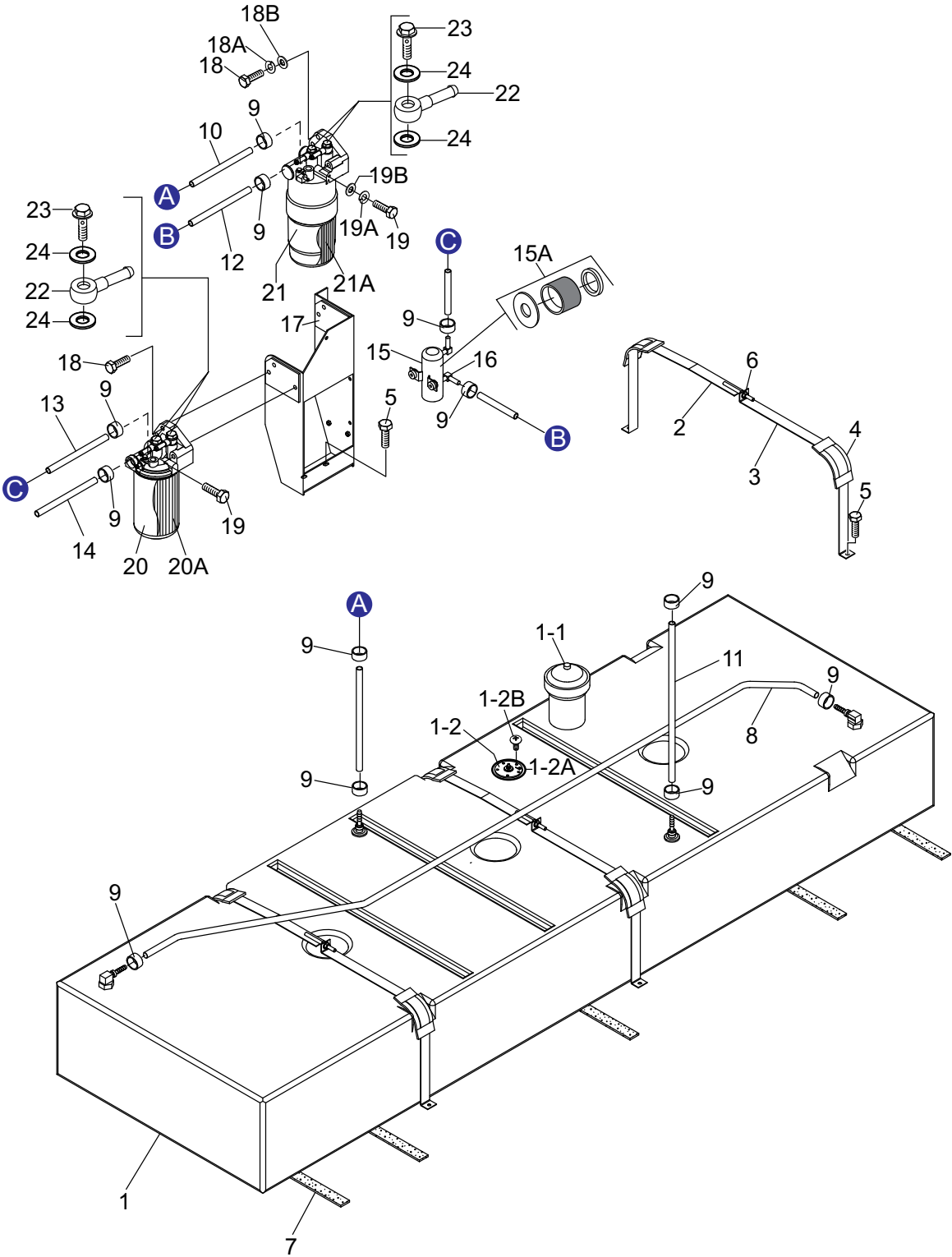

FUEL TANK ASSY.

<u>NO.</u>	<u>PART NO.</u>	<u>PART NAME</u>	<u>QTY.</u>	<u>REMARKS</u>
1	M2363001202	FUEL TANK	1	INCLUDES ITEMS W/#
1-1#	0605505070	FUEL TANK CAP	1	
1-2#	0605501079	FUEL SENDER UNIT	1	
1-2A#	0605516090	GASKET	1	
1-2B#	7538070	MACHINE SCREW	5	REPLACES P/N 0027104016
2	M2363200704	TANK BAND	3	
3	M2363200804	TANK BAND	3	
4	M9310500104	SUPPORTER SHEET	6	
5	011008020	HEX. HEAD BOLT	10	REPLACES P/N 0016908020
6	020108060	SELF-LOCKING NUT.....	6	REPLACES P/N 0207008000
7	0222100710	TANK SHEET	5	
8	0191302200	VENT HOSE	1	
9	Y0605515340	HOSE BAND	12	
10	0191300760	SUCTION HOSE	1	
11	0191300350	RETURN HOSE	1	
12	0191301160	SUCTION HOSE	1	
13	0191301000	SUCTION HOSE	1	
14	Y0191301450	SUCTION HOSE	1	
15	8980682750	FUEL FEED PUMP	1	REPLACES P/N 0602023240
15A	8980714010	FUEL FEED PUMP FILTER	1	
16	011606025	HEX. HEAD BOLT	2	REPLACES P/N 0016906025
17	M2364300103	BRACKET, FUEL FILTER	1	
18	0010110045	HEX. HEAD BOLT	4	
18A	0040010000	WASHER, LOCK	4	
18B	031110160	WASHER, FLAT	4	REPLACES P/N 0041210000
19	0010110080	HEX. HEAD BOLT	2	
19A	0040010000	WASHER, LOCK	2	
19B	031110160	WASHER, FLAT	2	REPLACES P/N 0041210000
20	8983129150	FUEL FILTER, MAIN	1	REPLACES P/N Y0602042416
20A	8983129180	FUEL FILTER ELEMENT, MAIN	1	
21	8980758553	FUEL FILTER, PRE.....	1	REPLACES P/N 0602042405
21A	8980742881	FUEL FILTER ELEMENT, PRE	1	
22	8973834270	JOINT PIPE.....	4	REPLACES P/N 0602042661
23	1096750951	EYE BOLT	4	
24	1096300860	PACKING	8	

ENCLOSURE ASSY.

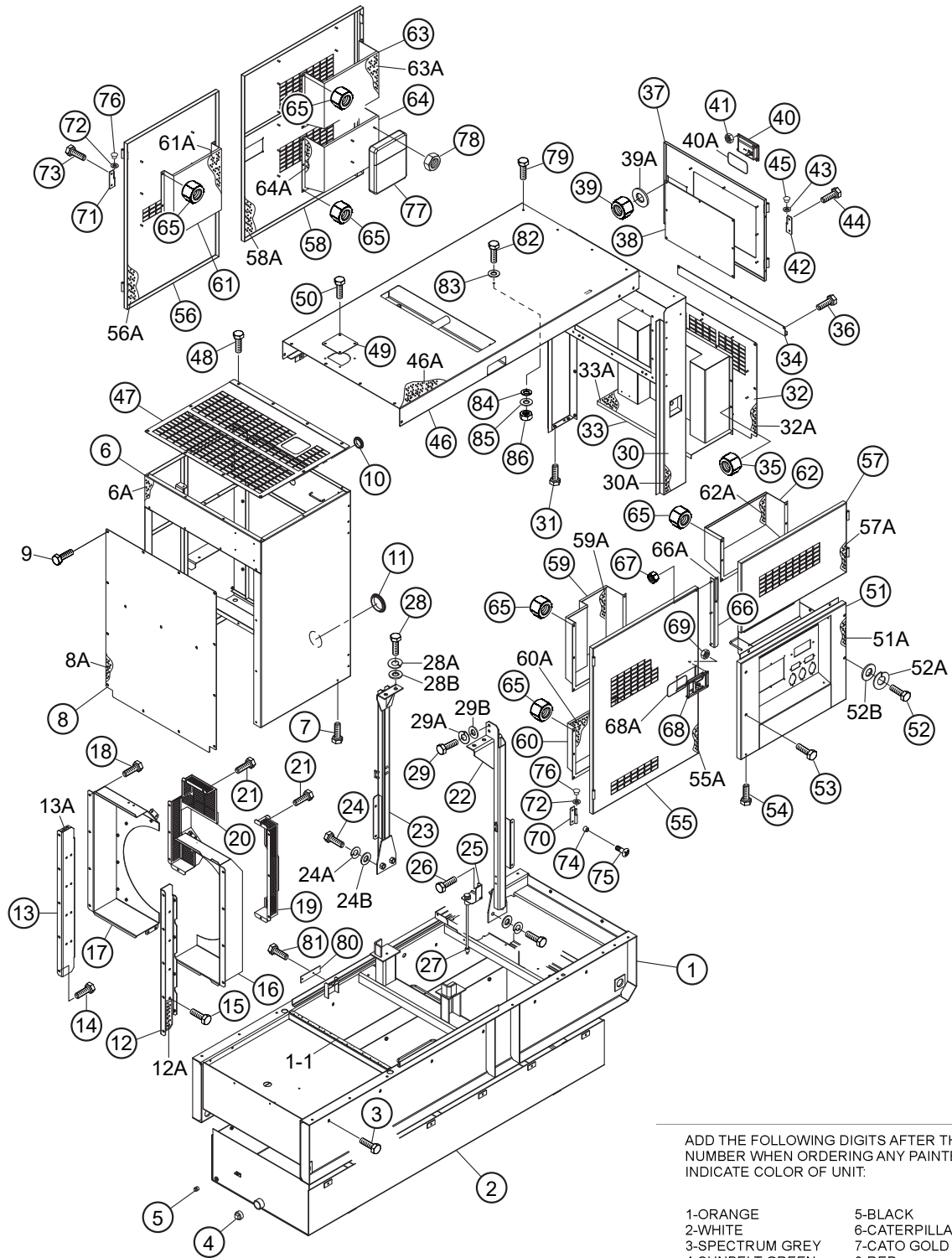

ADD THE FOLLOWING DIGITS AFTER THE PART NUMBER WHEN ORDERING ANY PAINTED PANEL TO INDICATE COLOR OF UNIT:

- | | |
|-----------------|----------------------|
| 1-ORANGE | 5-BLACK |
| 2-WHITE | 6-CATERPILLAR YELLOW |
| 3-SPECTRUM GREY | 7-CATO GOLD |
| 4-SUNBELT GREEN | 8-RED |

THE SERIAL NUMBER MAY BE REQUIRED.

ENCLOSURE ASSY.

<u>NO.</u>	<u>PART NO.</u>	<u>PART NAME</u>	<u>QTY.</u>	<u>REMARKS</u>
1	M2414000302	BASE	1	
1-1	Y0229200800	RUBBER SEAL	1	
2	M2364300303	ENVIRONMENTAL TANK	1	
3	0016910030	HEX. HEAD BOLT	12	
4	0603306797	SQUARE HEAD PIPE PLUG, 1-1/2"	1	
5	Y0603306793	SQUARE HEAD PIPE PLUG, 1/2"	1	S/N 7354617 AND BELOW
6	M2424000202	FRONT FRAME	1	S/N 7353751 AND BELOW
6	M2424000212	FRONT FRAME	1	S/N 7353752 AND ABOVE
6A	M2494102203	ACOUSTIC SHEET	1	
7	011008020	HEX. HEAD BOLT	6	REPLACES P/N 0016908020
8	M2424100204	COVER, FRONT FRAME	1	
8A	M2491200004	ACOUSTIC SHEET	1	
9	0019208020	HEX. HEAD BOLT	15	
10	0601851736	GROMMET	1	
11	Y0601851765	GROMMET	1	
12	M2311200204	RADIATOR BRACKET	1	
12A	M2491200104	ACOUSTIC SHEET	1	
13	M2311200304	RADIATOR BRACKET	1	
13A	M2491200104	ACOUSTIC SHEET	1	
14	011008020	HEX. HEAD BOLT	10	REPLACES P/N 0016908020
15	Y0016908015	HEX. HEAD BOLT	16	
16	M2311300803	FAN SHROUD	1	
17	M2311300903	FAN SHROUD	1	
18	011008020	HEX. HEAD BOLT	12	REPLACES P/N 0016908020
19	M2311301003	FAN GUARD	1	
20	M2311301103	FAN GUARD	1	
21	011008020	HEX. HEAD BOLT	11	REPLACES P/N 0016908020
22	M2434000303	HANGER	1	
23	M2434000403	HANGER	1	
24	Y0013620040	HEX. HEAD BOLT	4	
24A	030220510	WASHER, LOCK	4	REPLACES P/N 0040020000
24B	0041220000	WASHER, FLAT	4	
25	M2414800104	FUEL LEAK SWITCH BRACKET	1	
26	011008020	HEX. HEAD BOLT	2	REPLACES P/N 0016908020
27	0605503062	FUEL LEAK DETECTED SWITCH	1	
28	Y0013616035	HEX. HEAD BOLT	4	
28A	0041216000	WASHER, LOCK	4	
28B	0040016000	WASHER, FLAT	4	
29	Y0013612035	HEX. HEAD BOLT	2	
29A	031112230	WASHER, LOCK	2	REPLACES P/N 0041212000
29B	0040012000	WASHER, FLAT	2	
30	M2444000202	REAR FRAME	1	S/N 7356622 AND BELOW
30	M2444000212	REAR FRAME	1	S/N 7356623 AND ABOVE
30A	M2494301204	ACOUSTIC SHEET	1	S/N 7356622 AND BELOW
30A	M2494302604	ACOUSTIC SHEET	1	S/N 7356623 AND ABOVE

ENCLOSURE ASSY. (CONT'D.)

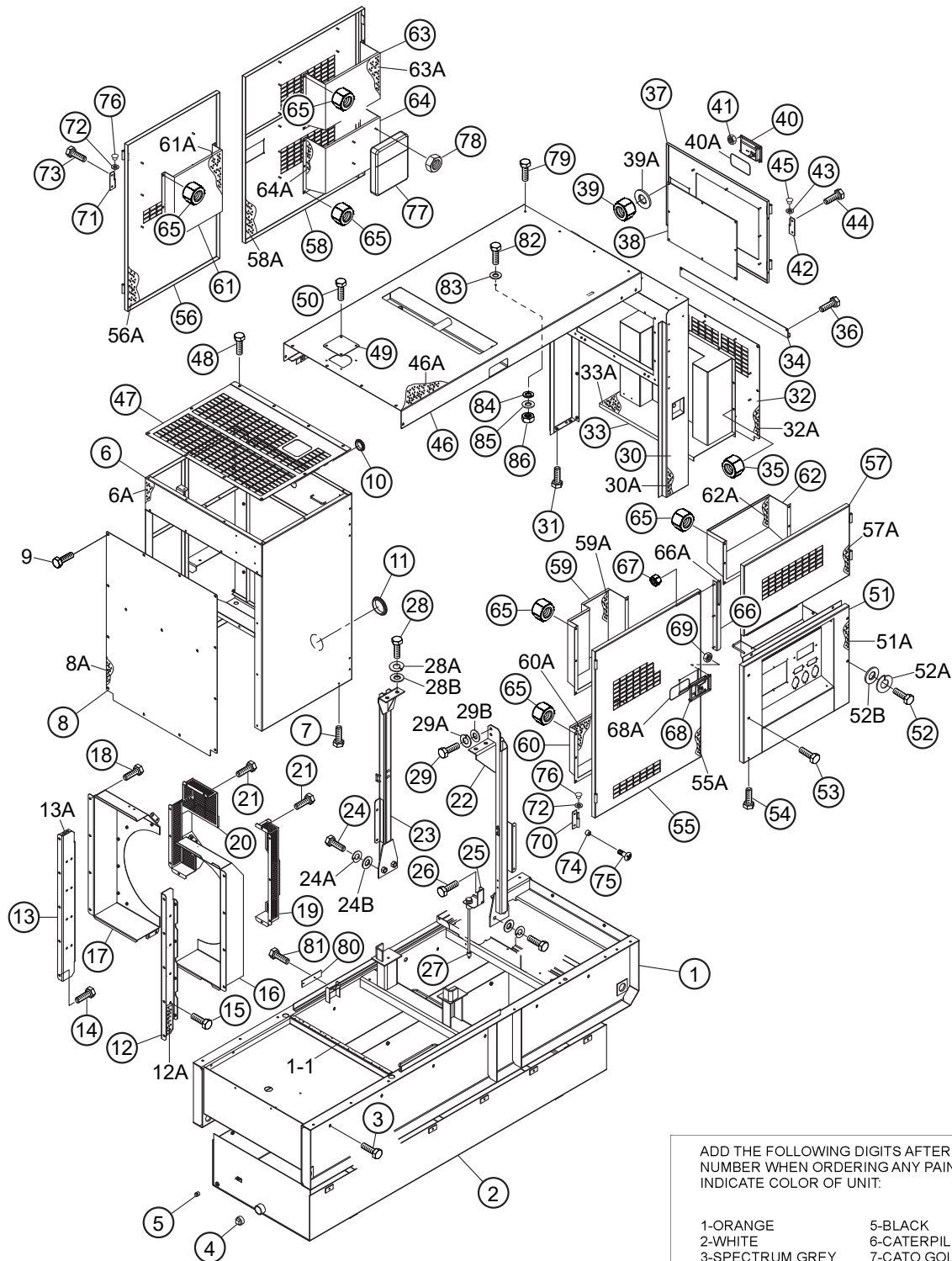

ADD THE FOLLOWING DIGITS AFTER THE PART NUMBER WHEN ORDERING ANY PAINTED PANEL TO INDICATE COLOR OF UNIT.

- | | |
|-----------------|----------------------|
| 1-ORANGE | 5-BLACK |
| 2-WHITE | 6-CATERPILLAR YELLOW |
| 3-SPECTRUM GREY | 7-CATO GOLD |
| 4-SUNBELT GREEN | 8-RED |

THE SERIAL NUMBER MAY BE REQUIRED.

ENCLOSURE ASSY. (CONT'D.)

NO.	PART NO.	PART NAME	QTY.	REMARKS
31	011008020	HEX. HEAD BOLT	4	REPLACES P/N 0016908020
32	M2444100004	REAR COVER	1	
32A	M2494300804	ACOUSTIC SHEET	1	
33	M2444300203	DUCT, REAR COVER	1	
33A	M2491400003	ACOUSTIC SHEET	1	
34	M2444800004	RAIN GUTTER	1	
35	0176060030	SELF-LOCKING NUT.....	10	REPLACES P/N 0207006000
36	0019208020	HEX. HEAD BOLT	9	
37	M2444200203	REAR DOOR	1	
38	M4443600004	WINDOW PLATE	1	
39	020106050	LOCK NUT	8	REPLACES P/N 0037906000
39A	952404470	WASHER, FLAT	8	REPLACES P/N 0041206000
40	Y0605012309	DOOR HANDLE	1	S/N 7355267 AND BELOW
40	Y0605012318	DOOR HANDLE	1	S/N 7355268 AND ABOVE
40A	C9312500004	SEAL RUBBER	1	
41	0176060030	HEX. NUT.....	4	REPLACES P/N 0207006000
42	M9110100204	HINGE	2	
43	M9116100004	WASHER	2	
44	0019208020	HEX. HEAD BOLT	3	
45	0845031504	BLIND PLUG	1	REPLACES P/N M9310000004
46	M2464000102	ROOF PANEL	1	
46A	M2494500803	ACOUSTIC SHEET	1	
47	M2424100404	OVER COVER, FRONT FRAME.....	1	S/N 7353751 AND BELOW
47	M2424100414	OVER COVER, FRONT FRAME.....	1	S/N 7353752 AND ABOVE
48	0019208020	HEX. HEAD BOLT	10	
49	M3310600004	COVER	1	
50	0019208020	HEX. HEAD BOLT	4	
51	M2454200202	SPLASHER PANEL.....	1	S/N 7354617 AND BELOW
51	M2454200502	SPLASHER PANEL.....	1	S/N 7354618 AND ABOVE
51A	M2494404604	ACOUSTIC SHEET	1	S/N 7354617 AND BELOW
51A	M2494409504	ACOUSTIC SHEET	1	S/N 7354618 AND ABOVE
52	0019108055	HEX. HEAD BOLT	2	
52A	0042308000	WASHER, LOCK	2	
52B	0401450080	WASHER, FLAT	2	REPLACES P/N 0042408000
53	0019208020	HEX. HEAD BOLT	2	
54	011008020	HEX. HEAD BOLT	3	REPLACES P/N 0016908020
55	M2454000803	SIDE DOOR	1	
55A	M2494403804	ACOUSTIC SHEET	1	
56	M2454000903	SIDE DOOR	1	
56A	M2494403904	ACOUSTIC SHEET	1	
57	M2454001003	SIDE DOOR	1	
57A	M2494404004	ACOUSTIC SHEET	1	
58	M2454001103	SIDE DOOR	1	
58A	M2494404104	ACOUSTIC SHEET	1	
59	M2454300504	DUCT	1	
59A	M2494404204	ACOUSTIC SHEET	1	

ENCLOSURE ASSY. (CONT'D.)

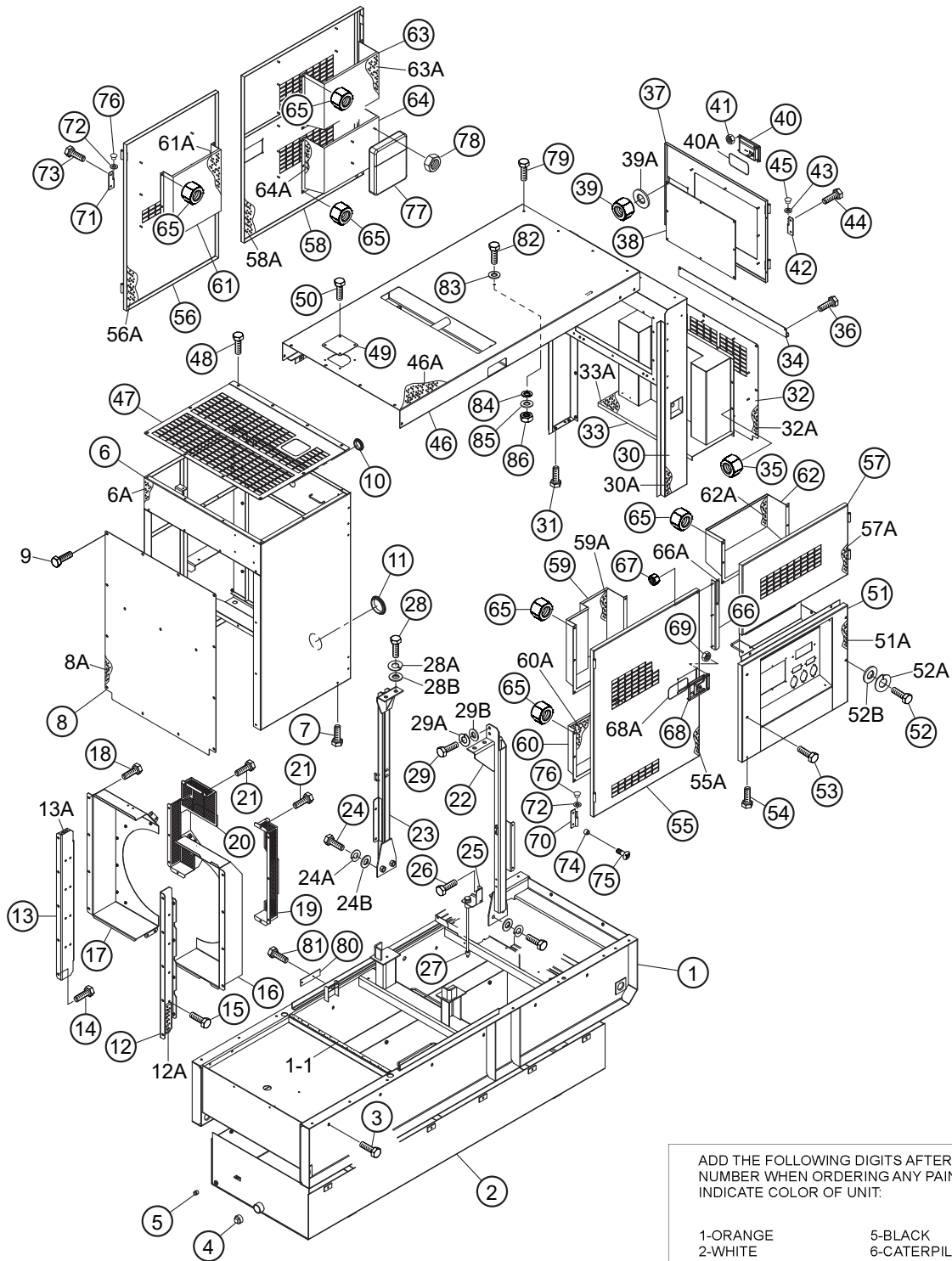

ADD THE FOLLOWING DIGITS AFTER THE PART NUMBER WHEN ORDERING ANY PAINTED PANEL TO INDICATE COLOR OF UNIT.

- | | |
|-----------------|----------------------|
| 1-ORANGE | 5-BLACK |
| 2-WHITE | 6-CATERPILLAR YELLOW |
| 3-SPECTRUM GREY | 7-CATO GOLD |
| 4-SUNBELT GREEN | 8-RED |

THE SERIAL NUMBER MAY BE REQUIRED.

ENCLOSURE ASSY. (CONT'D.)

<u>NO.</u>	<u>PART NO.</u>	<u>PART NAME</u>	<u>QTY.</u>	<u>REMARKS</u>
60	M2454300604	DUCT	1	
60A	M2494404304	ACOUSTIC SHEET	1	
61	M2454300704	DUCT	1	
61A	M2494404404	ACOUSTIC SHEET	1	
62	M2454301004	DUCT	1	
62A	M2494404804	ACOUSTIC SHEET	1	
63	M2454300904	DUCT	1	
63A	M2494404704	ACOUSTIC SHEET	1	
64	M2454300804	DUCT	1	
64A	M2494404504	ACOUSTIC SHEET	1	
65	0176060030	SELF-LOCKING NUT.....	42	REPLACES P/N 0207006000
66	M2454700604	DOOR SUPPORTER	1	
66A	0229200460	RUBBER SEAL	1	
67	0176060030	SELF-LOCKING NUT.....	3	REPLACES P/N 0207006000
68	Y0605012309	DOOR HANDLE.....	3	S/N 7355267 AND BELOW
68	Y0605012318	DOOR HANDLE.....	3	S/N 7355268 AND ABOVE
68A	C9312500004	SEAL RUBBER	3	
69	0176060030	HEX. NUT.....	12	REPLACES P/N 0207006000
70	M9110100204	HINGE	4	
71	M9110100304	HINGE	4	
72	M9116100004	WASHER	7	
73	0019208020	HEX. HEAD BOLT	9	
74	0601850097	DOOR STOPPER	8	
75	0027208025	MACHINE SCREW	7	
76	0845031504	BLIND PLUG.....	7	REPLACES P/N M9310000004
77	0600800320	MANUAL PAK	1	
78	0176060030	HEX. NUT.....	4	REPLACES P/N 0207006000
79	0019208020	HEX. HEAD BOLT	10	
80	M2414800304	HOLE COVER.....	1	S/N 7354458 AND ABOVE
81	011008020	HEX. HEAD BOLT.....	2	REPLACES P/N 0016908020 S/N 7354458 AND ABOVE
82	0019112030	HEX. HEAD BOLT.....	1	S/N 7356383 AND ABOVE
83	Y0605050040	SEALING WASHER.....	1	S/N 7356383 AND ABOVE
84	0042312000	WASHER, LOCK.....	1	S/N 7356383 AND ABOVE
85	0042412000	WASHER, FLAT.....	1	S/N 7356383 AND ABOVE
86	0030012000	HEX. HEAD NUT.....	1	S/N 7356383 AND ABOVE

RUBBER SEALS ASSY.

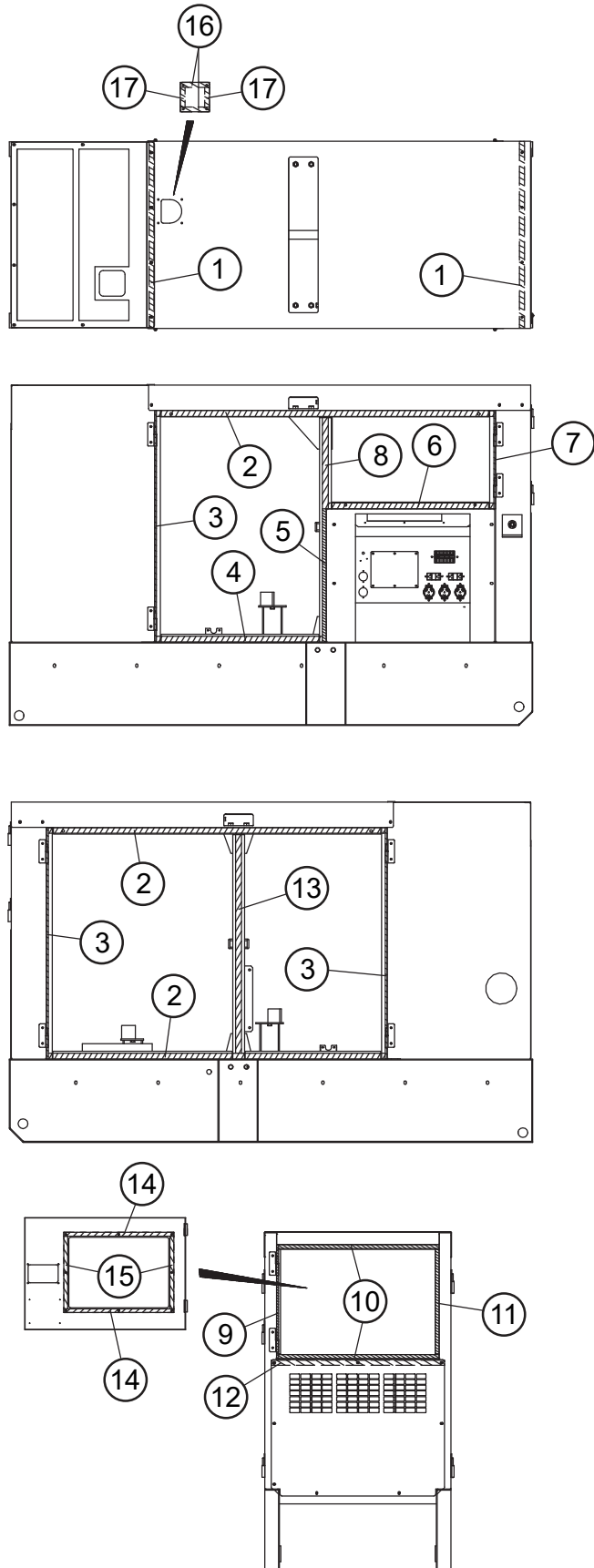

RUBBER SEALS ASSY.

<u>NO.</u>	<u>PART NO.</u>	<u>PART NAME</u>	<u>QTY.</u>	<u>REMARKS</u>
1	0229200950	RUBBER SEAL	2	
2	Y0228901720	RUBBER SEAL	3	
3	Y0229401180	RUBBER SEAL	3	
4	0228900850	RUBBER SEAL	1	
5	Y0228800680	RUBBER SEAL	1	
6	Y0228900845	RUBBER SEAL	1	
7	Y0229400500	RUBBER SEAL	1	
8	0228900470	RUBBER SEAL	1	
9	0228800580	RUBBER SEAL	1	
10	Y0228800820	RUBBER SEAL	2	
11	0228800540	RUBBER SEAL	1	
12	Y0229200885	RUBBER SEAL	1	
13	0228901120	RUBBER SEAL	1	
14	0228100560	RUBBER SEAL	2	
15	0228100370	RUBBER SEAL	2	
16	Y0229200145	RUBBER SEAL	2	
17	Y0229200100	RUBBER SEAL	2	

BATTERY CHARGER ASSY. (OPTION)

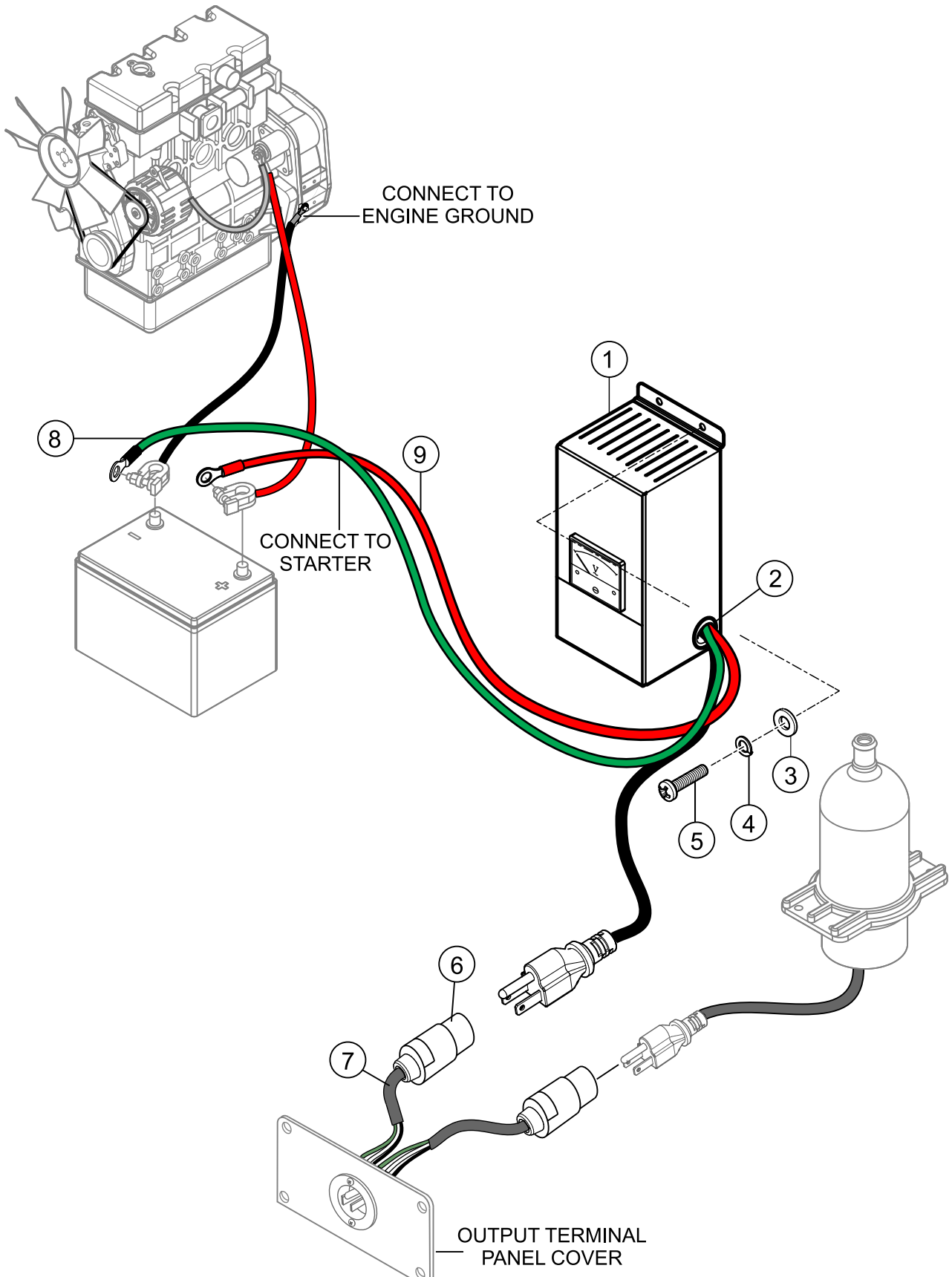

BATTERY CHARGER ASSY. (OPTION)

<u>NO.</u>	<u>PART NO.</u>	<u>PART NAME</u>	<u>QTY.</u>	<u>REMARKS</u>
1	LC125002	CHARGER BATTERY, 3 AMP 12V	1	
2		GROMMENT, 7/8" HOLE SIZE	1	OBTAIN LOCALLY
3		WASHER, FLAT M4	4	OBTAIN LOCALL
4		WASHER, LOCK M4.....	4	OBTAIN LOCALLY
5		SCREW, M4X10	4	OBTAIN LOCALLY
6	HBL5369C	CONNECTOR, 20 AMP ,125V	1	
7	EE56557	CORD, 3-CONDUCTOR, 14 AWG	6 FT.....	1PC=1FT
8		WIRE, 16GA, GREEN.....	9 FT.....	OBTAIN LOCALLY
9		WIRE, 16GA, RED	9 FT.....	OBTAIN LOCALLY

JACKET WATER HEATER ASSY. (OPTION)

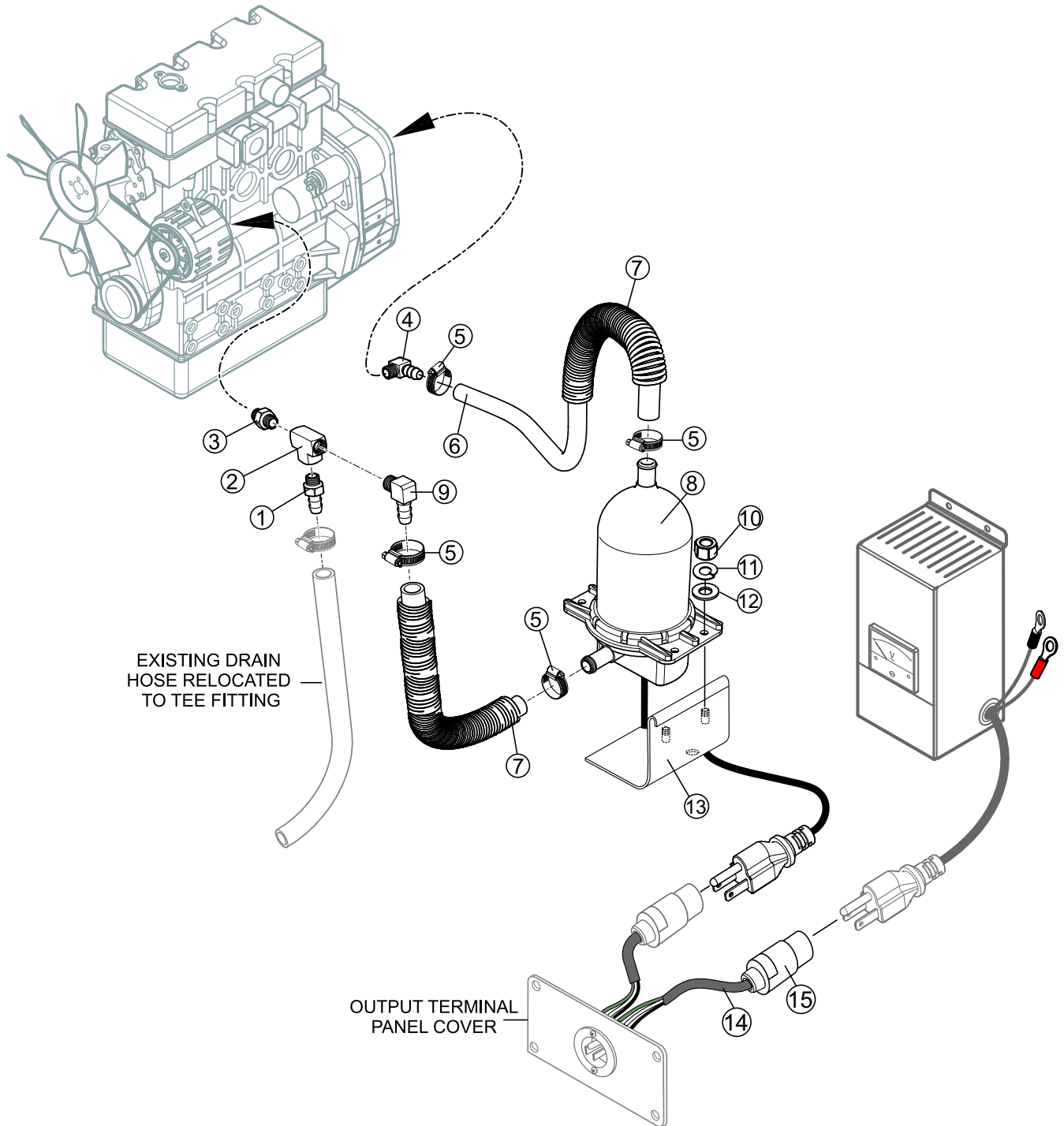

JACKET WATER HEATER ASSY. (OPTION)

<u>NO.</u>	<u>PART NO.</u>	<u>PART NAME</u>	<u>QTY.</u>	<u>REMARKS</u>
1		1/4" MP X 5/16 HB NIPPLE	1.....	OBTAIN LOCALLY
2		1/4 X 1/4 1/4" FEMALE PIPE TEE.....	1.....	OBTAIN LOCALLY
3		1/4 X 1/4 MALE TO MALE PIPE NIPPLE	1.....	OBTAIN LOCALLY
4		3/8" MP X 5/8 HB 90° ELBOW.....	1.....	OBTAIN LOCALLY
5		HOSE CLAMP #10	4.....	OBTAIN LOCALLY
6		HEATER HOSE, 5/8" ID X 30" LONG.....	1.....	OBTAIN LOCALLY
7		SPLIT LOOM, 1 " X 20"	2.....	OBTAIN LOCALLY
8	TPS101GT10000	HEATER, 1000W, 120 VAC	1	
9		1/4 X 1/4 5/8" HB 90° ELBOW	1.....	OBTAIN LOCALLY
10		NUT, 1/4"	4.....	OBTAIN LOCALLY
11		WASHER, LOCK 1/4"	6.....	OBTAIN LOCALLY
12		WASHER, FLAT 1".....	4.....	OBTAIN LOCALLY
13	34410	BRACKET, HOT START	1	
14	EE56557	CORD, 3-CONDUCTOR, 14 AWG, 2 FT.	1	
15	HBL5369C	CONNECTOR, 20 AMP ,125V	1	

NAMEPLATE AND DECALS ASSY.

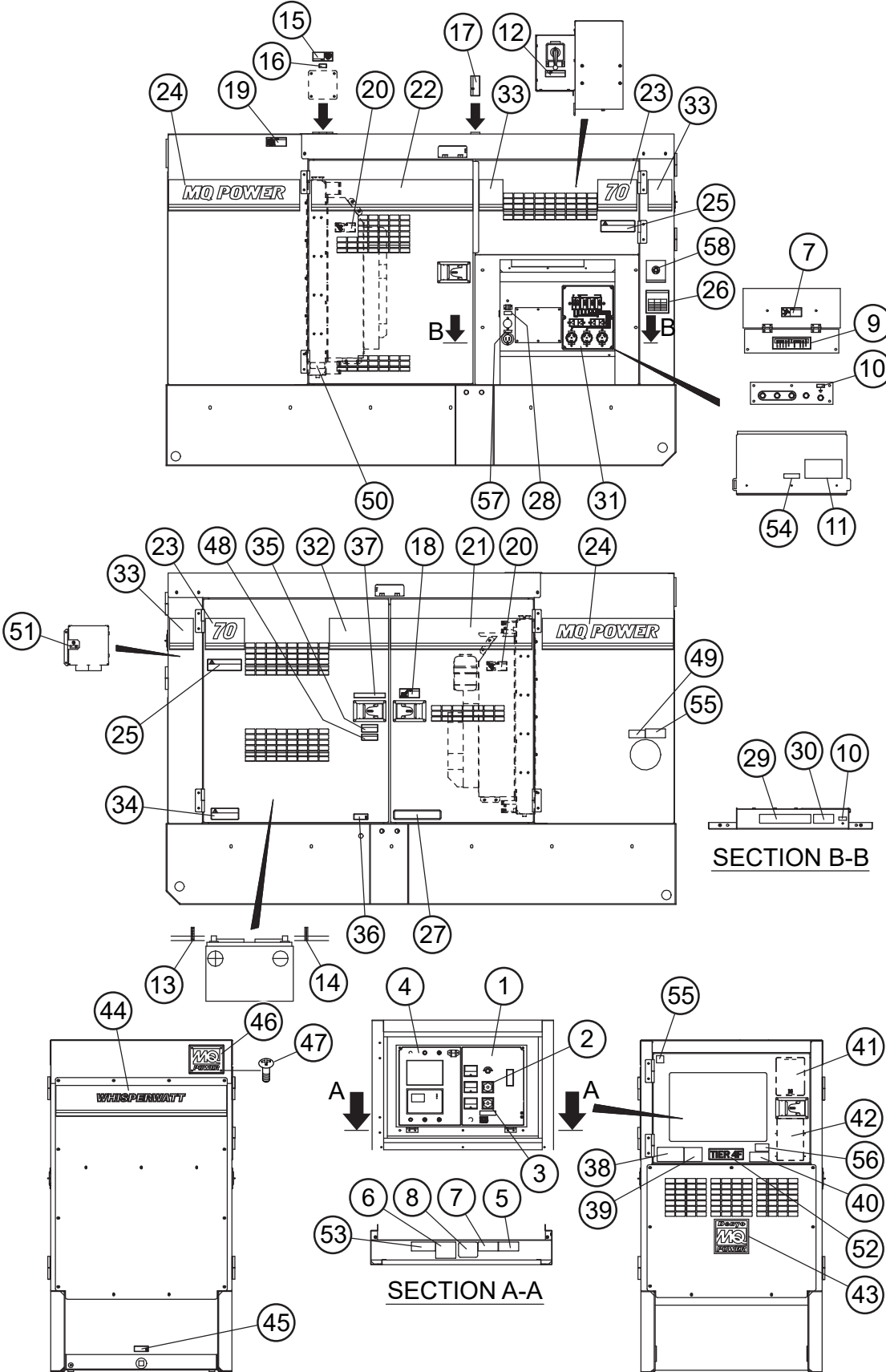

NAMEPLATE AND DECALS ASSY.

NO.	PART NO.	PART NAME	QTY.	REMARKS
1	M2551000503	DECAL: ENGINE OPERATION.....	1	M25100050
2	M9520000104	DECAL: AMMETER CHANGE-OVER SW...	1	M92000010
3	M9520000204	DECAL: VM CHANGE-OVER SW.....	1	M92000020
4	M2551000403	DECAL: GENERATOR CONTROL.....	1	M25100040
5	M9520100704	DECAL: WARNING ARC FLASH.....	1	M92010070
6	M9520100304	DECAL: GENERAL CAUTIONS.....	1	M92010030
7	M9520100004	DECAL: WARNING ELECT. SHOCK.....	2	M92010000
8	M9520200404	DECAL: O. C. R. RESET.....	1	M92020040
9	M9520200003	DECAL: CONNECT. OF OUTPUT CABLE..	1	M92020000
10	M9520000004	DECAL: GROUNDING.....	2	M92000000
11	M9520100404	DECAL: DANGER HIGH VOLTAGE.....	1	M92010040
12	M9520100204	DECAL: CAUTION CHANGE-OVER SW....	1	M92010020A
13	M9500300104	DECAL: +.....	1	M90030010
14	M9500300004	DECAL: -.....	1	M90030000
15	M9503100004	DECAL: WARNING RADIATOR CAP.....	1	M90310000
16	M9500100004	DECAL: WATER.....	1	M90010000
17	M1550001504	DECAL: CAUTION LIFTING CAPACITY....	1	M15000150
18	M9510100004	DECAL: CAUTION HIGH TEMP.....	1	M91010000
19	9503200004	DECAL: WARNING EXHAUST GAS.....	1	M90320000
20	M9503000004	DECAL: WARNING ROTATING PART.....	2	M90300000
21	M2561100903	STRIPE	1	
22	M2561100803	STRIPE	1	
23	M2561101104	STRIPE	1	
24	M2561100703	STRIPE	2	
25	M9520100603	DECAL: WARNING AUTO START.....	2	M92010060
26	M2550000304	DECAL: NOTE LOAD SHARING.....	1	M25000030A
27	M9503000103	DECAL: DAILY CHECK WATER AND OIL..	1	M90300010
28	M9520000504	DECAL: START CONTACT.....	1	M92000050
29	M9520100503	DECAL: WARNING.....	1	M92010050
30	M9511100104	DECAL: NOTE RECEPTACLE.....	1	M91110010
31	M1550000703	DECAL: AUXILIARY OUTPUT.....	1	M15000070
				S/N 7354617 AND BELOW
31	M3551002003	DECAL: AUXILIARY OUTPUT.....	1	M35100200
				S/N 7354618 AND ABOVE
32	M2561101904	STRIPE.....	1	REPLACES P/N M2561101203
33	M2561101004	STRIPE	3	
34	M9510100403	DECAL: WARNING BATTERY CONNECT..	1	M91010040A
35	M9501500004	DECAL: DIESEL FUEL.....	1	M90150000
36	M9500000004	DECAL: OIL DRAIN.....	1	M90000000
37	M9510000104	DECAL: DOCUMENT BOX LOCATED.....	1	M91000010
38	M9511100004	DECAL: WARNING ENV. TANK.....	1	M91110000
39	M9503200104	DECAL: DANGER EX. GAS (INDOOR)....	1	M90320010
40	920214100	DECAL: WARNING START FIRES.....	1	REPLACES P/N M9504200004
				M90420000
41	9501200003	DECAL: SCR PURGE SYSTEM.....	1	M90120000
42	M2551000303	OPERATING PROCEDURES.....	1	M25100030
				S/N 7356622 AND BELOW

NAMEPLATE AND DECALS ASSY. (CONT'D.)

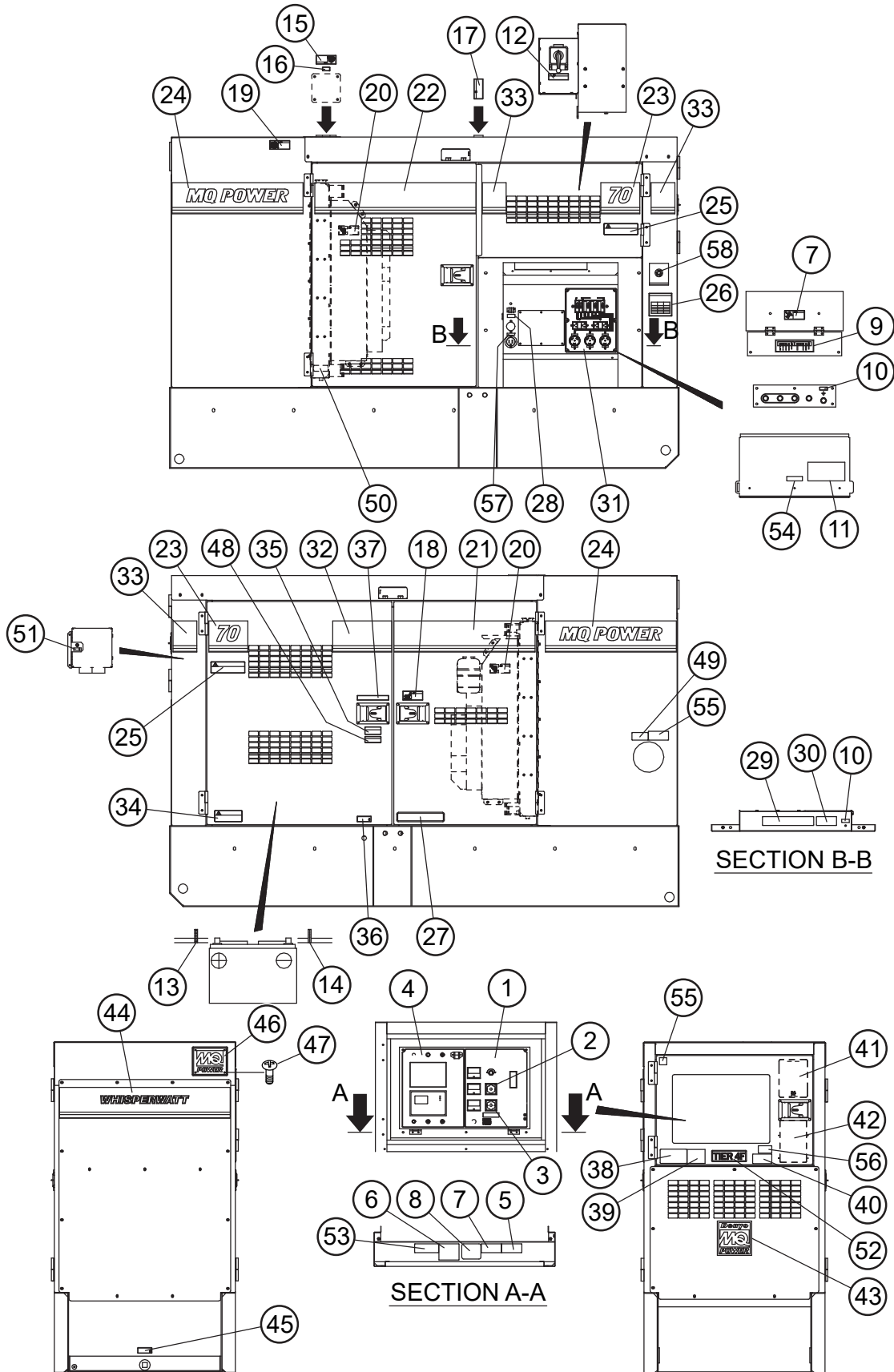

NAMEPLATE AND DECALS ASSY. (CONT'D.)

<u>NO.</u>	<u>PART NO.</u>	<u>PART NAME</u>	<u>QTY.</u>	<u>REMARKS</u>
42	M2551000803	OPERATING PROCEDURES	1	M25100080 S/N 7356623 AND ABOVE
43	M9511200204	STICKER, MQ	1	M91120020
44	2561100103	STRIPE	1	
45	M9510000004	DECAL: FLUID DRAIN	1	M91000000
46	0600500092	EMBLEM	1	
47	0021106015	MACHINE SCREW	4	
48	M9504500004	DECAL: REFILL DEF AS WELL.....	1	M90450000
49	M9501500104	DECAL: DIESEL EXHAUST FLUID.....	1	M90150010
50	M9500100304	DECAL: INTER-COOLER DRAIN	1	M90010030
51	M9520002104	DECAL: FUEL PUMP SWITCH.....	1	M92000210
52	M9511200103	DECAL: TIER 4F	1	M91120010
53	M9501300104	DECAL: CAUTION BATTERY CABLES	1	M90130010
54	M9521200604	DECAL: BONDED NEUTRAL	1	M92120060 S/N 7353347 AND ABOVE
55	M9541100004	DECAL: CAUTION EXH. FLUID ONLY.....	1	M94110000 S/N 7354148 AND ABOVE
56	M9504200104	DECAL: WARNING PROPOSITION 65.....	1	M90420010 S/N 7354848 AND ABOVE
57	M9522000004	DECAL: WATER HEATER	1	M92200000 S/N 7355078 AND ABOVE
58	M9521002804	DECAL: EMERGENCY STOP BUTTON	1	M92100280 S/N 7356623 AND ABOVE