

# OPERATION AND PARTS MANUAL

# STOW

A DIVISION OF MULTIQUIP INC.

## CUTTER 1

### MODEL CD613H18

(HONDA GX390 GASOLINE ENGINE)

### MODEL CD605E16

(5 HP ELECTRIC MOTOR)

## CONCRETE/ASPHALT SAW

Revision #6 (06/06/08)

THIS MANUAL MUST ACCOMPANY THE EQUIPMENT AT ALL TIMES.

P/N 25498

# STOW CUTTER 1 SAW — TABLE OF CONTENTS

Proposition 65 Warning .....	2
Table Of Contents .....	4
Parts Ordering Procedures .....	5
Safety Message Alert Symbols .....	6-7
Rules For Safe Operation .....	8-10
Specifications (Saw) .....	11
Specifications (Engine) .....	12

## STOW — CUTTER 1 SAW

Controls & Components .....	13
Basic Engine .....	14
Preparation/Pre-Inspection .....	15-17
Blades .....	18
Blade Placement .....	19
Initial Start-Up .....	20-21
Operation .....	21
Maintenance .....	22-23
Troubleshooting (Saw) .....	24
Troubleshooting (Engine) .....	25-26
Explanation of Codes in Remarks Column .....	28
Suggested Spare Parts .....	29
Nameplate and Decals .....	30-31
Engine, Belts And Pulleys Assembly .....	32-33
Electric Motor Assembly .....	34-35
Undercarriage Assembly .....	36-37
Blade Assembly & Water System Assembly .....	38-39
Pointer Assembly .....	40-41

## HONDA GX390K1QWT2/ GX390U1QWT2 ENGINES

Air Cleaner Assembly .....	42-43
Camshaft Assembly .....	44-45
Carburetor Assembly .....	46-47
Control Assembly .....	48-49
Crankcase Cover Assembly .....	50-51
Crankshaft Assembly .....	52-53
Cylinder Barrel Assembly .....	54-55
Cylinder Head Assembly .....	56-57
Fan Cover Assembly .....	58-59
Flywheel Assembly .....	60-61
Fuel Tank Assembly .....	62-63
Ignition Coil Assembly .....	64-65
Muffler Assembly .....	66-67
Piston Assembly .....	68-69
Recoil Starter Assembly .....	70-71
Labels .....	72-73

Terms and Conditions of Sale — Parts .....	74
--	----

# STOW CUTTER 1 SAW — SUGGESTED SPARE PARTS

## SUGGESTED SPARE PARTS

### STOW CUTTER 1 SAW CONCRETE/ASPHALT SAW

1 TO 3 UNITS WITH HONDA 13 HP GX390K1QWT2/GX390U1QWT2 ENGINES  
AND 5HP ELECTRIC MOTOR.

#### *1 to 3 Units*

Qty. ....	P/N .....	Description
3	20478 .....	HAND GRIP
4	2621 .....	GREASE ZERK, SPINDLE BEARING
4	1162 A .....	CAP, GREASE ZERK
3	13249 .....	BELT (3VX315) 13HP HONDA
3	16779-006 .....	BELT (3VX300) 5HP ELECTRIC MOTOR
3	9807956846 .....	SPARK PLUG, BPR6ES, NKG
1✖	17620ZH7023 .....	TANK CAP, BLACK, (S/N 3605677 AND BELOW)
1✖	17620Z0T305 .....	TANK CAP, CHROME PLATED, (S/N 3605678 AND ABOVE)
1◇	17620Z0T305 .....	TANK CAP, CHROME PLATED
2	17210ZE3010 .....	AIR CLEANER ELEMENT
1✖	28462ZV7003 .....	ROPE, RECOIL STARTER
1◇	28462ZE3W01 ....	ROPE, RECOIL STARTER
2	28086001 .....	8" REAR WHEEL ( GAS MODEL)
2	23668001 .....	6" REAR WHEEL ( ELECTRIC MODEL)
2	26221001 .....	4" FRONT WHEEL
1	29013001 .....	1-1/2" BOX WRENCH

# STOW CUTTER 1 SAW — NAMEPLATE AND DECALS

## DECALS

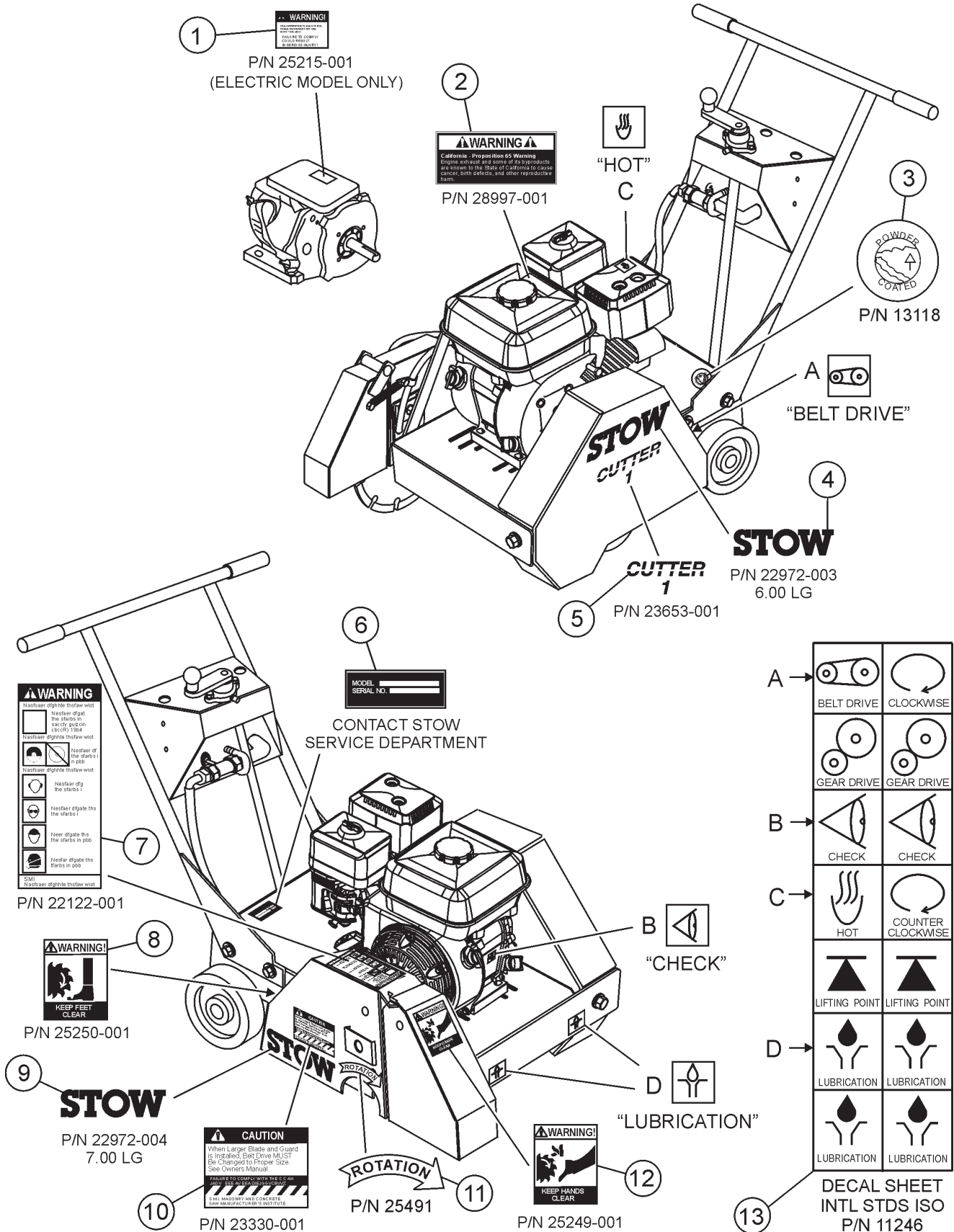

# STOW CUTTER 1 SAW — NAMEPLATE AND DECALS

## NAMEPLATE AND DECALS

<u>NO.</u>	<u>PART NO.</u>	<u>PART NAME</u>	<u>QTY.</u>	<u>REMARKS</u>
1	25215-001	DECAL, WARNING .....	1 .....	ELECTRIC MODEL ONLY
2	28997-001	DECAL, PROP 65 WARNING	1	
3	13118	DECAL, POWDER COATED	1	
4	22972-003	DECAL, STOW 6.00	1	
5	23653-001	DECAL, STOW CUTTER 1 SAW	1	
6		SERIAL NUMBER PLATE .....	1 .....	CONTACT PARTS DEPT.
7	22122-001	DECAL, WARNING	1	
8	25250-001	DECAL, WARNING FEET	1	
9	22972-004	DECAL, STOW 7.00	1	
10	23330-001	DECAL, CAUTION BLADE GUARD	1	
11	25491	DECAL, ROTATION	1	
12	25249-001	DECAL, WARNING HANDS	1	
13	11246	DECAL SHEET, INTL STDS.	1	

# STOW CUTTER 1 SAW — ENGINE, BELTS AND PULLEYS ASSY.

ENGINE, BELTS AND PULLEYS ASSY.

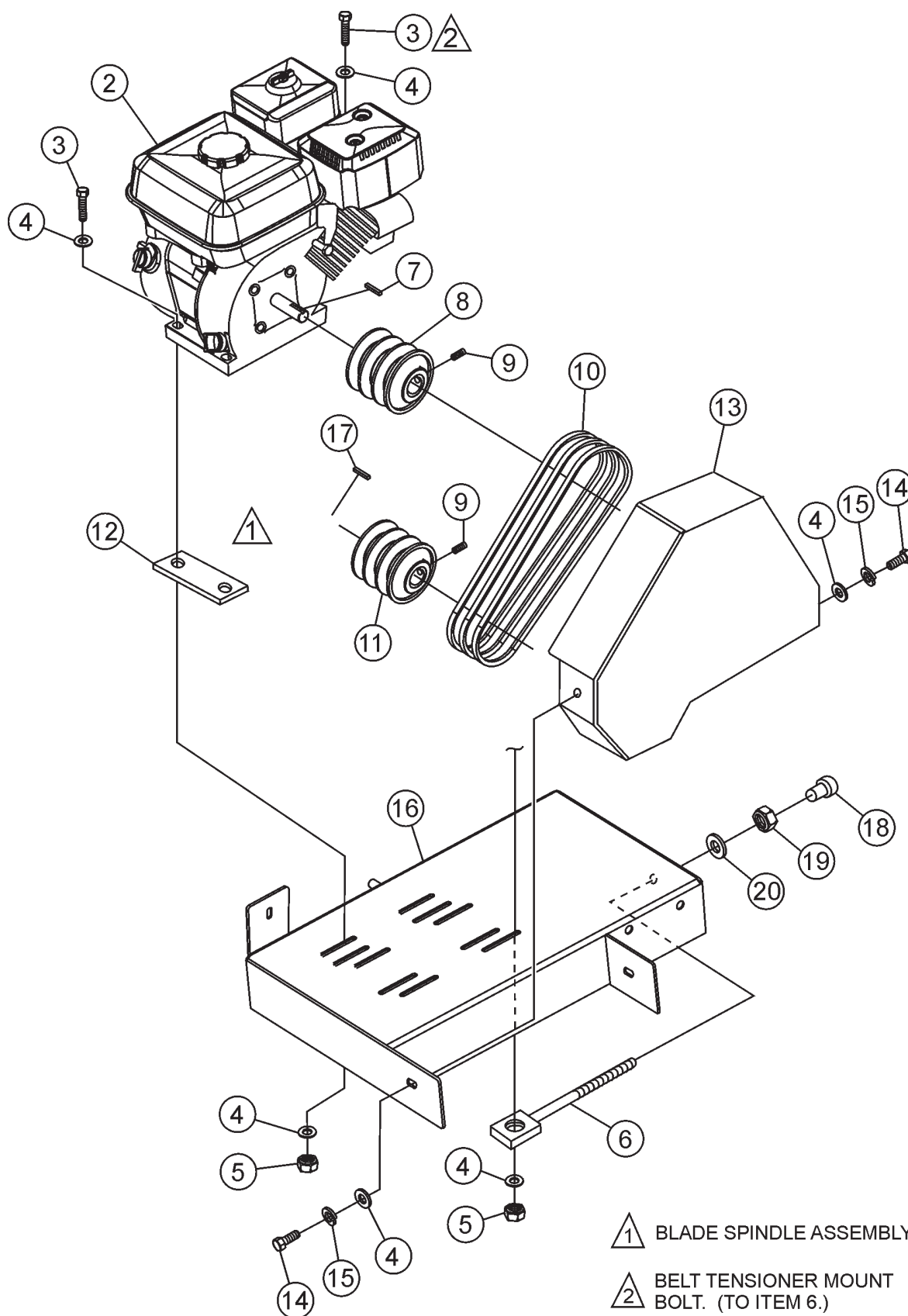

# STOW CUTTER 1 SAW — ENGINE, BELTS AND PULLEYS ASSY.

ENGINE, BELTS AND PULLEYS ASSY.

<u>NO.</u>	<u>PART NO.</u>	<u>PART NAME</u>	<u>QTY.</u>	<u>REMARKS</u>
2	15103	ENGINE 13 HP HONDA CYCLONE	1	
3	0669 A	SCREW. HHCS 5/16-18 x 2-1/4"	4	
4	0300 B	FLAT WASHER 5/16"	10	
5	5283	NUT, 5/16 - 18 LOCK	4	
6	23811-352	BELT TENSIONER	2	
7	6059 B	SQUARE KEY, 1/4 X 2	1	
8	23665-001	PULLEY, ENGINE	1	
9	25354	SCREW, SHS 1/4 - 20 X 1/2 ALLOY	4	
10	13249	BELT, 3VX315	3	
11	23665-009	PULLEY, SPINDLE	1	
12	27044-001	SPACER	2	
13	26105-351	BELT GUARD, 13HP	1	
14	0202	SCREW, 5/16 - 12 X 1	2	
15	161 C	WASHER, LOCK 5/16	2	
16	26112-354	FRAME	1	
17	9152	KEY, 1/4 X 1-3/4	1	
18	10779-011	CAP	2	
19	10133	NUT, 3/8 - 16	2	
20	10136	WASHER, FLAT 3/8	2	

# STOW CUTTER 1 SAW — ELECTRIC MOTOR ASSY.

ELECTRIC MOTOR ASSY.

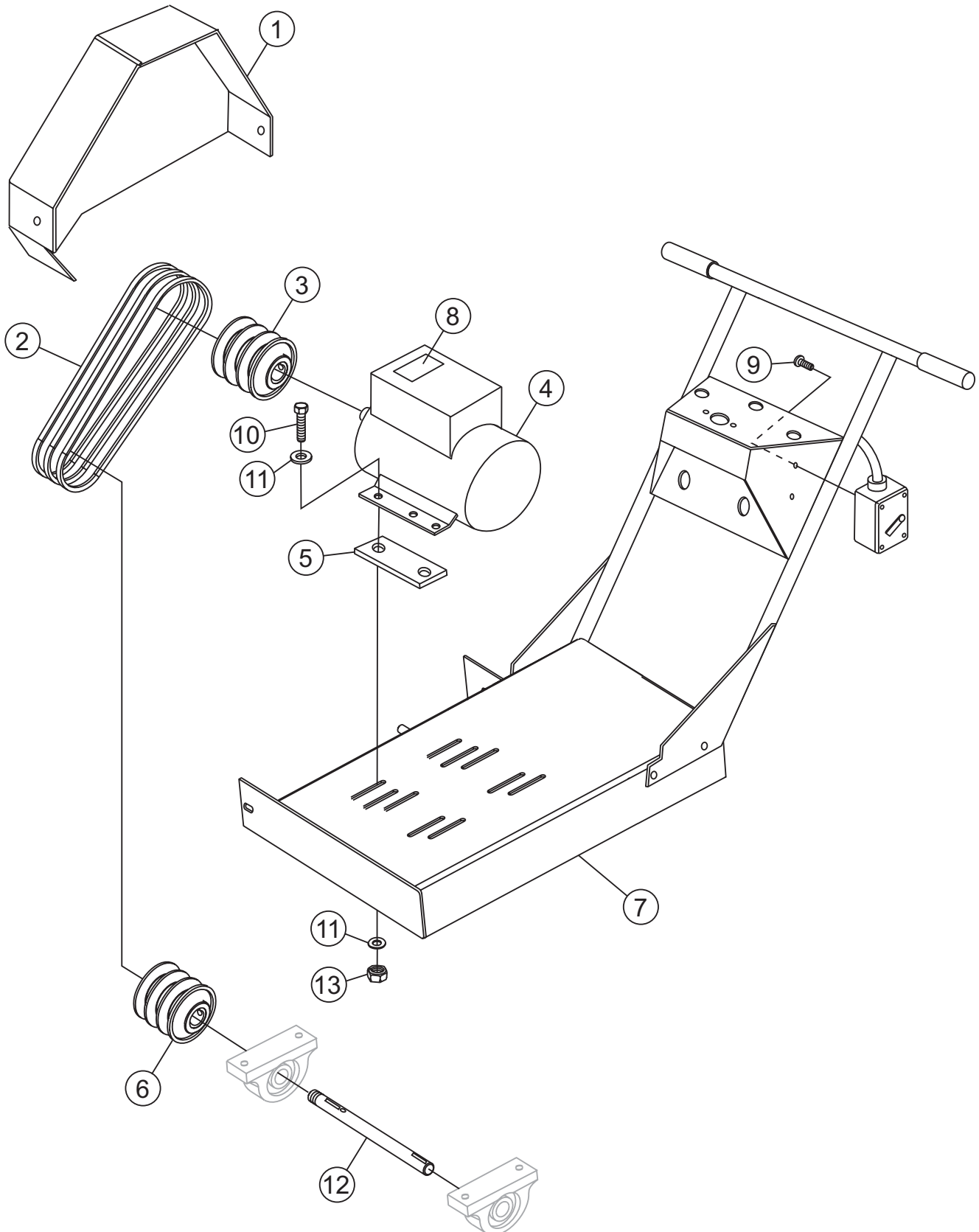



## STOW CUTTER 1 SAW — ELECTRIC MOTOR ASSY.

### ELECTRIC MOTOR ASSY.

<u>NO.</u>	<u>PART NO.</u>	<u>PART NAME</u>	<u>QTY.</u>	<u>REMARKS</u>
1	26142-352	BELT GUARD	1	
2	16779-006	BELT - 3VX300	3	
3	23665-005	PULLEY (MOTOR)	1	
4	26152-502	MOTOR, 5 HP ELECTRIC	1	
5	27084-002	SPACER	2	
6	23665-009	PULLEY (SPINDLE)	1	
7	26145-351	FRAME	1	
8	25215-001	LABEL, WARNING	1	
9	23865-001	SCREW, 10 - 24 X 3/4	2	
10	2623	SCREW, HHC 5/16 - 18 x 1-1/4"	4	
11	07030-005	FLAT WASHER 5/16	8	
12	26136-004	SPINDLE	1	
13	5283	NUT, 5/16 - 18 LOCK	4	

# STOW CUTTER 1 SAW — UNDERCARRIAGE ASSY.

## UNDERCARRIAGE ASSY

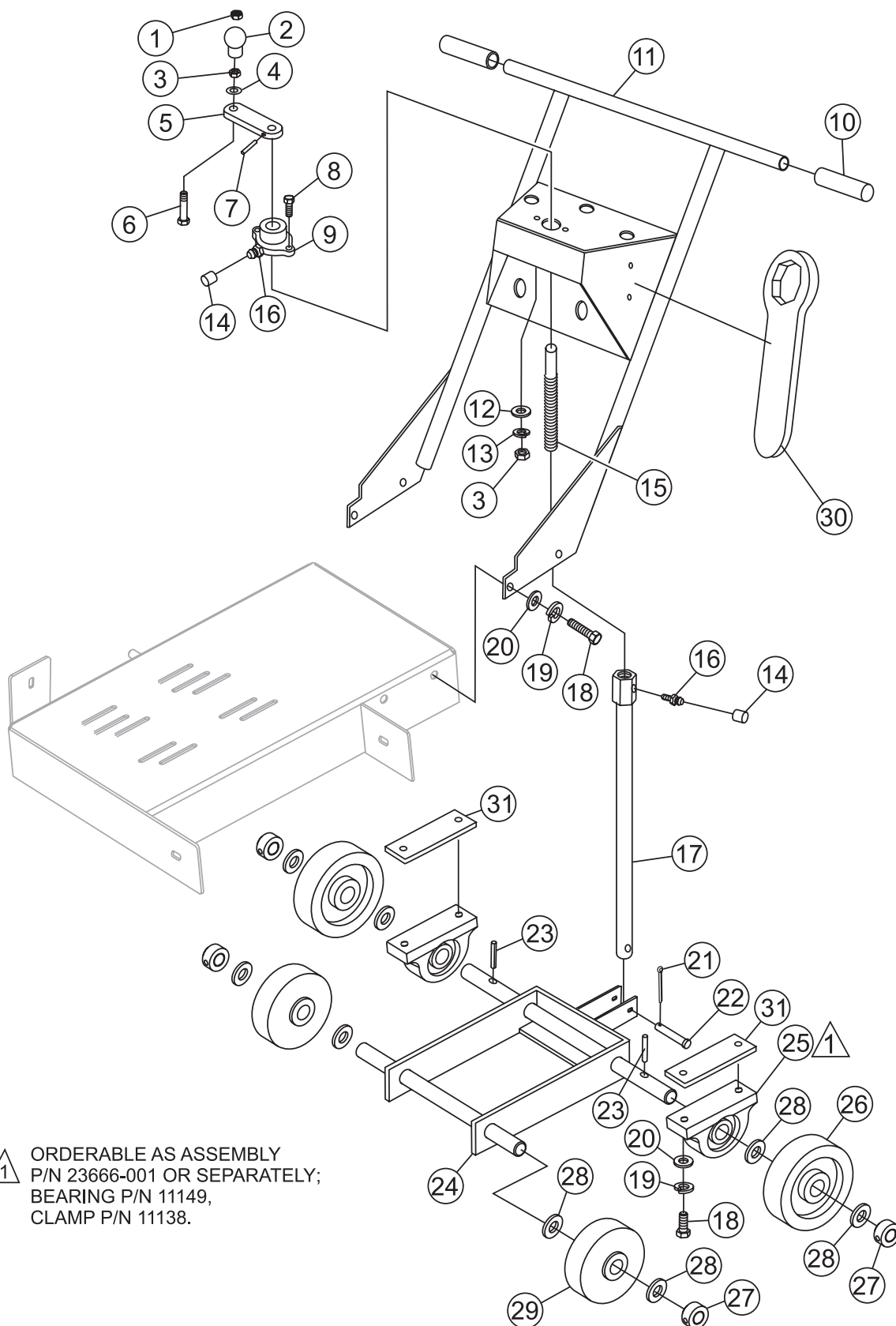

△ ORDERABLE AS ASSEMBLY  
P/N 23666-001 OR SEPARATELY;  
BEARING P/N 11149,  
CLAMP P/N 11138.

# STOW CUTTER 1 SAW — UNDERCARRIAGE ASSY.

## UNDERCARRIAGE ASSY.

<u>NO.</u>	<u>PART NO.</u>	<u>PART NAME</u>	<u>QTY.</u>	<u>REMARKS</u>
1	08233-005	LOCKNUT, 5/16 - 18	1	
2	18637-001	KNOB	1	
3	0161 D	HEX NUT, 5/16 - 18	3	
4	25496	BUSHING	1	
5	28808-002	CRANK HANDLE	1	
6	26164-001	LOCK PIN	1	
7	4568	ROLL PIN 3/16 X 1	1	
8	07046-011	BOLT, CARRIAGE 5/16-18 X 1-1/2	2	
9	23284-001	WRAPPER-BLADE GUARD	1	
10	20478	HAND GRIP	2	
11	26126-352	HANDLE	1	
12	0300 B	FLAT WASHER 5/16	2	
13	0161 C	LOCK WASHER 5/16	2	
14	1162 A	CAP, GREASE ZERK	4	
15	26137-002	ACME SCREW	1	
16	2621	ZERK, GREASE STR 1/4 - 28	1	
17	29408-352	JACK ARM (SUPPORT TUBE)	1	
18	0205	SCREW, HHCS 3/8 - 16 X 1-1/4	8	
19	0166 A	LOCK WASHER, 3/8	8	
20	10136	FLAT WASHER 3/8	8	
21	6014 B	COTTER PIN 3/32 X 1	1	
22	08326-019	PIN 3/8 X 2-5/16	1	
23	07402-024	ROLL PIN 1/8 X 1-1/2	2	
24	26120-352	WHEEL BASE ASSEMBLY	1	
25	23666-001	CLAMP & BEARING ASSEMBLY	2	
25A	11138	CLAMP ASSEMBLY	2	
25B	11149	BEARING	2	
26	23668-001	REAR WHEEL, (6X2 ELECTRIC MODEL)	2	
26	28086-001	REAR WHEEL, (8X2 GAS MODEL)	2	
27	26133-001	LOCKING COLLAR	4	
28	8151	FLAT WASHER, 3/4	6	
29	26121-001	FRONT WHEEL	2	
30	29013-001	1-1/2" BOX WRENCH	1	
31	25677	SPACER, REAR AXLE BEARING	2	

# STOW CUTTER 1 SAW — WATER SYSTEM AND BLADE ASSY.

WATER SYSTEM AND BLADE ASSY.

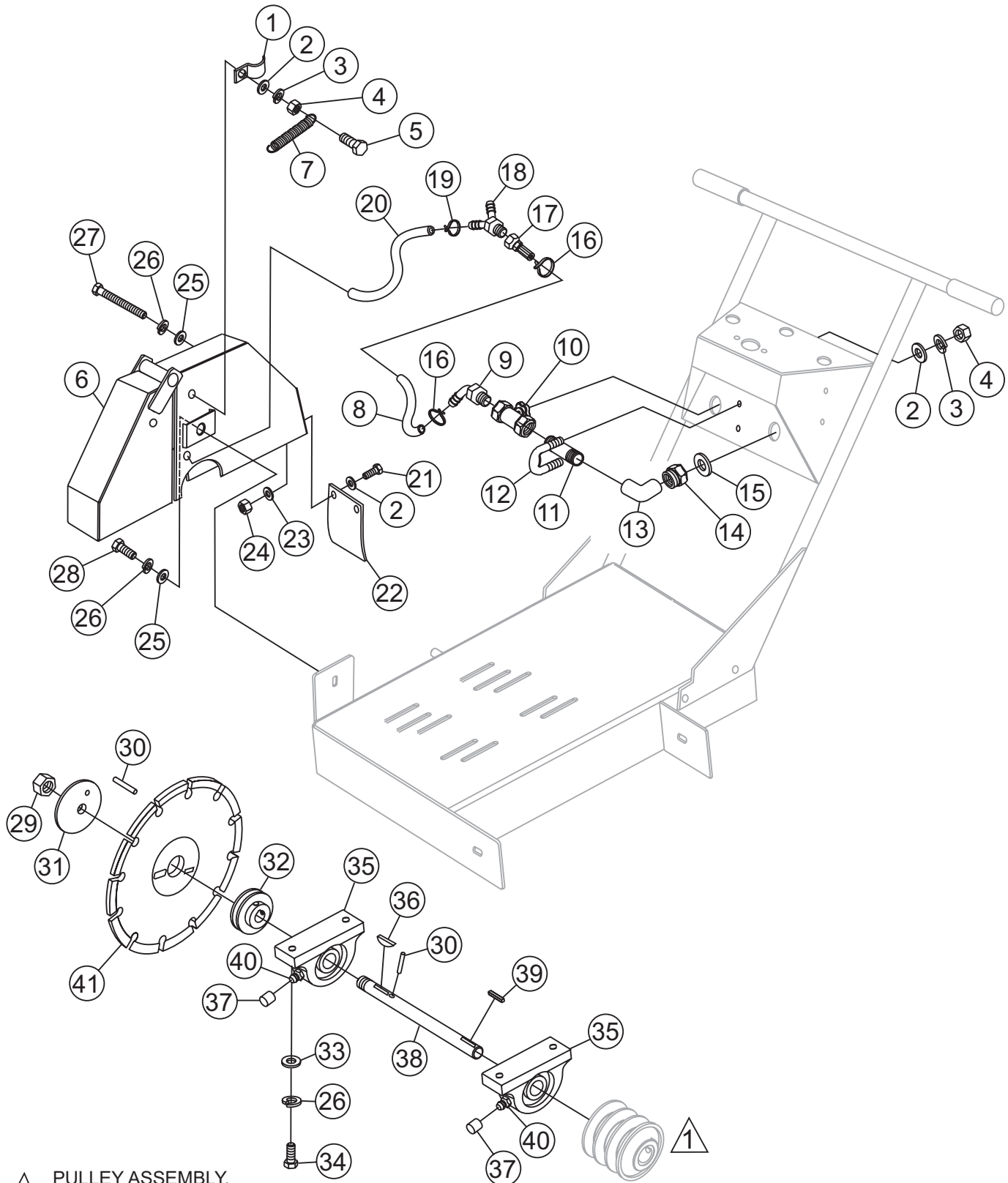

1 PULLEY ASSEMBLY.  
SEE PAGE 30.

# STOW CUTTER 1 SAW — WATER SYSTEM AND BLADE ASSY.

## WATER SYSTEM AND BLADE ASSY.

<u>NO.</u>	<u>PART NO.</u>	<u>PART NAME</u>	<u>QTY.</u>	<u>REMARKS</u>
1	22129-001	CLAMP	2	
2	0948	FLAT WASHER, 1/4	5	
3	0181 B	LOCK WASHER 1/4	5	
4	0949	HEX NUT 1/4 - 20	5	
5	0424	SCREW, HHCS 1/4 - 20 X 1	4	
6	29406-352	BLADE GUARD	1	
7	18626-001	SPRING	2	
8	23255-011	HOSE 26"	1	
9	23566-001	BARBED FITTING 90 DEG.	1	
10	35122-402	VALVE	1	
11	11708	NIPPLE 1/2	1	
12	16378-005	U-BOLT 1/4	1	
13	23252-002	ELBOW 1/2	1	
14	15544	CONNECTOR, GARDEN HOSE	1	
15	13336-001	WASHER, RUBBER	1	
16	12694-006	HOSE CLAMP	2	
17	24778-001	SWIVEL CONNECTOR	1	
18	24642-001	Y-FITTING	1	
19	12694-004	HOSE CLAMP	2	
20	60021 .....	HOSE, 1.0 FT. ....	2 .....	SOLD PER FOOT
21	0131 A	SCREW, HHCS 1/4 - 20 X 3/4	2	
22	28729-005	CHIP GUARD	1	
23	10930	FENDER WASHER 1/4	2	
24	10024	LOCKNUT, 1/4 - 20	2	
25	10136	FLAT WASHER 3/8	6	
26	0166 A	LOCK WASHER 3/8	2	
27	06501-032	SCREW, HHCS 3/8 - 16 X 4	1	
28	0205	SCREW, HHCS 3/8 - 16 X 1	1	
29	06922-003	NUT L.H. 1 - 1/4	1	
30	15046	DOWEL PIN 3/8 X 1-1/4	2	
31	26928-004	FLANGE, OUTER	1	
32	28811-001	FLANGE, INNER	1	
33	4001	FLAT WASHER	4	
34	1284	SCREW, HHCS 3/8 - 16 X 1-1/2	4	
35	3200	BEARING	2	
36	0125	WOODRUFF KEY 1/4 X 1	1	
37	1162 A	CAP, GREASE ZERK	2	
38	26135-002	SPINDLE	1	
39	9152	KEY 1/4 X 1-3/4	1	
40	2621	GREASE ZERK	2	
41	9SWG	BLADE, DIAMOND BACK	1	

# STOW CUTTER 1 SAW — POINTER ASSY.

POINTER ASSY.

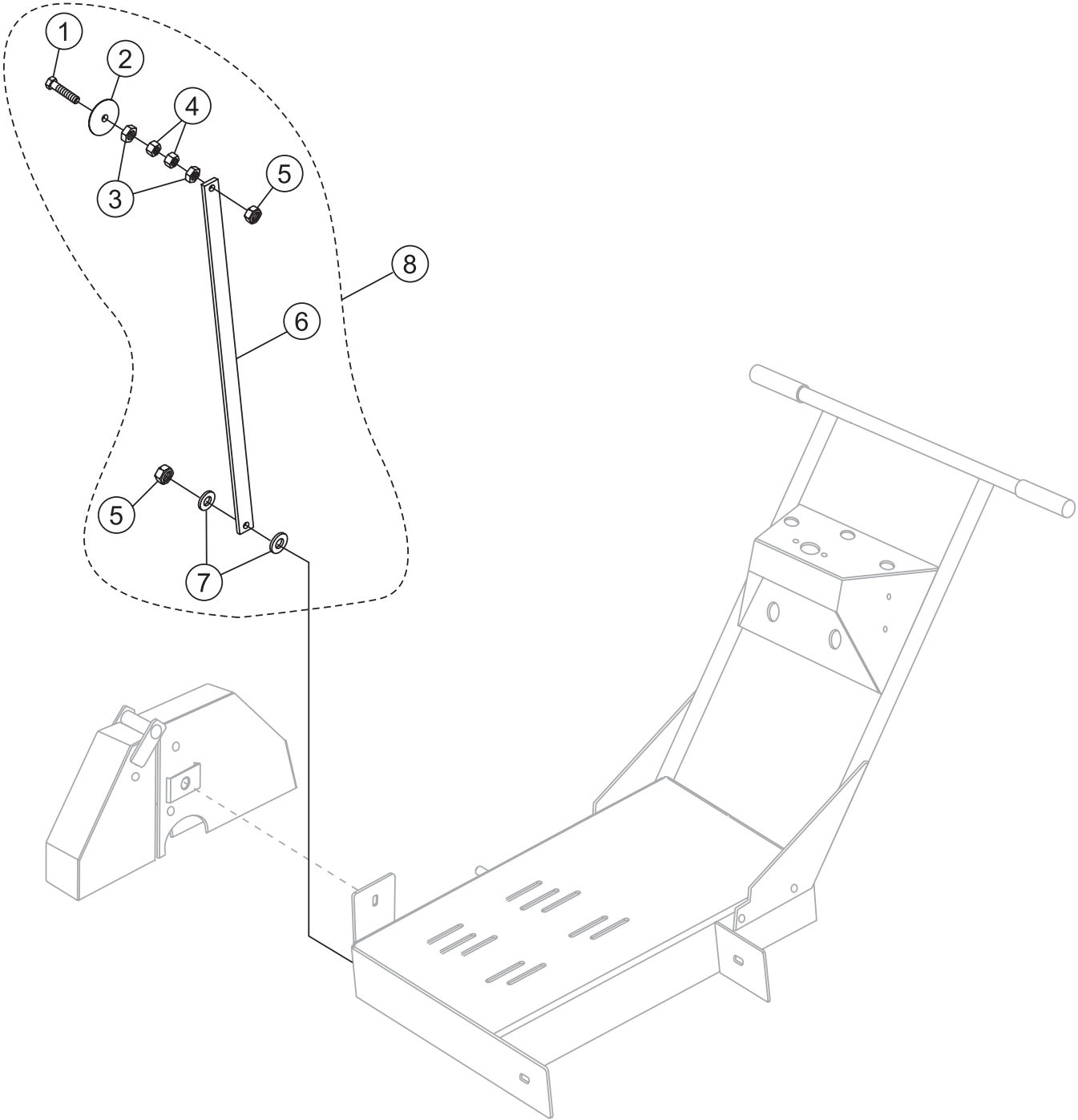

# STOW CUTTER 1 SAW — POINTER ASSY.

## POINTER ASSY.

<u>NO.</u>	<u>PART NO.</u>	<u>PART NAME</u>	<u>QTY.</u>	<u>REMARKS</u>
1 *	21017	SCREW, POINTER ARM	1	
2 *	29043-001	WHEEL, POINTER	1	
3 *	1007	NUT, HEX JAM 3/8 - 16	2	
4 *	1456	NUT, HEX FINISH 3/8 - 16	2	
5 *	10133	NUT, NYLOC 3/8 - 16	2	
6 *	27073-001	ARM, POINTER	1	
7 *	10136	WASHER, FLAT 3/8	2	
8	29042-501	INDICATOR ASSEMBLY .....	1 .....	INCLUDES ITEMS W/ *

# HONDA GX390K1QWT2/GX390U1QWT2 ENG. — AIR CLEANER ASSY.

AIR CLEANER ASSY.

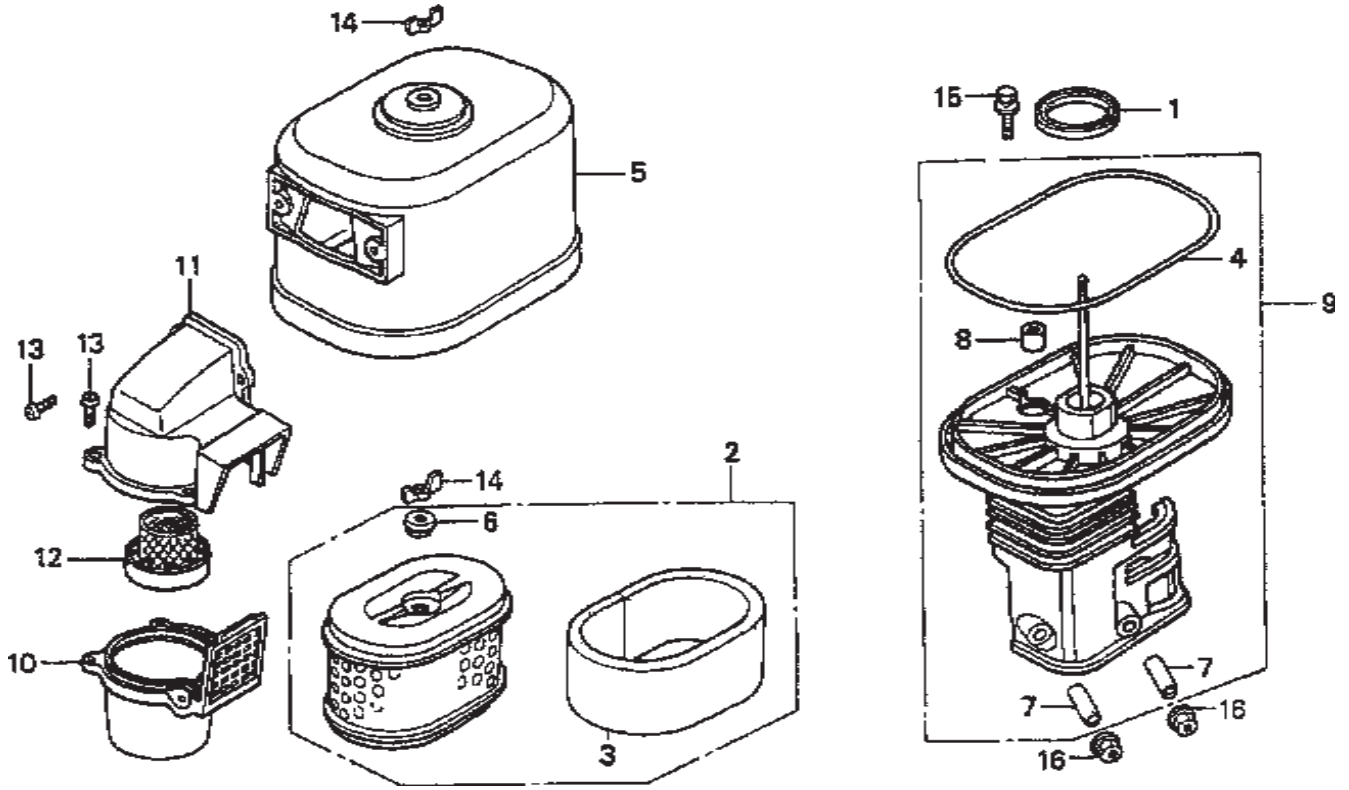



# HONDA GX390K1QWT2/GX390U1QWT2 ENG. — AIR CLEANER ASSY.

## AIR CLEANER ASSY.

<u>NO.</u>	<u>PART NO.</u>	<u>PART NAME</u>	<u>QTY.</u>	<u>REMARKS</u>
1✕	16271ZE2000	GASKET, ELBOW	1	
1◇	16271ZE2010	GASKET, ELBOW	1	
2	17210ZE3010	ELEMENT, AIR CLEANER .....	1	INCLUDES ITEMS W/*
3*	17218ZE3000	FILTER, OUTER	1	
4#	17219ZE3840	SEAL, AIR CLEANER COVER	1	
5	17230ZE3841	COVER, AIR CLEANER (CYCLONE)	1	
6*	17232891000	GROMMET, AIR CLEANER	1	
7#	17238ZE2310	COLLAR, AIR CLEANER	2	
8#	17239ZE3840	COLLAR B, AIR CLEANER	1	
9	17410ZE3840	ELBOW, AIR CLEANER .....	1	INCLUDES ITEMS W/#
10✕	17470ZE3841	CASE, PRE AIR CLEANER	1	
10◇	17470ZE3842	CASE, PRE AIR CLEANER	1	
11	17475ZE3841	CAP, PRE AIR CLEANER	1	
12	17476ZE3841	GUIDE, PRE AIR CLEANER	1	
13	90142MB0000	SCREW, PAN 5X16.5	5	
14	90325044000	WINGNUT, TOOL BOX SETTING	2	
15	90009ZE2003	BOLT- WASHER 6X22	1	
16	9405006000	NUT, FLANGE 6MM	2	

# HONDA GX390K1QWT2/GX390U1QWT2 ENG. — CAMSHAFT ASSY.

CAMSHAFT ASSY.

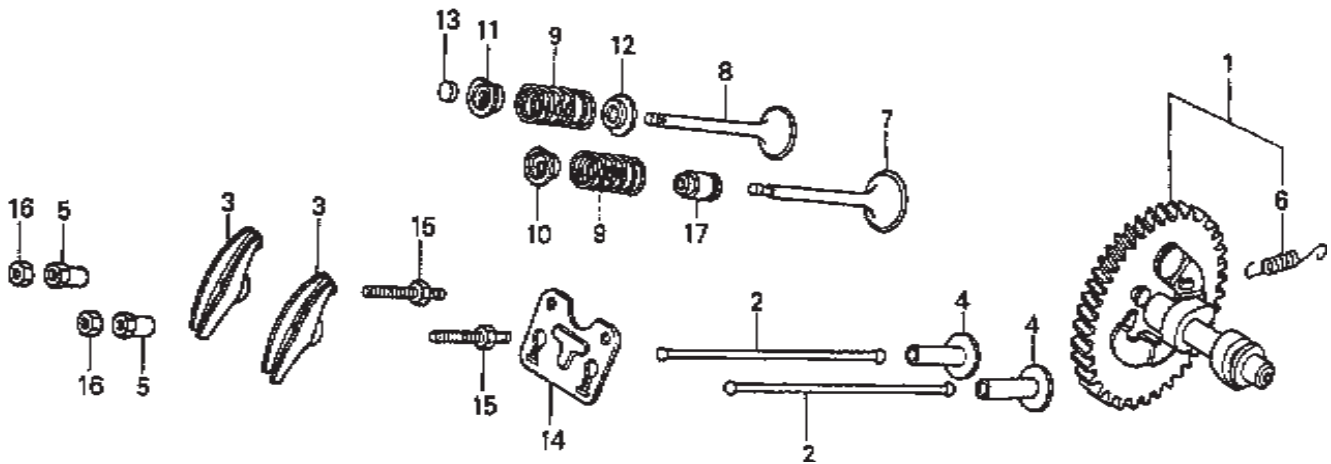

# HONDA GX390K1QWT2/GX390U1QWT2 ENG. — CAMSHAFT ASSY.

## CAMSHAFT ASSY.

<u>NO.</u>	<u>PART NO.</u>	<u>PART NAME</u>	<u>QTY.</u>	<u>REMARKS</u>
1	14100ZF6W01	CAMSHAFT ASSEMBLY .....	1 .....	INCLUDES ITEM W/*
2	14410ZE3013	ROD, PUSH	2	
3	14431ZE2010	ARM, VALVE ROCKER	2	
4	14441ZE2000	LIFTER, VALVE	2	
5	14451ZE1013	PIVOT, ROCKER ARM	2	
6*	14568ZE1000	SPRING, WEIGHT RETURN	1	
7	14711ZE3000	VALVE, INTAKE	1	
8	14721ZE3000	VALVE, EXHAUST	1	
9	14751ZE2003	SPRING, VALVE	2	
10	14771ZE2000	RETAINER,INTAKE VALVE SPRING	1	
11	14773ZE2000	RETAINER, EXHAUST VALVE SPRING	1	
12	14775ZE2010	SEAT, VALVE SPRING	1	
13	14781ZE2000	ROTATOR, VALVE	1	
14	14791ZE2010	PLATE, PUSH ROD GUIDE	1	
15	90012ZE0010	BOLT, PIVOT 8MM	2	
16	90206ZE1000	NUT, PIVOT ADJ.	2	
17	12209ZE8003	SEAL, VALVE STEM	1	

# HONDA GX390K1QWT2/GX390U1QWT2 ENG. — CARBURETOR ASSY.

CARBURETOR ASSY.

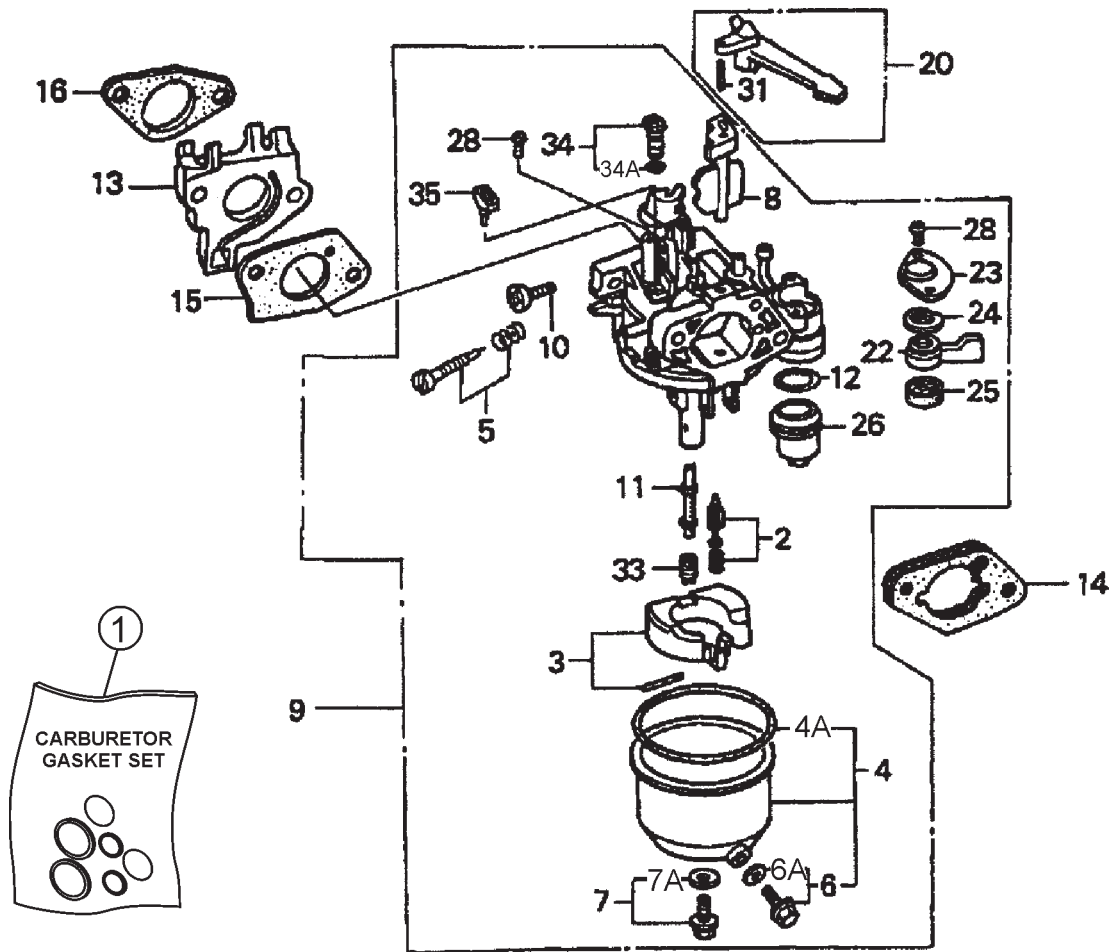

# HONDA GX390K1QWT2/GX390U1QWT2 ENG. — CARBURETOR ASSY.

## CARBURETOR ASSY.

<u>NO.</u>	<u>PART NO.</u>	<u>PART NAME</u>	<u>QTY.</u>	<u>REMARKS</u>
1	16010ZE2812	CARBURETOR, GASKET SET	1	INCLUDES ITEMS W/+
2\$	16011ZA0931	VALVE SET, FLOAT	1	
3\$	16013ZA0931	FLOAT SET	1	
4\$	16015ZE8005	CHAMBER SET, FLOAT .....	1 .....	INCLUDES ITEM 4A
		.....		INCLUDES ITEM W/>
4A+		GASKET, CHAMBER SET FLOAT .....		NOT SOLD SEPARATELY
5\$	16016ZH7W01	SCREW SET, PILOT	1	
6\$>	16024ZE1811	SCREW SET, DRAIN, .....	1 .....	INCLUDES ITEM 6A
6A+		GASKET, SCREW SET DRAIN .....		NOT SOLD SEPARATELY
7\$	16028ZE0005	SCREW SET .....	1 .....	INCLUDES ITEM 7A
7A+		GASKET, SCREW SET .....		NOT SOLD SEPARATELY
8\$	16044ZE3W20	CHOKE SET	1	
9\$	16100ZF6V21	CARBURETOR ASSY. (BE85C B) .....	1 .....	INCLUDES ITEMS W/\$
10\$	16124ZE0005	SCREW, THROTTLE STOP	1	
11\$	16166ZF6W10	NOZZLE, MAIN	1	
12\$+	16173001004	GASKET, FUEL STRAINER CUP	1	
13	16211ZF6000	INSULATOR, CARBURETOR	1	
14	16220ZA0702	SPACER, CARBURETOR	1	
15	16221ZF6800	GASKET, CARBURETOR	1	
16	16223ZE3W00	GASKET, INSULATOR	1	
20	16610ZE1000	LEVER, CHOKE (STD) .....	1 .....	INCLUDES ITEM W/*
22\$	16953ZE1812	LEVER, VALVE	1	
23\$	16954ZE1812	PLATE, LEVER SETTING	1	
24\$	16956ZE1811	SPRING, VALVE LEVER	1	
25\$+	16957ZE1812	GASKET, VALVE	1	
26\$	16967ZE0811	CUP, FUEL STRAINER	1	
28\$	93500030061H	SCREW, PAN (3X6)	2	
31*	9430520122	PIN, SPRING (2X12)	1	
33\$	99101ZH80950	JET, MAIN (#95) (OPTIONAL)	1	
33\$	99101ZH80980	JET, MAIN (#98) (OPTIONAL)	1	
33\$	99101ZH81000	JET, MAIN (#100)	1	
34\$	99204ZA00450	JET SET, PILOT (#45) .....	1 .....	INCLUDES ITEM 34A
34A+		GASKET, JET SET PILOT (#45) .....		NOT SOLD SEPARATELY
35\$	16172ZE3W10	COLLAR, SET	1	

# HONDA GX390K1QWT2/GX390U1QWT2 ENG. — CONTROL ASSY.

CONTROL ASSY.

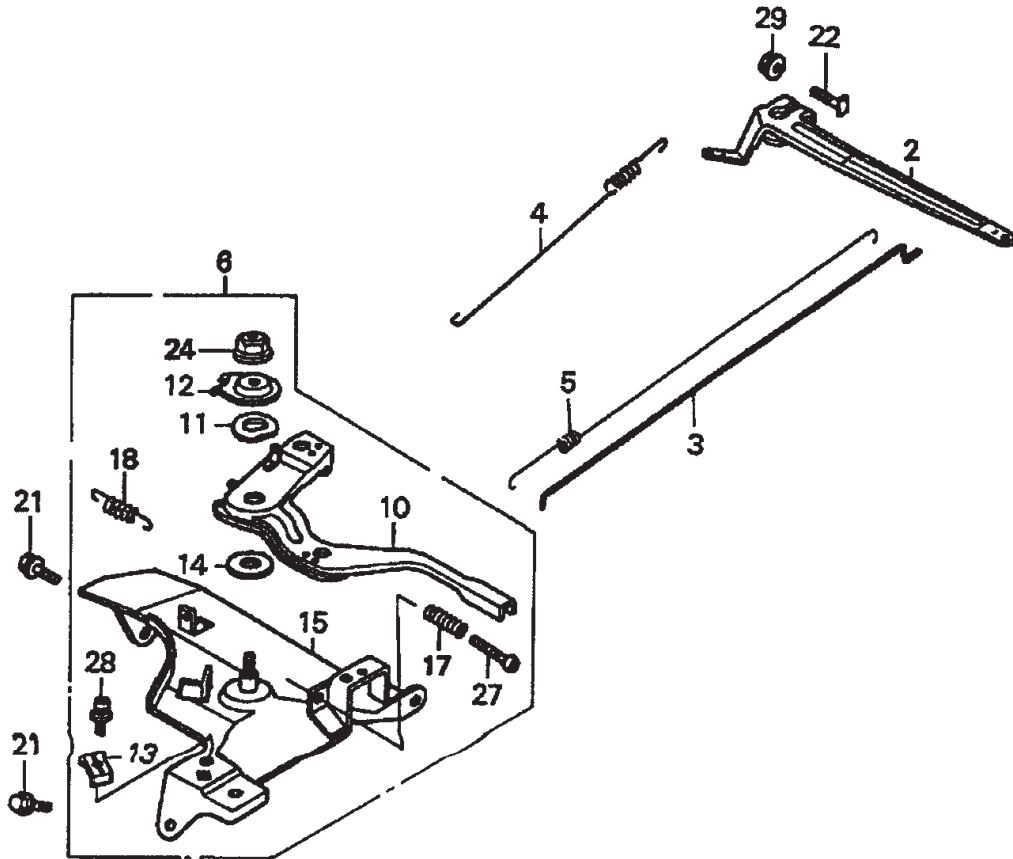

# HONDA GX390K1QWT2/GX390U1QWT2 ENG. — CONTROL ASSY.

## CONTROL ASSY.

<u>NO.</u>	<u>PART NO.</u>	<u>PART NAME</u>	<u>QTY.</u>	<u>REMARKS</u>
2	16551ZE3000	ARM, GOVERNOR	1	
3	16555ZE3000	ROD, GOVERNOR	1	
4	16561ZE3000	SPRING, GOVERNOR	1	
5	16562ZE3000	SPRING, THROTTLE RETURN	1	
6	16570ZE3W20	CONTROL ASSY. (REMOTE) .....	1	INCLUDES ITEMS W/*
10*	16571ZE3W00	LEVER, CONTROL	1	
11*	16574ZE1000	SPRING, LEVER	1	
12*	16575ZE2W00	WASHER, CONTROL LEVER	1	
13*	16576891000	HOLDER, CABLE	1	
14*	16578ZE1000	SPACER, CONTROL LEVER	1	
15*	16581ZE3W00	BASE, CONTROL	1	
17*	16584883300	SPRING, CONTROL ADJUSTING	1	
18*	16592883310	SPRING, CABLE RETURN	1	
21	90013883000	BOLT, FLANGE (6X12) (CT200)	2	
22	90015ZE5010	BOLT, GOVERNOR ARM	1	
24*	90114SA0000	NUT, SELF-LOCK (6MM)	1	
27*	93500050320A	SCREW, PAN (5X32)	1	
28*	93500050160A	SCREW, PAN (5X16)	1	
29	9405006000	NUT, FLANGE (6MM)	1	

# HONDA GX390K1QWT2/GX390U1QWT2 ENG. — CRANKCASE ASSY.

CRANKCASE COVER ASSY.

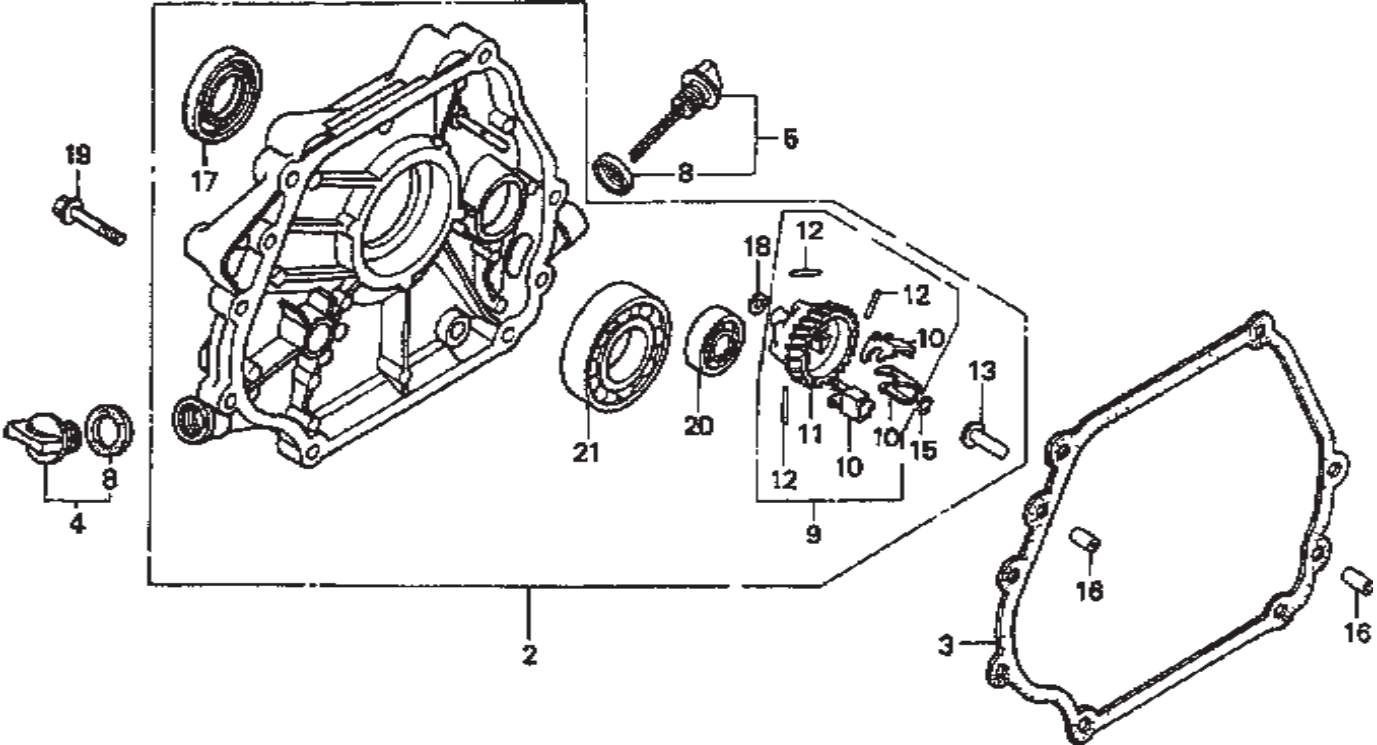



# HONDA GX390K1QWT2/GX390U1QWT2 ENG. — CRANKCASE ASSY.

## CRANKCASE COVER ASSY.

<u>NO.</u>	<u>PART NO.</u>	<u>PART NAME</u>	<u>QTY.</u>	<u>REMARKS</u>
2✕	11300ZE3602	COVER ASSY., CRANKCASE .....	1 .....	S/N 3287256 AND BELOW INCLUDES ITEMS W/>
2✕	11300ZE3604	COVER ASSY., CRANKCASE .....	1 .....	S/N 3287257 AND ABOVE INCLUDES ITEMS W/%
2◇	11300ZE3604	COVER ASSY., CRANKCASE .....	1 .....	INCLUDES ITEMS W/\$
3	11381ZE3801	GASKET, CASE COVER	1	
4	15600ZG4003	CAP ASSY., OIL FILLER .....	1 .....	INCLUDES ITEM W/#
5	15600735003	CAP ASSY., OIL FILLER .....	1 .....	INCLUDES ITEM W/*
8#*	15625ZE1003	GASKET, OIL FILLER CAP	2	
9	16510ZE3000	GOVERNOR ASSY.....	1 .....	INCLUDES ITEMS W/+
10>%\$+	16511ZE8000	WEIGHT, GOVERNOR	3	
11>%\$+	16512ZE3000	HOLDER, GOVERNOR WEIGHT	1	
12>%\$+	16513ZE2000	PIN, GOVERNOR WEIGHT	3	
13✕>%\$	16531ZE2000	SLIDER, GOVERNOR .....	1 .....	S/N 3287256 AND BELOW
13✕>%\$	16531Z0A000	SLIDER, GOVERNOR .....	1 .....	S/N 3287257 AND ABOVE
13◇>%\$	16531Z0A000	SLIDER, GOVERNOR	1	
15>%\$	90602ZE1000	CLIP, GOVERNOR HOLDER	1	
16	90701HC4000	PIN, DOWEL (8X12)	2	
17>%\$	91201ZE3004	OIL SEAL (35X52X8)	1	
18>%\$	9410106800	WASHER, PLAIN (6MM)	1	
19	957010804000	BOLT, FLANGE (8X40)	7	
20>%\$	961006202000	BEARING, RADIAL BALL (6202)	1	
21>%\$	961006207000	BEARING, RADIAL BALL (6207)	1	

# HONDA GX390K1QWT2/GX390U1QWT2 ENG. — CRANKSHAFT ASSY.

CRANKSHAFT ASSY.

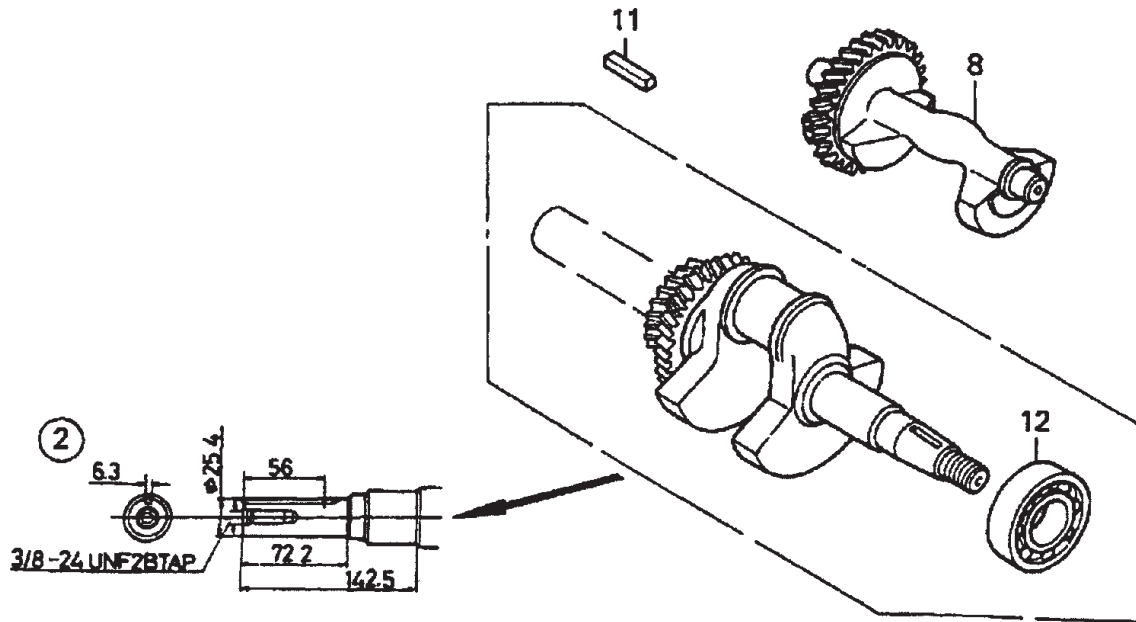

# HONDA GX390K1QWT2/GX390U1QWT2 ENG. — CRANKSHAFT ASSY.

## CRANKSHAFT ASSY.

<u>NO.</u>	<u>PART NO.</u>	<u>PART NAME</u>	<u>QTY.</u>	<u>REMARKS</u>
2✕	13310ZF6W10	CRANKSHAFT .....	1 .....	INCLUDES ITEM W/*
2◇	13310ZF6W11	CRANKSHAFT .....	1 .....	INCLUDES ITEM W/#
		.....		S/N 1113739 AND BELOW
2◇	13310ZF6W12	CRANKSHAFT .....	1 .....	INCLUDES ITEM W/+
		.....		S/N 1113740 AND ABOVE
8	13351ZE3010	WEIGHT, BALANCER	1	
11	90745ZE2600	KEY(6.3X6.3X43)	1	
12✕*	91001ZF6003	BEARING, RADIAL BALL (6207S)	1	
12◇#	91001ZF6003	BEARING, RADIAL BALL (6207S) .....	1 .....	S/N 1113739 AND BELOW
12◇+	91001ZF6013	BEARING, RADIAL BALL (6207SH) .....	1 .....	S/N 1113740 AND ABOVE

# HONDA GX390K1QWT2/GX390U1QWT2 ENG. — CYLINDER BARREL ASSY.

CYLINDER BARREL ASSY.

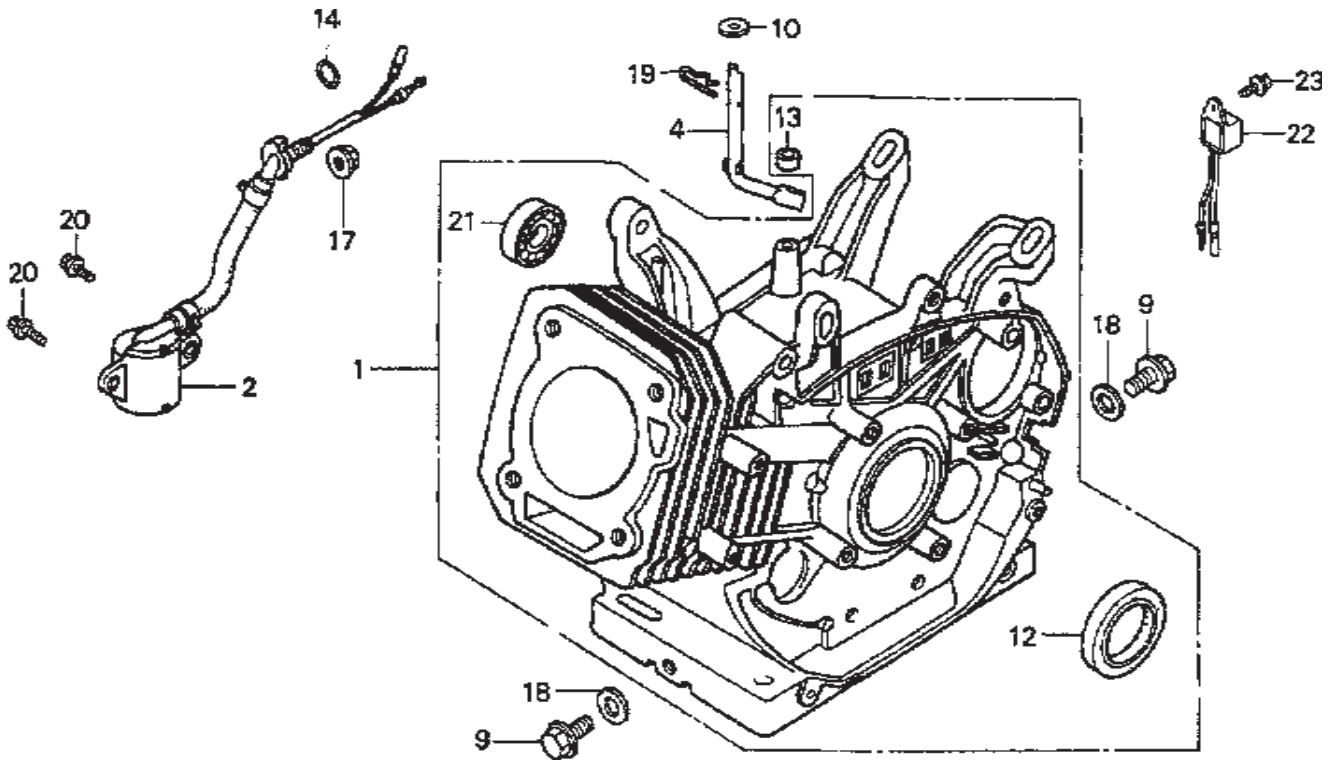

# HONDA GX390K1QWT2/GX390U1QWT2 ENG. — CYLINDER BARREL ASSY.

## CYLINDER BARREL ASSY.

<u>NO.</u>	<u>PART NO.</u>	<u>PART NAME</u>	<u>QTY.</u>	<u>REMARKS</u>
1✖	12000ZF6W13	CYLINDER ASSY. (ALERT) .....	1 .....	INCLUDES ITEMS W/%
1◇	12000ZF6417	CYLINDER ASSY. ....	1 .....	INCLUDES ITEMS W/#
2✖	15510ZE2043	SWITCH ASSY., OIL LEVEL	1	
2◇	15510ZE2043	SWITCH ASSY., OIL LEVEL .....	1 .....	S/N 1412956 AND BELOW
2◇	15510ZE2053	SWITCH ASSY., OIL LEVEL .....	1 .....	S/N 1412957 AND ABOVE
4	16541ZE3010	SHAFT, GOVERNOR ARM	1	
9	90131883000	BOLT, DRAIN PLUG 12X15	2	
10	90446KE1000	WASHER (8.2X17X0.8)	1	
12%#	91201ZE3004	OIL SEAL (35X52X8)	1	
13	91203952771	OIL SEAL (8X14X5)	1	
14	91353671004	O-RING (14MM) (NOK)	1	
17	9405010000	NUT, FLANGE (10MM)	1	
18	9410912000	WASHER, DRAIN PLUG (12MM)	2	
19	9425110000	PIN, LOCK (10MM)	1	
20	957010601200	BOLT, FLANGE (6X12)	2	
21%#	961006202000	BEARING, RADIAL BALL (6202)	1	
22✖	34150ZH7003	ALERT UNIT, OIL	1	
22◇	34150ZH7003	ALERT UNIT, OIL .....	1 .....	S/N 1419413 AND BELOW
22◇	34150ZH7013	ALERT UNIT, OIL .....	1 .....	S/N 1419414 AND ABOVE
23	90013883000	BOLT, FLANGE (6X12) (CT200)	1	

# HONDA GX390K1QWT2/GX390U1QWT2 ENG. — CYLINDER HEAD ASSY.

CYLINDER HEAD ASSY.

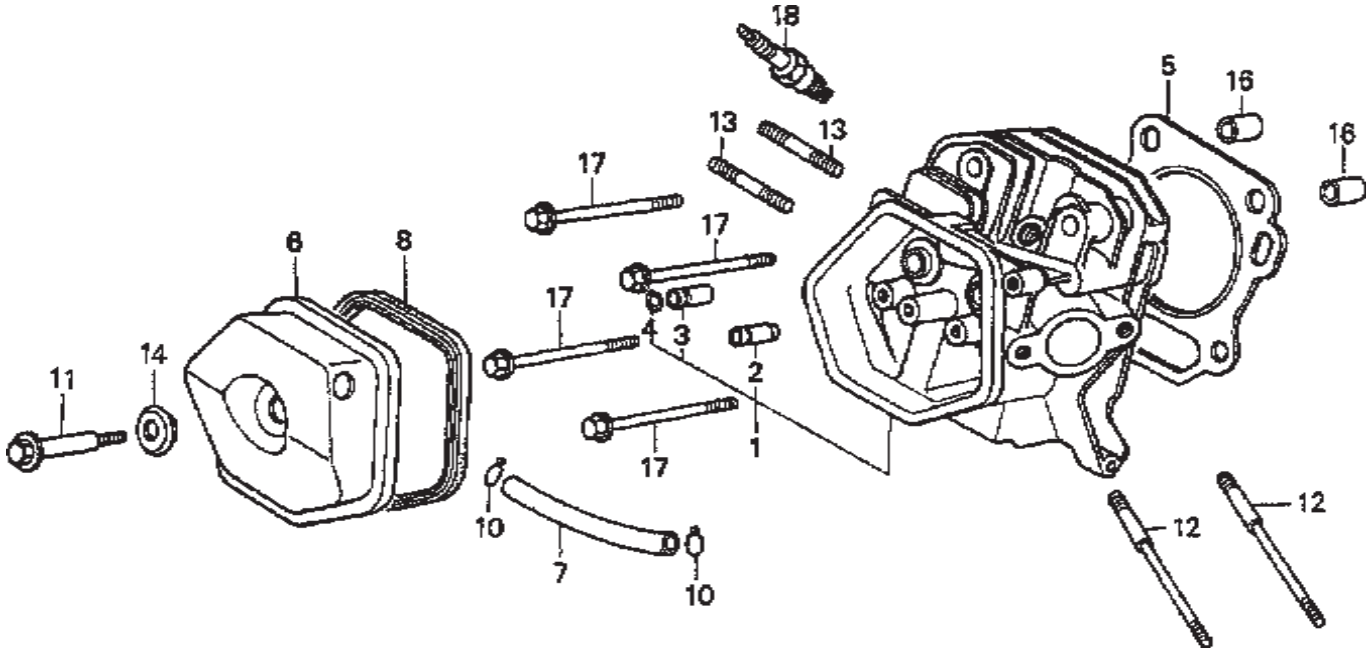

# HONDA GX390K1QWT2/GX390U1QWT2 ENG. — CYLINDER HEAD ASSY.

## CYLINDER HEAD ASSY.

<u>NO.</u>	<u>PART NO.</u>	<u>PART NAME</u>	<u>QTY.</u>	<u>REMARKS</u>
1✖	12200ZF6W01	CYLINDER HEAD .....	1 .....	INCLUDES ITEMS W/*
1◇	12200ZF6406	CYLINDER HEAD .....	1 .....	INCLUDES ITEMS W/%
2*%	12204ZE2306	GUIDE, VALVE (OS) (OPTIONAL)	1	
3*%	12205ZE2305	GUIDE, EX. VALVE (OS) (OPTIONAL)	1	
4*%	12216ZE2300	CLIP, VALVE GUIDE	1	
5	12251ZF6W00	GASKET, CYLINDER HEAD	1	
6	12310ZE3791	COVER, HEAD	1	
7	12315ZE3840	TUBE, BREATHER	1	
8	12391ZE2020	GASKET, CYLINDER HEAD COVER	1	
10	17316611000	CLIP, BREATHER TUBE	2	
11	90014ZE2000	BOLT, HEAD COVER	1	
12	90042ZE8000	BOLT, STUD (8X131.5)	2	
13	92900080320E	BOLT 2, STUD (8X32)	2	
14	90441ZE2010	WASHER, HEAD COVER	1	
16	9430112200	PIN A, DOWEL (12X20)	2	
17✖	957251008000	BOLT, FLANGE (10X80)	4	
17◇	957251008000	BOLT, FLANGE (10X80) .....	4 .....	S/N 1411816 AND BELOW
17◇	957011008000	BOLT, FLANGE (10X80) .....	4 .....	S/N 1411817 AND ABOVE
18	9807955846	SPARK PLUG (BPR5ES) (NGK) (OPT.)	1	
18	9807955855	SPARK PLUG (W16EPR-U) (DENSO)	1	
18	9807956846	SPARK PLUG (BPR6ES) (NGK)	1	
18	9807956855	SPARK PLUG (W20EPR-U) (DENSO)	1	

# HONDA GX390K1QWT2/GX390U1QWT2 ENG. — FAN COVER ASSY.

FAN COVER ASSY.

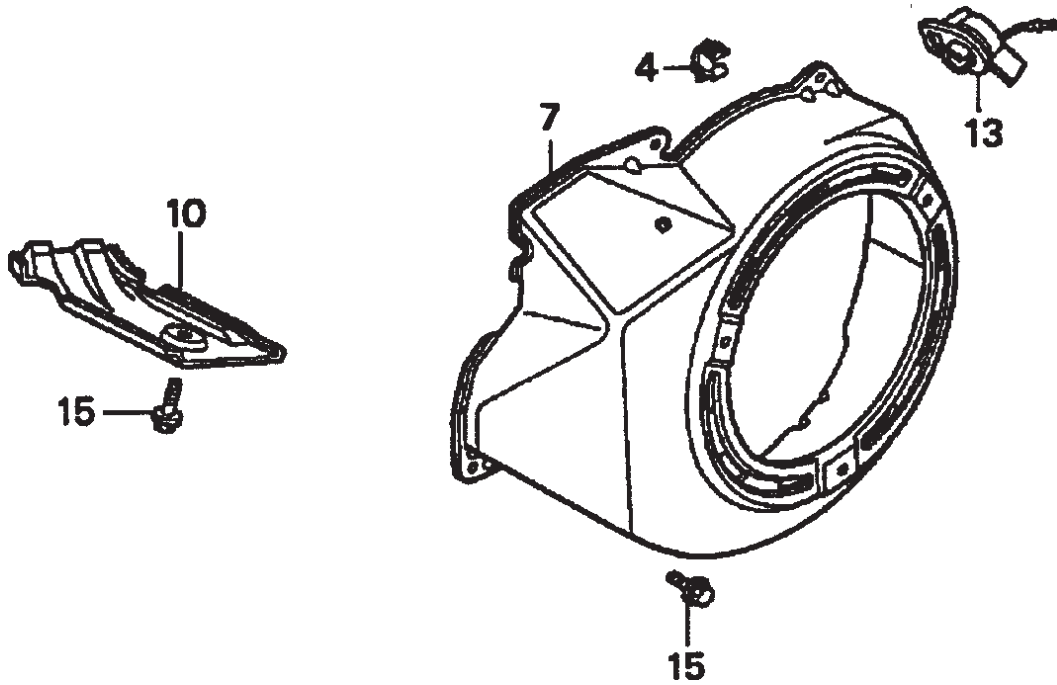



# HONDA GX390K1QWT2/GX390U1QWT2 ENG. — FAN COVER ASSY.

FAN COVER ASSY.

<u>NO.</u>	<u>PART NO.</u>	<u>PART NAME</u>	<u>QTY.</u>	<u>REMARKS</u>
4	16731ZE2003	CLIP, TUBE	1	
7	19610ZE3010ZB	COVER, FAN *NH1* (BLACK)	1	
10	19631ZE3W00	SHROUD	1	
13✕	36100ZH7003	SWITCH ASSY., ENGINE STOP	1	
13◇	36100ZF6P81	SWITCH ASSY., ENGINE STOP .....	1 .....	S/N 1412956 AND BELOW
13◇	36100ZF6P82	SWITCH ASSY., ENGINE STOP .....	1 .....	S/N 1412957 AND ABOVE
15	90013883000	BOLT, FLANGE (6X12) (CT200)	6	

# HONDA GX390K1QWT2/GX390U1QWT2 ENG. — FLYWHEEL ASSY.

FLYWHEEL ASSY.

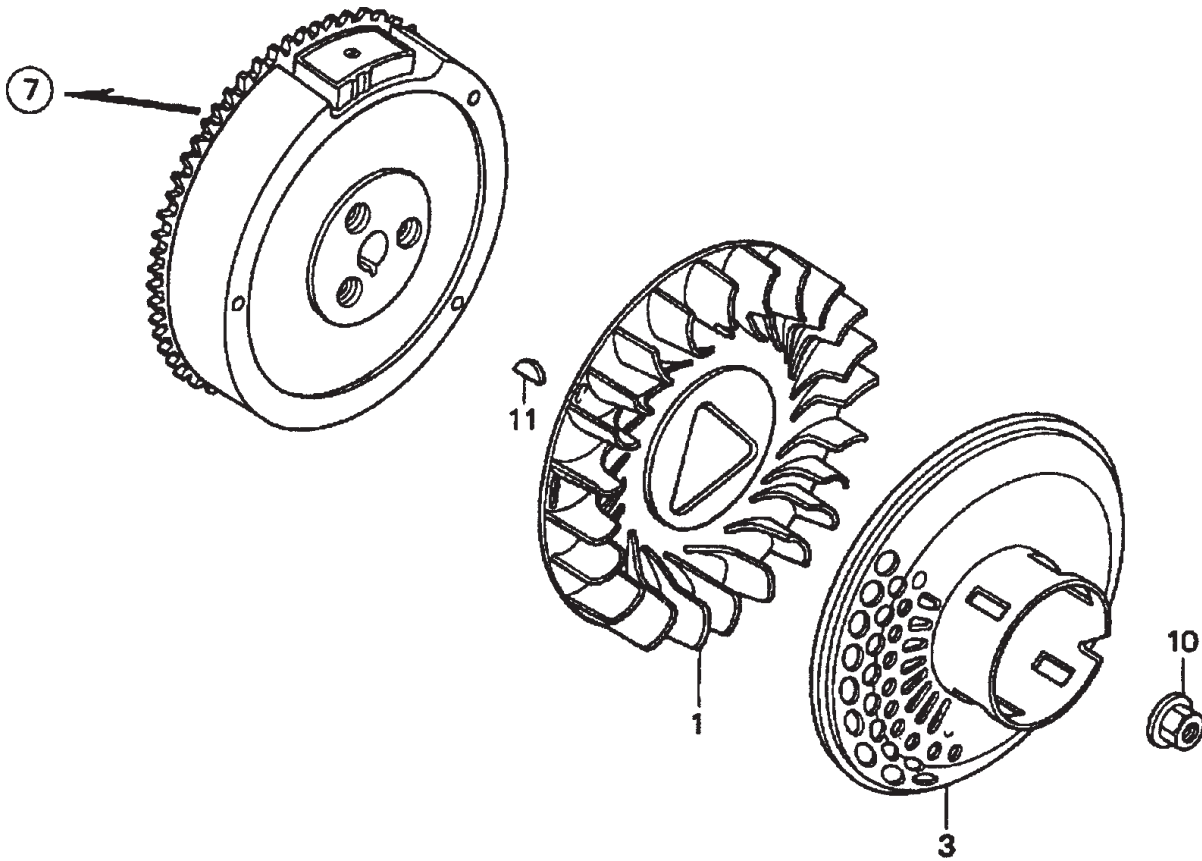

# HONDA GX390K1QWT2/GX390U1QWT2 ENG. — FLYWHEEL ASSY.

FLYWHEEL ASSY.

<u>NO.</u>	<u>PART NO.</u>	<u>PART NAME</u>	<u>QTY.</u>	<u>REMARKS</u>
1	19511ZE3000	FAN, COOLING	1	
3	28450ZE3W11	PULLEY, STARTER (SCREEN GRID)	1	
7	31100ZE3701	FLYWHEEL	1	
10✕	90201ZE3V00	NUT, SPECIAL (16MM) (1)	1	
10◇	90201ZE3V00	NUT, SPECIAL (16MM) (1) .....	1 .....	S/N 1317976 AND BELOW
10◇	90201ZE3790	NUT, SPECIAL (16MM) (1) .....	1 .....	S/N 1317977 AND ABOVE
11	90741ZE2000	KEY, SPECIAL WOODRUFF (25X18)	1	

# HONDA GX390K1QWT2/GX390U1QWT2 ENG. — FUEL TANK ASSY.

FUEL TANK ASSY.

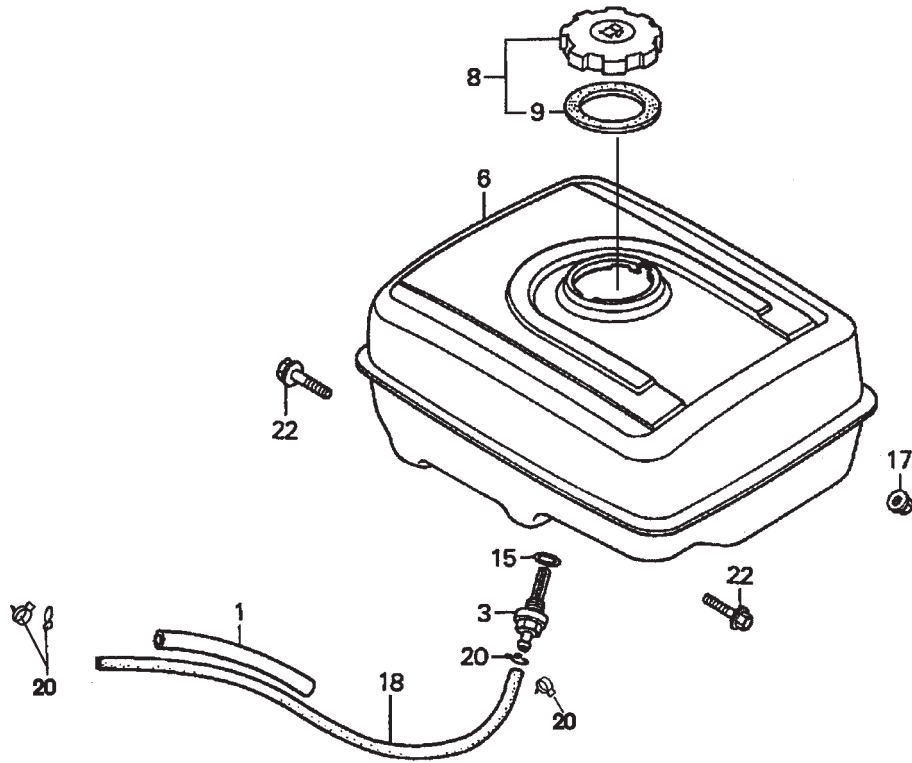

# HONDA GX390K1QWT2/GX390U1QWT2 ENG. — FUEL TANK ASSY.

## FUEL TANK ASSY.

<u>NO.</u>	<u>PART NO.</u>	<u>PART NAME</u>	<u>QTY.</u>	<u>REMARKS</u>
1	16854ZH8000	RUBBER, SUPPORTER (107MM)	1	
3	16955ZE1000	JOINT, FUEL TANK	1	
6✖	17510ZE3010ZB	TANK, FUEL *NH1*	1	
6◇	17510ZE3020ZB	TANK, FUEL *NH1* .....	1	S/N 1213085 AND BELOW
6◇	17510ZE3800ZA	TANK, FUEL *NH1* .....	1	S/N 1213086 THRU 1383799
6◇	17510ZE3801ZA	TANK, FUEL *NH1* .....	1	S/N 1383800 AND ABOVE
8✖	17620ZH7023	CAP, FUEL FILLER (BLACK) .....	1	INCLUDES ITEM W/*
8◇	17620Z0T305	CAP, FUEL FILLER (CHROME PLATED) .....	1	INCLUDES ITEM W/#
9*	17631ZH7003	GASKET, FUEL FILLER CAP	1	
9#	17631Z0T812	GASKET, FUEL FILLER CAP 39X62X3	1	
15	91353671004	O-RING (14MM) (NOK)	1	
17	9405008000	NUT, FLANGE (8MM)	2	
18✖	950014523540	BULK HOSE, FUEL (4.5X235) .....	1	REPLACES 950014500160M
18◇	950014523540	BULK HOSE, FUEL (4.5X235) .....	1	REPLACES 950014500160M
		.....		S/N 1105013 AND BELOW
18◇	91424Z5L801	BULK HOSE, FUEL (4.5X235) (FKM) .....	1	S/N 1105014 AND ABOVE
20✖	9500202080	CLIP, TUBE (B8)	2	
20◇	9500202080	CLIP, TUBE (B8) .....	2	S/N 1105013 AND BELOW
20◇	950024080008	CLAMP, TUBE (D8) .....	2	S/N 1105014 AND ABOVE
22	957010802500	BOLT, FLANGE (8X25)	2	

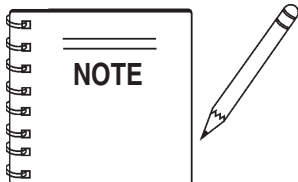

- ✖ GX390K1QWT2: Model S/N DECEMBER 2005 AND BELOW
- ◇ GX390U1QWT2: Model S/N JANUARY 2006 AND ABOVE

# HONDA GX390K1QWT2/GX390U1QWT2 ENG. — IGNITION COIL ASSY.

IGNITION COIL ASSY.

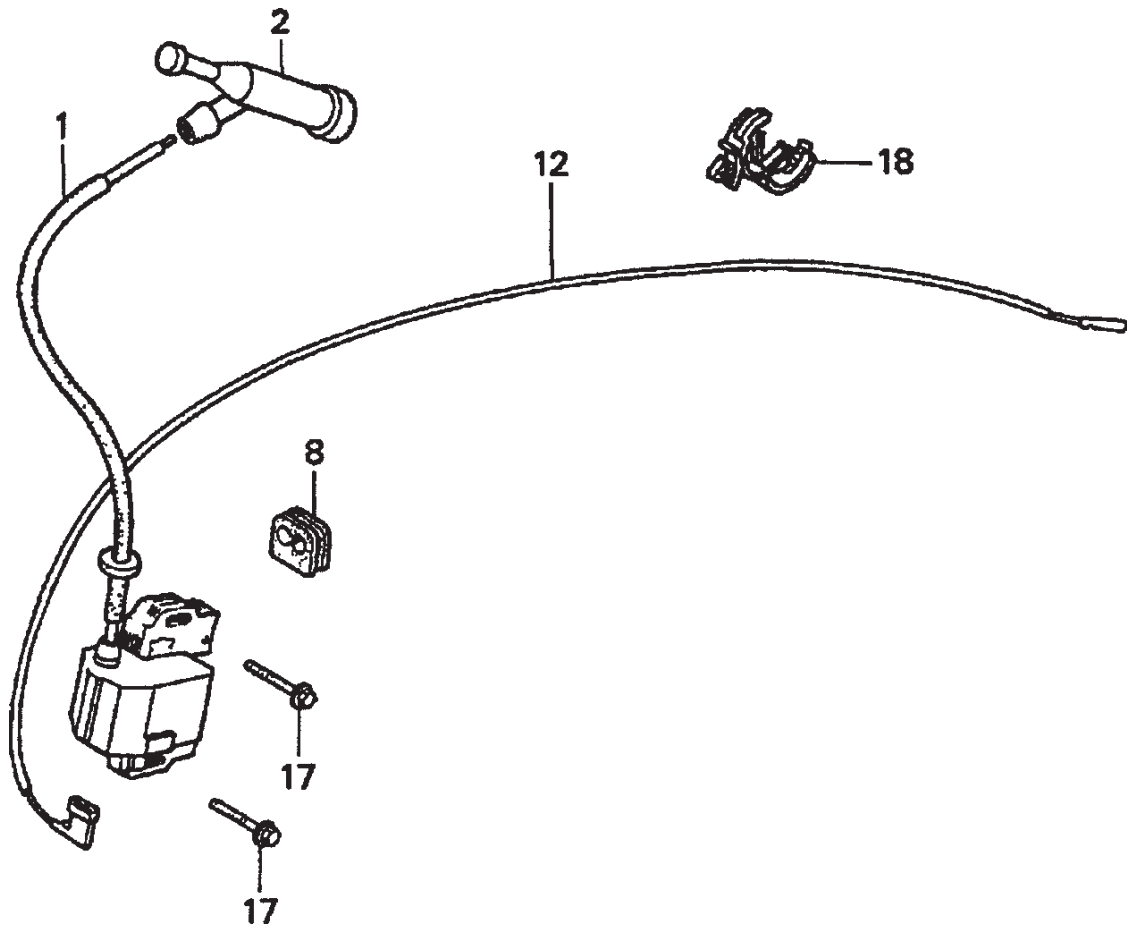

# HONDA GX390K1QWT2/GX390U1QWT2 ENG. — IGNITION COIL ASSY.

## IGNITION COIL ASSY.

<u>NO.</u>	<u>PART NO.</u>	<u>PART NAME</u>	<u>QTY.</u>	<u>REMARKS</u>
1✖	30500ZF6W02	COIL ASSY., IGNITION	1	
1◇	30500ZF6W02	COIL ASSY., IGNITION .....	1.....	S/N 1411816 AND BELOW
1◇	30500ZF6W03	COIL ASSY., IGNITION .....	1.....	S/N 1411817 AND ABOVE
2	30700ZE1013	CAP ASSY., NOISE SUPPRESSOR	1	
8	31512ZE2000	GROMMET, WIRE	1	
12	36101ZE2701	WIRE, STOP SWITCH (430MM)	1	
17	90015883000	BOLT, FLANGE (6X28)	2	
18	90684ZA0601	CLIP, WIRE HARNESS	1	

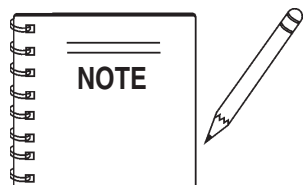

- ✖ GX390K1QWT2: Model S/N DECEMBER 2005 AND BELOW
- ◇ GX390U1QWT2: Model S/N JANUARY 2006 AND ABOVE

# HONDA GX390K1QWT2/GX390U1QWT2 ENG. — MUFFLER ASSY.

MUFFLER ASSY.

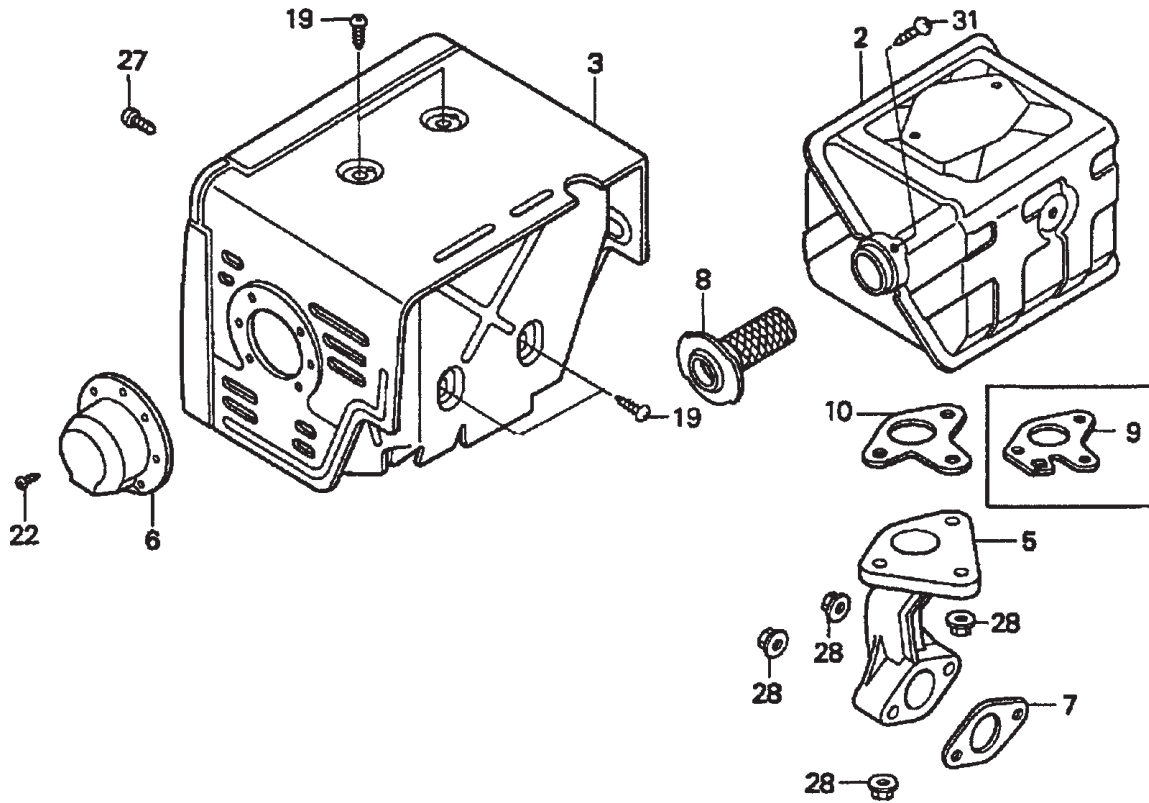



# HONDA GX390K1QWT2/GX390U1QWT2 ENG. — MUFFLER ASSY.

## MUFFLER ASSY.

<u>NO.</u>	<u>PART NO.</u>	<u>PART NAME</u>	<u>QTY.</u>	<u>REMARKS</u>
2	18310ZE2W61	MUFFLER	1	
3	18320ZE2W61	PROTECTOR, MUFFLER	1	
5	18330ZE2W00	PIPE, EX.	1	
6✕	18331ZE3810	CAP, MUFFLER	1	
6◇	18331ZE3810	CAP, MUFFLER .....	1	S/N 1166160 AND BELOW
6◇	18331ZE3811	CAP, MUFFLER .....	1	S/N 1166161 AND ABOVE
7	18333ZF6W01	GASKET, EX. PIPE	1	
8	18355ZE2W00	ARRESTER, SPARK (OPTIONAL)	1	
9	18381ZE2W10	GASKET, MUFFLER (ARRESTER) (OPTIONAL)	1	
10	18381ZE2800	GASKET, MUFFLER	1	
19	90050ZE1000	SCREW, TAPPING (5X8)	4	
22	90055ZE1000	SCREW, TAPPING (4X6)	3	
27	90006ZE2000	SCREW, TAPPING (6X10)	1	
28	9405008000	NUT, FLANGE (8MM)	5	
31	90055ZE1000	SCREW, TAPPING (4X6)	1	

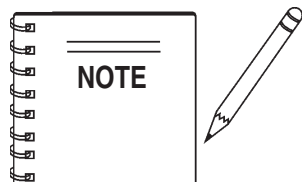

- ✕ GX390K1QWT2: Model S/N DECEMBER 2005 AND BELOW
- ◇ GX390U1QWT2: Model S/N JANUARY 2006 AND ABOVE

# HONDA GX390K1QWT2/GX390U1QWT2 ENG. — PISTON ASSY.

PISTON ASSY.

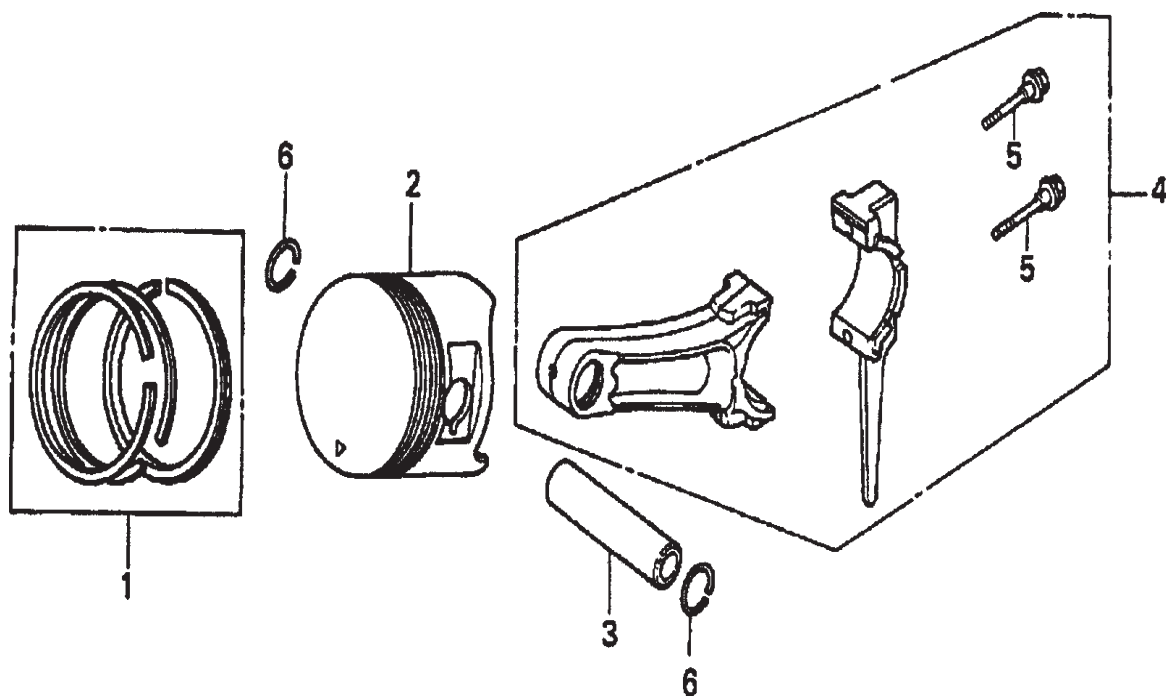

# HONDA GX390K1QWT2/GX390U1QWT2 ENG. — PISTON ASSY.

PISTON ASSY.

<u>NO.</u>	<u>PART NO.</u>	<u>PART NAME</u>	<u>QTY.</u>	<u>REMARKS</u>
1	13010ZF6005	RING SET, PISTON (STD)	1	
1	13011ZF6005	RING SET, PISTON (0.25)	1	
1	13012ZF6005	RING SET, PISTON (0.50)	1	
1	13013ZF6005	RING SET, PISTON (0.75)	1	
2	13101ZF6W00	PISTON (STD)	1	
2	13102ZF6W00	PISTON (0.25)	1	
2	13103ZF6W00	PISTON (0.50)	1	
2	13104ZF6W00	PISTON (0.75)	1	
3	13111ZF6W00	PIN, PISTON	1	
4	13200ZE3020	ROD ASSY., CONNECTING (STD) .....	1	INCLUDES ITEM W/*
4	13200ZE3315	ROD ASSY., CONNECTING (0.25 UNDERSIZE)	1	
5*	90001ZE8000	BOLT, CONNECTING ROD	2	
6	90601ZE3000	CLIP, PISTON PIN (20MM)	2	

# HONDA GX390K1QWT2/GX390U1QWT2 ENG. — RECOIL STATER ASSY.

RECOIL STARTER ASSY.

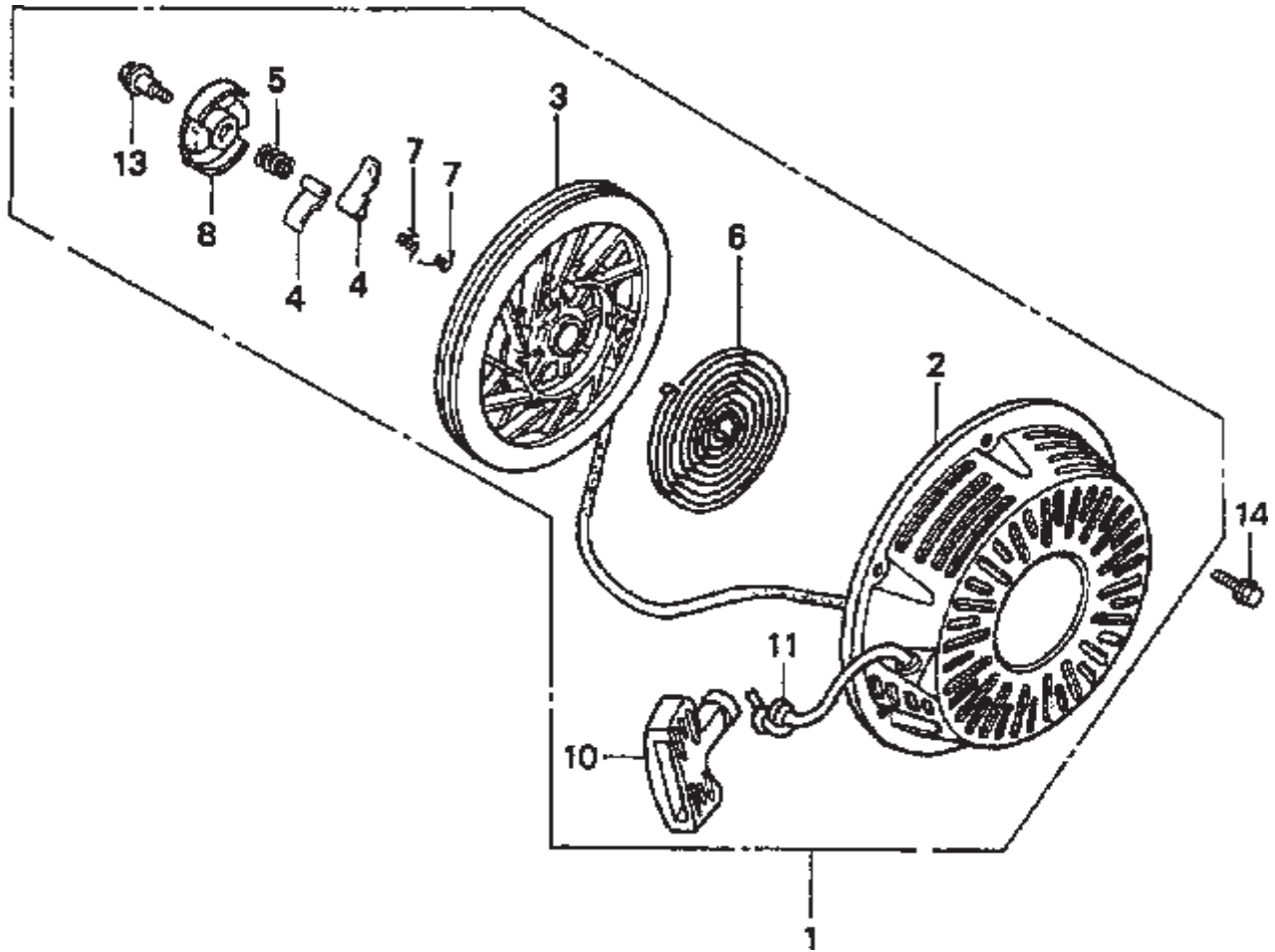

# HONDA GX390K1QWT2/GX390U1QWT2 ENG. — RECOIL STATER ASSY.

## RECOIL STARTER ASSY.

<u>NO.</u>	<u>PART NO.</u>	<u>PART NAME</u>	<u>QTY.</u>	<u>REMARKS</u>
1	28400ZE3W01ZB	STARTER ASSY., RECOIL *NH1* (BLACK) .....	1	INCLUDES ITEMS W/*
2*	28410ZE3W01ZB	CASE, RECOIL STARTER *NH1* (BLACK)	1	
3*	28421ZE3W01	PULLEY, RECOIL STARTER	1	
4*	28422ZE2W01	RATCHET, STARTER	2	
5*	28441ZE2W01	SPRING, FRICTION	1	
6*	28442ZE2W01	SPRING, STARTER RETURN	1	
7*	28443ZE2W01	SPRING, RATCHET	2	
8*	28444ZE2W01	RETAINER, SPRING	1	
10*	28461ZE2W02	GRIP, STARTER	1	
11**	28462ZV7003	ROPE, RECOIL STARTER	1	
11◇*	28462ZE3W01	ROPE, RECOIL STARTER	1	
13*	90004ZE2W01	SCREW, CENTER	1	
14	90008ZE2003	BOLT, FLANGE (6X10)	3	

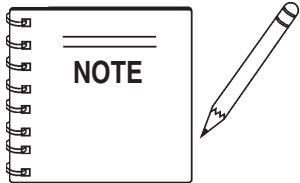

- \*\* GX390K1QWT2: Model S/N DECEMBER 2005 AND BELOW
- ◇ GX390U1QWT2: Model S/N JANUARY 2006 AND ABOVE

# HONDA GX390K1QWT2/GX390U1QWT2 ENG. — LABELS ASSY.

LABELS ASSY.

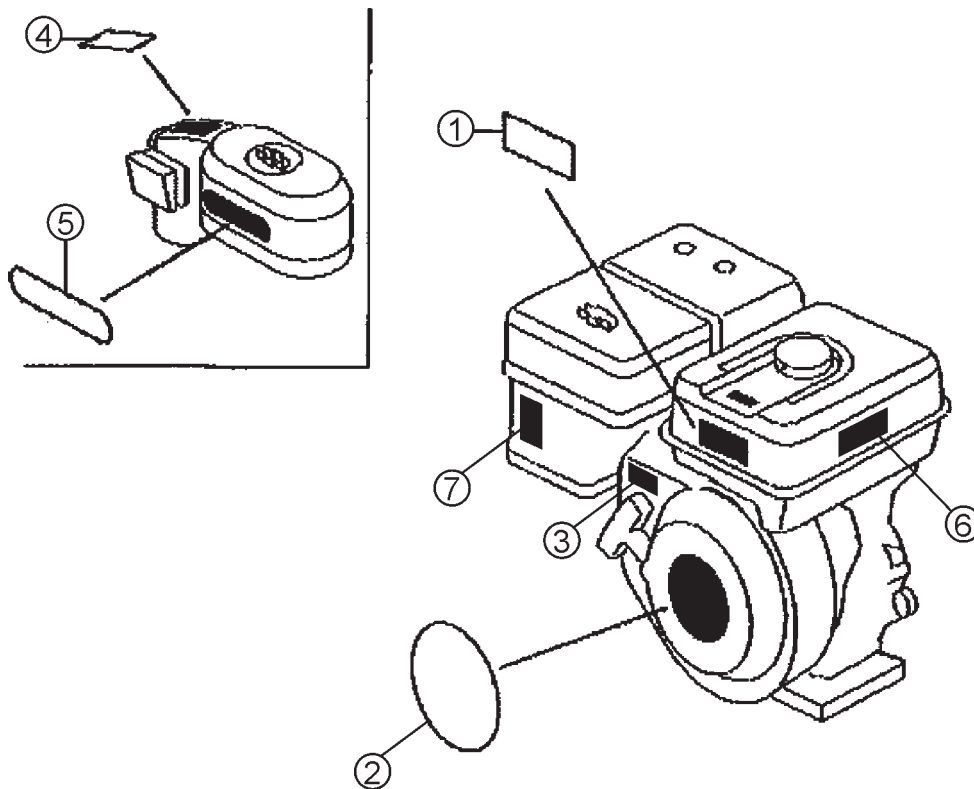

# HONDA GX390K1QWT2/GX390U1QWT2 ENG. — LABELS ASSY.

## LABELS ASSY.

<u>NO.</u>	<u>PART NO.</u>	<u>PART NAME</u>	<u>QTY.</u>	<u>REMARKS</u>
1✖	87522ZH9010	LABEL, CAUTION(ENGLISH ETC.)	1	
1◇	87516ZH7000	MARK OPERATOR CAUTION	1	
1◇	87516ZH7810	MARK OPERATOR PICTOGRAPH (OPTION)	1	
2✖	87521ZF6W02	EMBLEM (GX390 HONDA 13.0)	1	
2◇	87521ZF6W03	EMBLEM (GX390 HONDA 13.0) .....	1	S/N 1398206 AND BELOW
2◇	87521ZF6W04	EMBLEM (GX390 HONDA 13.0) .....	1	S/N 1398207 AND ABOVE
3◇	87532ZH7000	MARK, THROTTLE INDICATION	1	
4	87534ZE1841	LABEL, AIR CLEANER CAUTION	1	
5◇	87535ZE1841	MARK, AIR CLEANER SALES POINT	1	
6✖	87532ZH8810	MARK, OIL ALERT (E)	1	
7✖	87528ZE2810	MARK, CHOKE (EXTERNAL)	1	

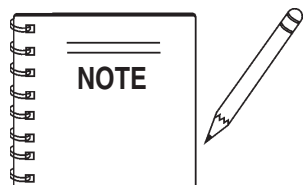

- ✖ GX390K1QWT2: Model S/N DECEMBER 2005 AND BELOW
- ◇ GX390U1QWT2: Model S/N JANUARY 2006 AND ABOVE