

PARTS MANUAL

STOW

A DIVISION OF MULTQUIP INC.

STAY-LEVEL HANDLEBAR SERIES MODELS

CS706016

CS706020

CS706026

CS706030

CS706036

PAVEMENT SAW (DEUTZ BF3L2011 DIESEL ENGINE)

Revision #7 (06/06/08)

THIS MANUAL MUST ACCOMPANY THE EQUIPMENT AT ALL TIMES.

P/N 37560

CS7060 SERIES SAWS

Proposition 65 Warning 2

Silicosis/Respiratory Warnings 3

Table of Contents 4

Parts Ordering Procedures 5

Explanation of Code in Remarks Column 6

Suggested Spare Parts 7

Nameplates and Decals 8-9

Control Panel Decals 10-11

Electrical Control Assembly 12-13

Console Mounts Assembly 14-15

Rear Console Access Panel Assembly 16-17

Light Connector/Dash Access Assembly 18-19

Belt and Engine Guards Assembly 20-21

Depth Indicator/Stop Switch Assy. (Old Style) 22-23

Depth Indicator/Stop Switch Assy. (New Style) 24-25

F-N-R Assembly 26-27

Fuel Assembly 28-29

Battery Assembly 30-31

Stay-Level Handlebars Assembly 32-33

Handlebar Boot Assembly 34-35

Water System Assembly 36-37

Engine Assembly 38-39

Throttle Control Assembly 40-41

Engine Mounts Assembly 42-43

Air Cleaner Assembly 44-45

Muffler Assembly 46-47

Lift Bail Assembly 48-49

Platform Guards/Rear Pointer Assembly 50-51

Wheel Drive Assembly 52-53

Front Axle Assembly 54-55

Hydraulic System Assembly 56-57

Engine Pivot Cylinder Assembly 58-59

Hydraulic Hoses Assembly 60-61

Hydraulic Fittings and Clamps Assembly 62-63

Front Pointer Assembly 64-65

Belt Drive Assembly 66-69

Drive Pulley Assembly 70-71

Bladeshaft Assembly 72-73

16", 20", 26" Bladeguard Assembly 74-75

30", 36" Bladeguard Assembly 76-77

Optional Weight Kit Assembly 78-79

Terms and Conditions of Sale — Parts 80

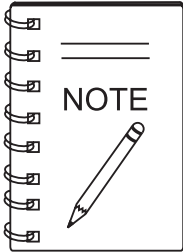

Specifications are subject to change without notice.

SUGGESTED SPARE PARTS

SS7060 SANDERS SAW

1 TO 3 UNITS WITH DEUTZ TURBO DIESEL ENGINE

Qty.	P/N	Description
1	37094	SWITCH, TOGGLE F-N-R
1	37203	SWITCH, ROLLER PLUNGER
2	406000	SWITCH, ROCKER
2	37132	FRONT WHEEL ASSEMBLY
2	37095	REAR WHEEL
1	29509	CAP, FUEL TANK
2	560017	GRIPS, HANDLEBAR
1	H9406	BULB, GE H9406
1	15503	KNOB, COMFORT
1	37311	BALL VALVE, WATER SYSTEM
2	570005	CLAMP, MUFFLER
2	37048	SPRING, WHEEL DRIVE
2	582012	BUSHING, QD
2	915316	SCREW, 5/8 - 11 X 3 LH GR8
2	915315	SCREW, 5/8 - 11 X 3 GR8
1	574003	ROPE, POINTER
1	37212	THROTTLE ASSEMBLY
2	200019	MUDFLAP, BLADEGUARD

ENGINE PARTS FOR DEUTZ TURBO DIESEL ENGINE

2	1174416	OIL FILTER, DEUTZ BF3L2012
2	304010	FUEL FILTER, DEUTZ BF3L2011
2	P772579	PRIMARY AIR FILTER ELEMENT
2	P775300	SAFETY AIR FILTER, DEUTZ BF3L2014
2	21004-003	FAN BELT, AX-35
2	520007	DRIVE BELT, 5G 3VX-530
1	406017	IGNITION SWITCH, W/KEY
2	406017-1	KEY, IGNITION
2	306006	FILTER, TRANSMISSION

FOR SAWS WITH 16", 20", AND 26" BLADEGUARDS

2	37168	FLANGE, INNER 5.0"
2	37169	FLANGE ASSEMBLY, OUTER 5.0"
2	926790	PIN, DOWEL
2	362000	HOSE, WATER #6LP (16" BLADEGUARD)
2	362005	HOSE, WATER #6LP (20" BLADEGUARD)
2	362006	HOSE, WATER #6LP (26" BLADEGUARD)

FOR SAWS WITH 30" AND 36" BLADEGUARDS

2	37177	FLANGE, INNER 6.0"
2	37176	FLANGE ASSEMBLY, OUTER 6.0"
2	926790	PIN, DOWEL
2	362007	HOSE, WATER #6LP (30" BLADEGUARD)
2	362008	HOSE, WATER #6LP (36" BLADEGUARD)



Part numbers on this Suggested Spare Parts List may supercede/replace the P/N's shown in the test pages of this manual.

NAMEPLATES AND DECALS

NAMEPLATES AND DECALS

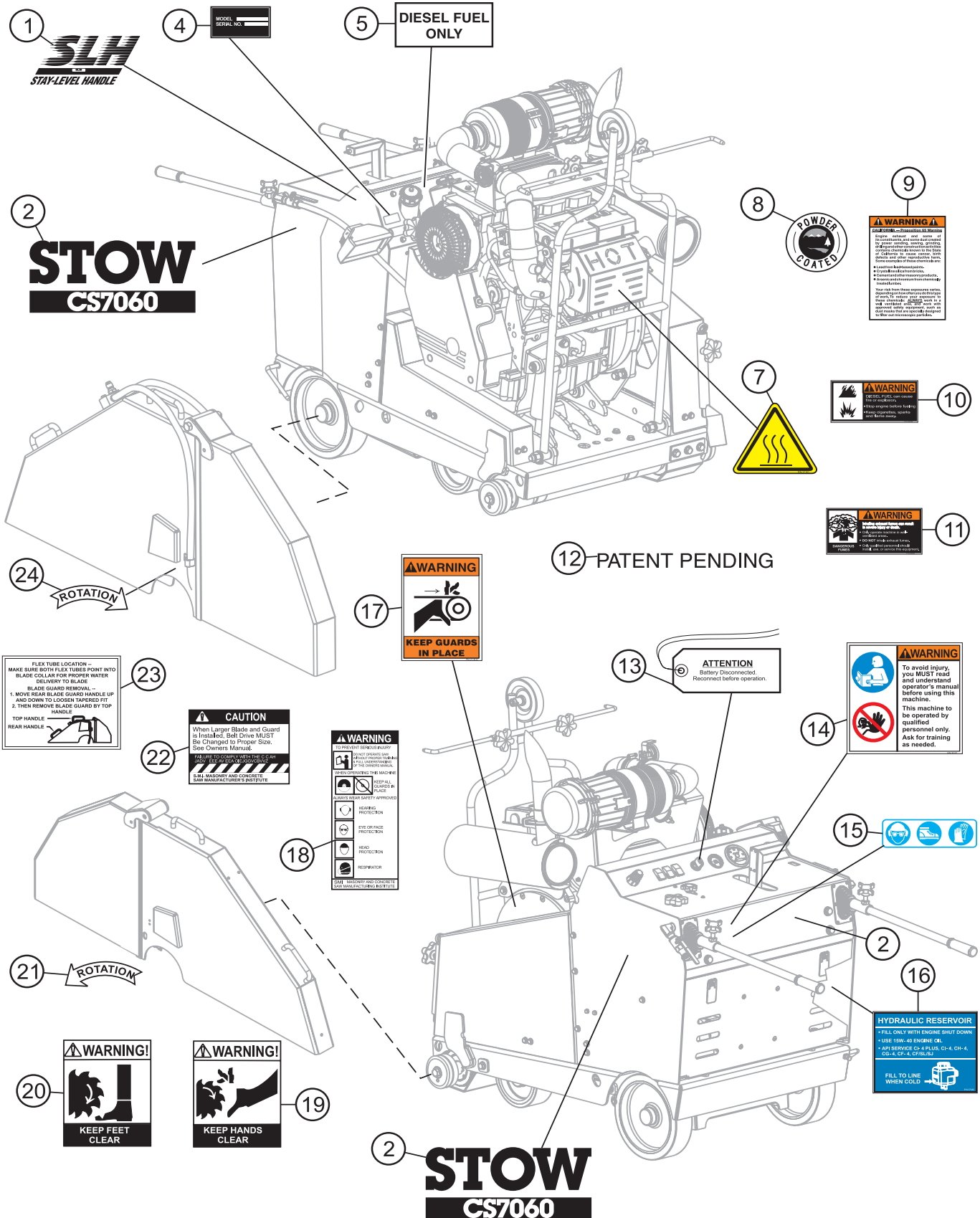

NAMEPLATES AND DECALS

NAMEPLATES AND DECALS

<u>NO.</u>	<u>PART NO.</u>	<u>PART NAME</u>	<u>QTY.</u>	<u>REMARKS</u>
1	37362	DECAL, STAY LEVEL HANDLE WHITE	2	
2	20936	DECAL, MQ MULTQUIP 5.93 X 7.45	3	
3	37365	DECAL, MQ PS7060	2	
4		SERIAL TAG	1	CONTACT PARTS DEPT.
5	M600002	DECAL, DIESEL FUEL ONLY	1	
7	37161	DECAL, HOT ISO HI-TEMPERATURE	1	SAFETY ITEM
8	13118	DECAL, POWDER COATED	1	
9	20525	DECAL, WARNING "PROP 65" 3.25 X 4.25	1	SAFETY ITEM
10	36092	DECAL, WARNING DIESEL FUEL 3.5 X 1.75	1	SAFETY ITEM
11	36090	DECAL, WARNING VENTILATION 2 X 4	1	SAFETY ITEM
12	11912	DECAL, PATENT PENDING	1	
13	25282	DECAL, ATTENTION BATTERY DISCONNECTED	1	
14	35137	DECAL, WARNING READ MANUAL	1	SAFETY ITEM
15	36099	DECAL, PROTECTIVE CLOTHING ISO BLUE	1	SAFETY ITEM
16	37540	DECAL, HYDRAULIC RESERVOIR	1	
17	21302	DECAL, WARNING KEEP GUARDS IN PLACE	2	SAFETY ITEM
18	22122-001	DECAL, WARNING RX-W	2	SAFETY ITEM
19	25249-001	DECAL, WARNING KEEP HANDS CLEAR	2	SAFETY ITEM
20	25250-001	DECAL, WARNING KEEP FEET CLEAR	2	SAFETY ITEM
21	25678	DECAL, BLADE ROTATION CCW	1	SAFETY ITEM
22	23330-001	DECAL, CAUTION BELT DRIVE	2	
23	606004	DECAL, GUARD REMOVAL	2	SAFETY ITEM
24	25491	DECAL, BLADE ROTATION CW	1	
25	11092	DECAL, CE	1	

CONTROL PANEL DECALS

CONTROL PANEL DECALS

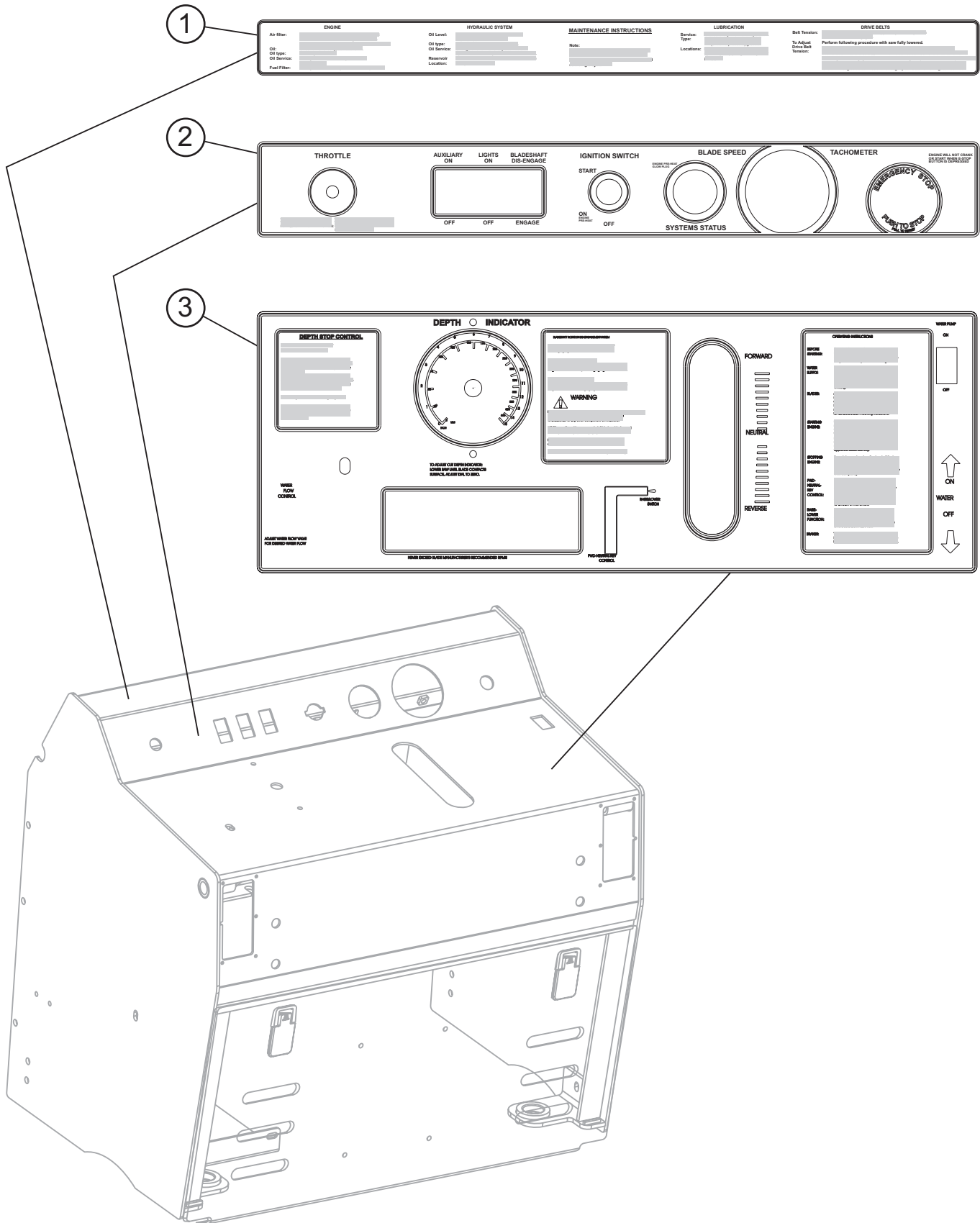

CONTROL PANEL DECALS

CONTROL PANEL DECALS

<u>NO.</u>	<u>PART NO.</u>	<u>PART NAME</u>	<u>QTY.</u>	<u>REMARKS</u>
1	37361	DECAL, MAINTENANCE, 7000 SERIES	1	
2	37354	DECAL, INSTRUMENT PANEL, 7000 SERIES	1	
3	37353	DECAL, OPERATION CONSOLE PANEL	1	

ELECTRICAL CONTROL ASSY.

ELECTRICAL CONTROL ASSY.

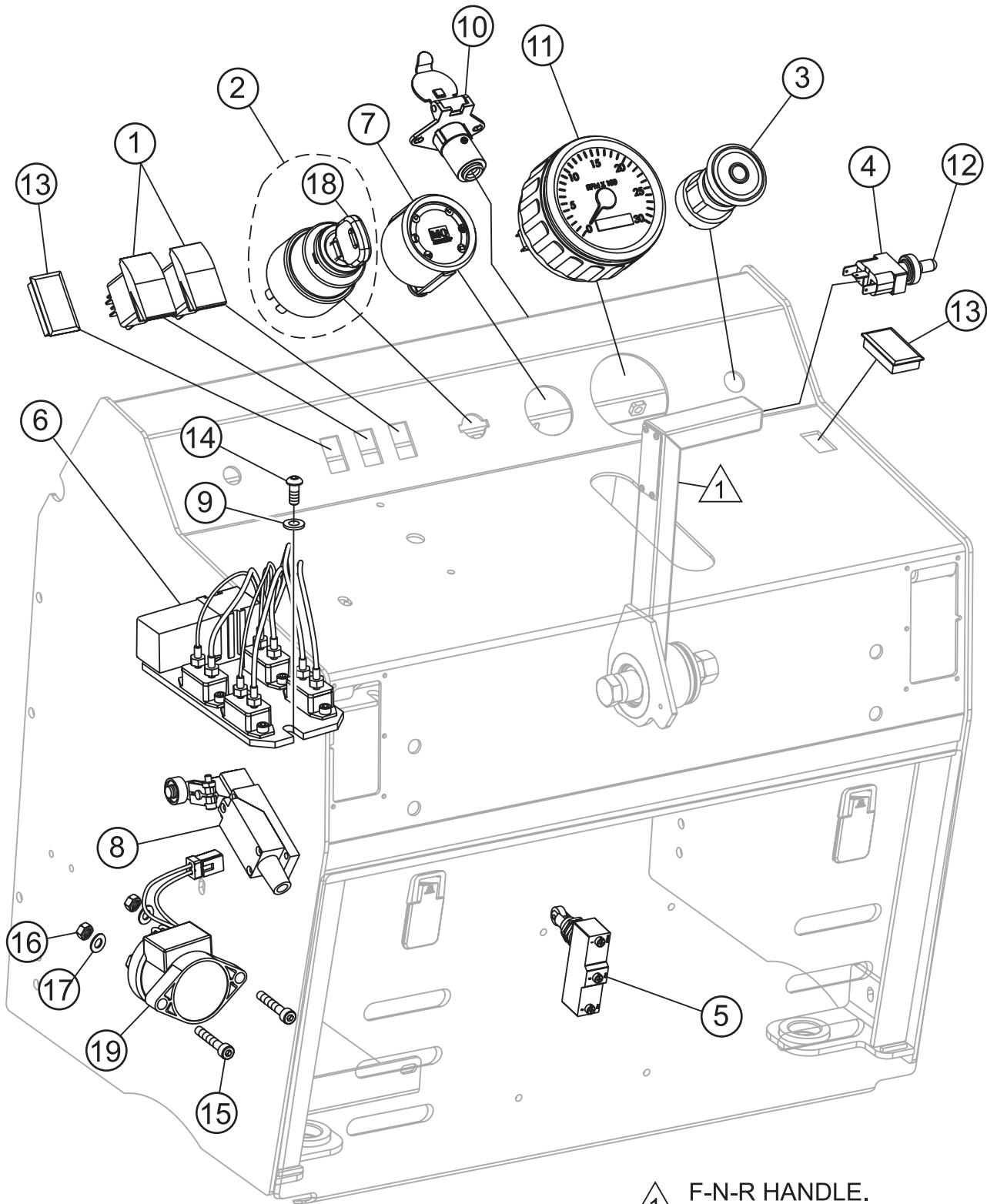

△ 1 F-N-R HANDLE.
SEE F-N-R ASSY.

ELECTRICAL CONTROL ASSY.

ELECTRICAL CONTROL ASSY.

<u>NO.</u>	<u>PART NO.</u>	<u>PART NAME</u>	<u>QTY.</u>	<u>REMARKS</u>
1	406000	SWITCH, ROCKER CH# M-58031-01	2	
2	406017	IGNITION SWITCH, WITH KEYS	1	INCLUDES ITEMS W/*
3	37198	EMERGENCY STOP SWITCH	1	SAFETY ITEM
4	37094	SWITCH, TOGGLE SPDT MOMENTARY ON-ON	1	
5	37203	SWITCH, SNAP ACTION ROLLER PLUNGER	1	
6	37490	HARNESS, RELAYS AND CIRCUIT BREAKERS	1	
7	406021	INDICATOR, ENGINE	1	
8	37243	SWITCH, ROLLER ARM	1	
9	933240	WASHER, FLAT SAE 1/4 GRD 9 YZ	3	
10	405000	CONNECTOR, 4-WAY SOCKET	1	
11	37368	TACHOMETER, ELECTRIC 0-3000 RPM	1	
12	8381	BOOT, TOGGLE SWITCH	1	
13	406020	BLANK, ROCKER SWITCH	2	
14	973752	SCREW, BHHC 1/4 - 20 X 5/8 SS	3	
15	37325	SCREW, SHC M5 - 0.8 X 30MM	2	
16	37324	NUT, NYLOC M5 - 0.8	2	
17	28922-058	WASHER, M5	2	
18*	406017-1	KEY, IGNITION	1	
19	25628	SOLENOID, LIFT PUMP	1	

CONSOLE MOUNTS ASSY.

CONSOLE MOUNTS ASSY.

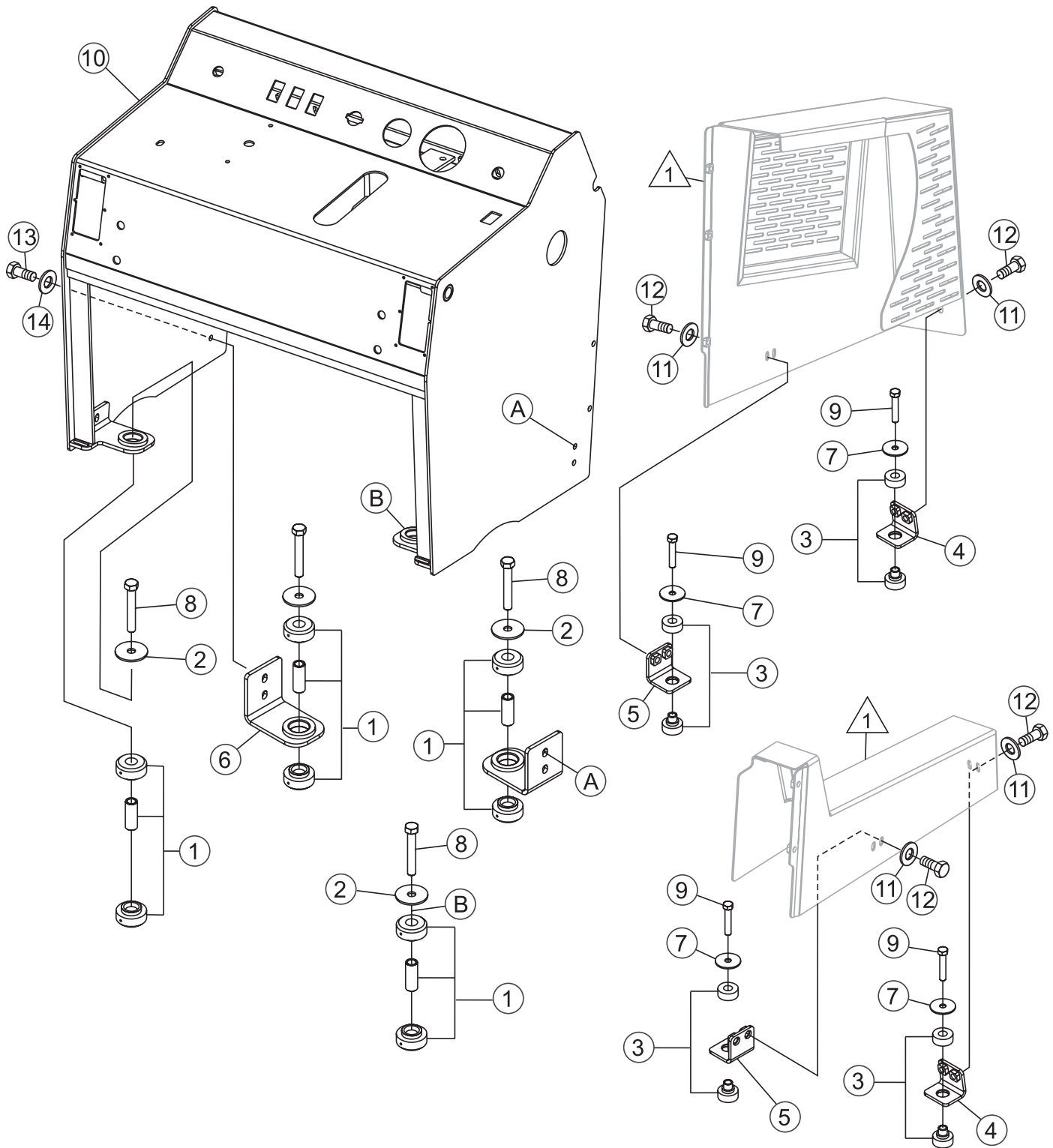

1 SEE BELT AND ENGINE GUARDS ASSY.

CONSOLE MOUNTS ASSY.

CONSOLE MOUNTS ASSY.

<u>NO.</u>	<u>PART NO.</u>	<u>PART NAME</u>	<u>QTY.</u>	<u>REMARKS</u>
1	20742	ISOLATOR, RB2 RING/BUSHING	4	
2	20743	WASHER, ISO SNUB KROFUND DYN 148099-18	4	
3	575001	RUBBER ISOLATOR, TPC# 60166-1	4	
4	37231-353	MOUNT, ISOLATOR FRONT	2	
5	37233-353	MOUNT, ISOLATOR SIDE	2	
6	37227-353	MOUNT, CONSOLE ISOLATOR FRONT	2	
7	12832	WASHER, SNUBBING	4	
8	06503-026	SCREW, HHC 1/2 - 13 X 3-1/4	4	
9	1665	SCREW, HHC 3/8 - 16 X 2	4	
10	37116-353	CONSOLE W/A	1	
11	933242	WASHER, FLAT SAE 3/9 GRD 9 Y	8	
12	0205	SCREW, HHC 3/8-16 X 1	8	
13	TBD	SCREW	4	
14	TBD	WASHER	4	

REAR CONSOLE ACCESS PANEL ASSY.

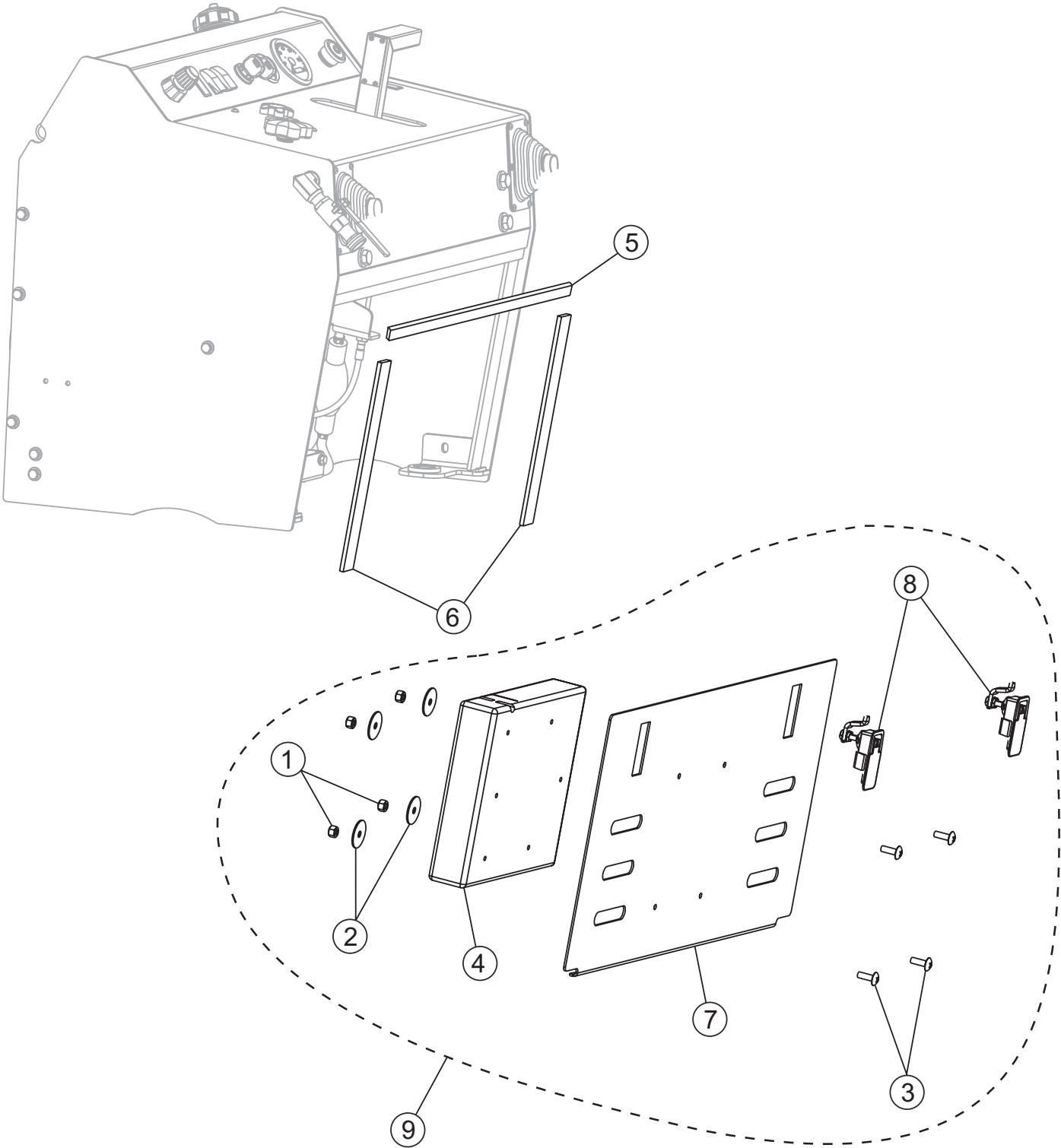

REAR CONSOLE ACCESS PANEL ASSY.

REAR CONSOLE ACCESS PANEL ASSY.

<u>NO.</u>	<u>PART NO.</u>	<u>PART NAME</u>	<u>QTY.</u>	<u>REMARKS</u>
1*	10024	NUT, NYLOC 1/4 X 20	4	
2*	10930	WASHER, FENDER 1/4 X 1-1/4	4	
3*	12287	SCREW, THP 1/4 - 20 X 3/4 SS	4	
4*	29057	DOCUMENT BOX	1	
5	37219	STRIP, BACKING PLATE SAW CONSOLE	1	
6	37220	STRIP, VERTICAL SAW CONSOLE	2	
7*	37254-353	PANEL, REAR SAW ACCESS	1	
8*	560020	LATCH, REAR SAW ACCESS PANEL	2	
9	37253	PANEL ASSEMBLY, REAR SAW ACCESS	1	INCLUDES ITEMS W/*

LIGHT CONNECTOR/DASH ACCESS ASSY.

LIGHT CONNECTOR/DASH ACCESS ASSY.

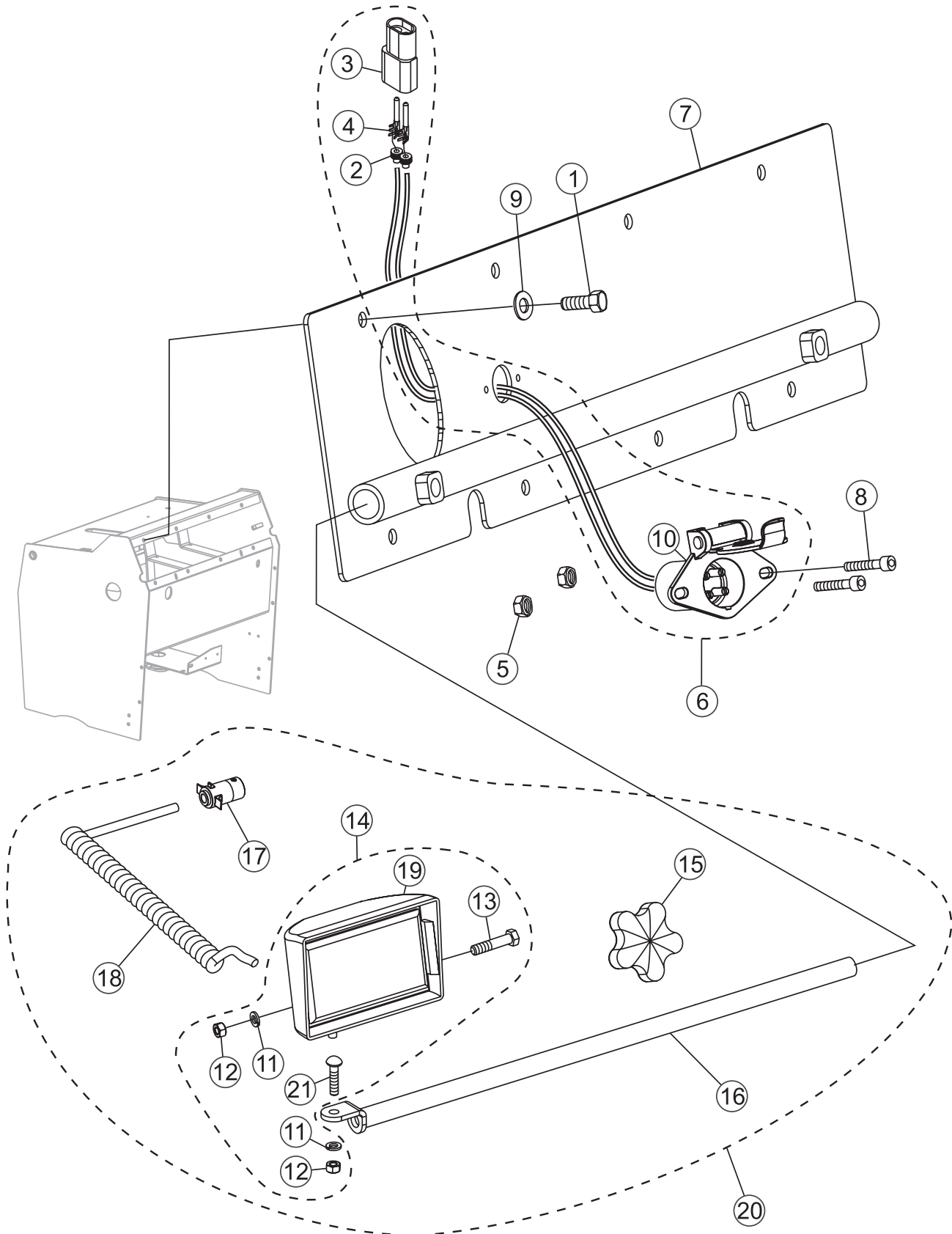

LIGHT CONNECTOR/DASH ACCESS ASSY.

LIGHT CONNECTOR/DASH ACCESS ASSY.

<u>NO.</u>	<u>PART NO.</u>	<u>PART NAME</u>	<u>QTY.</u>	<u>REMARKS</u>
1	0655	SCREW, HHC 5/16 - 18 X 3/4	8	
2*	12171	SEAL, WEATHERPACK 16-18 GA, GREEN	2	
3*	12176	CONNECTOR, WEATHERPACK 2 PIN MALE	1	
4*	12179	TERMINAL, WEATHERPACK MALE 14-16 GA	2	
5	13287	NUT, NYLOC 8-32	2	
6	25865	HARNESS, LIGHT KIT	1	INCLUDES ITEMS W/*
7	37234-353	COVER W/A, CONSOLE DASH ACCESS	1	
8	923114	SCREW, SHC 8-32 X 1/2	2	
9	933241	WASHER, FLAT SAE 5/16 GRD 9YZ	8	
10*	405000	CONNECTOR, 4-WAY SOCKET CHROME	1	
11+#	0161 C	WASHER, LOCK 5/16 MED	2	
12+#	0161 D	NUT, HEX 5/16 - 18	2	
13+#	0300 A	SCREW, HHC 5/16 - 18 X 2	1	
14+	2532	LIGHT ASSEMBLY	1	INCLUDES ITEMS W/#
15+	15503	KNOB, COMFORT GRIP STAR	1	
16+	120206	LIGHT BAR	1	
17+	405001	CONNECTOR PLUG, 4-PIN FEMALE	1	
18+	405002	CORD, LIGHT EXTENDABLE	1	
19+#	H9406	BULB, GE H9406	1	
20	M18004	LIGHT KIT, SAW	1	INCLUDES ITEMS W/+
21#	11963	BOLT, CARRIAGE 5/16 - 18 X 1	1	

BELT AND ENGINE GUARDS ASSY.

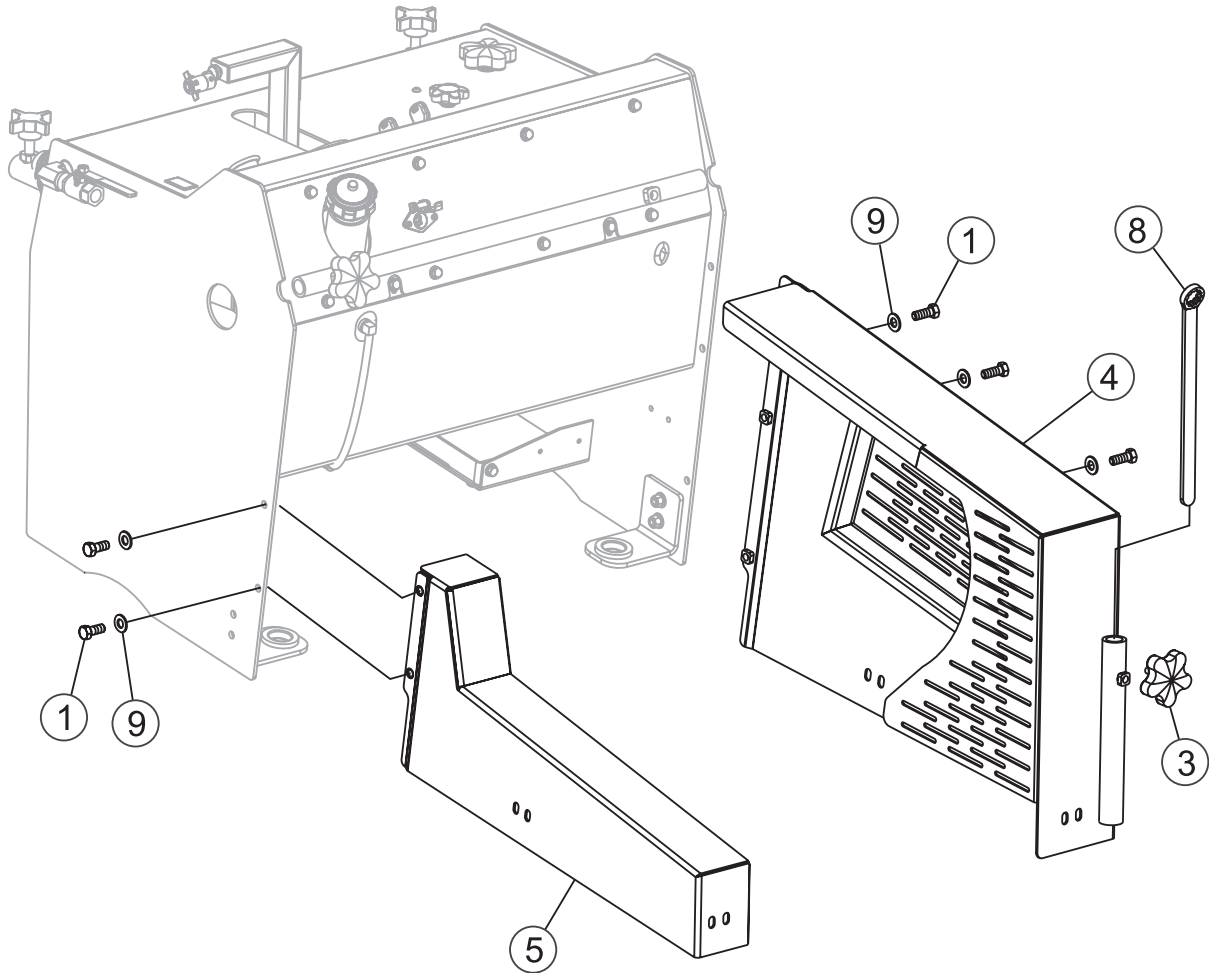

BELT AND ENGINE GUARDS ASSY.

BELT AND ENGINE GUARDS ASSY.

<u>NO.</u>	<u>PART NO.</u>	<u>PART NAME</u>	<u>QTY.</u>	<u>REMARKS</u>
1	0166	SCREW, HHC 3/8 - 16 X 7/8	5	
3	15503	KNOB, COMFORT	1	
4	37202-353	GUARD, BELT DRIVE	1	SAFETY ITEM
5	37209-353	GUARD, ENGINE	1	SAFETY ITEM
8	584011	WRENCH, 15/16 BLADE CLOSED END	1	
9	933242	WASHER, FLAT SAE 3/8 GRD 9 YZ	5	

DEPTH INDICATOR/STOP SWITCH ASSY. (OLD STYLE)

DEPTH INDICATOR/STOP SWITCH ASSY. (OLD STYLE)

<u>NO.</u>	<u>PART NO.</u>	<u>PART NAME</u>	<u>QTY.</u>	<u>REMARKS</u>
1	10024	NUT, NYLOC 1/4 - 20	2	
2	37155	PULLEY, CABLE .75 OD	1	
3	37235	BASE, SAW DEPTH INDICATOR	1	
4	37240	PULLEY, CABLE .75 OD	2	
5	37241	SHAFT, DEPTH INDICATOR	1	
6	37332	RING, 3/16 E-STYLE EXTERNAL	2	
7	37401	SCREW, SH SHLDR 1/2-20, 5/16 OD X 1/4 L	1	
8	37504	CABLE, NYLON COAT SS .049	1	
9	110031	POINTER, CONCRETE SAW DEPTH	1	
10	460019	FLANGE, BEARING 0.25 ID X 0.75 OD	1	
11	560025	KNOB, SAW DEPTH INDICATOR	1	
12	565005	SPRING, EXTENSION	1	
13	583059	SHIM, 0.375 OD X 0.25 ID X .020 THK	5	
14	584025	STUD, 1/4 - 20 X 1-3/4 NO PLT	1	
15	933240	WASHER, FLAT SAE 1/4 GRD 9 YZ	1	
16	973752	SCREW, BHSC 1/4 - 20 X 5/8 SS	2	
17	37248	MOUNT, SWITCH PIVOT PLATE	1	
18	37246	NUT, SWIVEL DEPTH STOP	1	
19	37247	KNOB, DEPTH STOP CONTROL	1	
20	37249	COLLAR, SHAFT THREADED 3/8 - 16	1	
21	37250	WASHER, BELLEVIEW .317 X .625	2	
22	19470	WASHER, FLAT 5/16 USS	2	
23	933242	WASHER, FLAT SAE 3/8 GRD 9 YZ	1	
24	5283	NUT, NYLOC 5/16 - 18	2	
25	10133	NUT, NYLOC 3/8 - 16	1	
26	37251	WASHER, BELLEVIEW .389 X .750	2	
27	37375	STUD, 3/8 - 16 X 4	1	
28	4001	WASHER, FLAT USS 3/8 PLD	3	



PARTS ON THIS PAGE ARE NO LONGER AVAILABLE. SEE DEPTH INDICATOR/STOP SWITCH ASSY. (NEW STYLE)

DEPTH INDICATOR/STOP SWITCH ASSY. (NEW STYLE)

DEPTH INDICATOR/STOP SWITCH ASSY. (NEW STYLE)

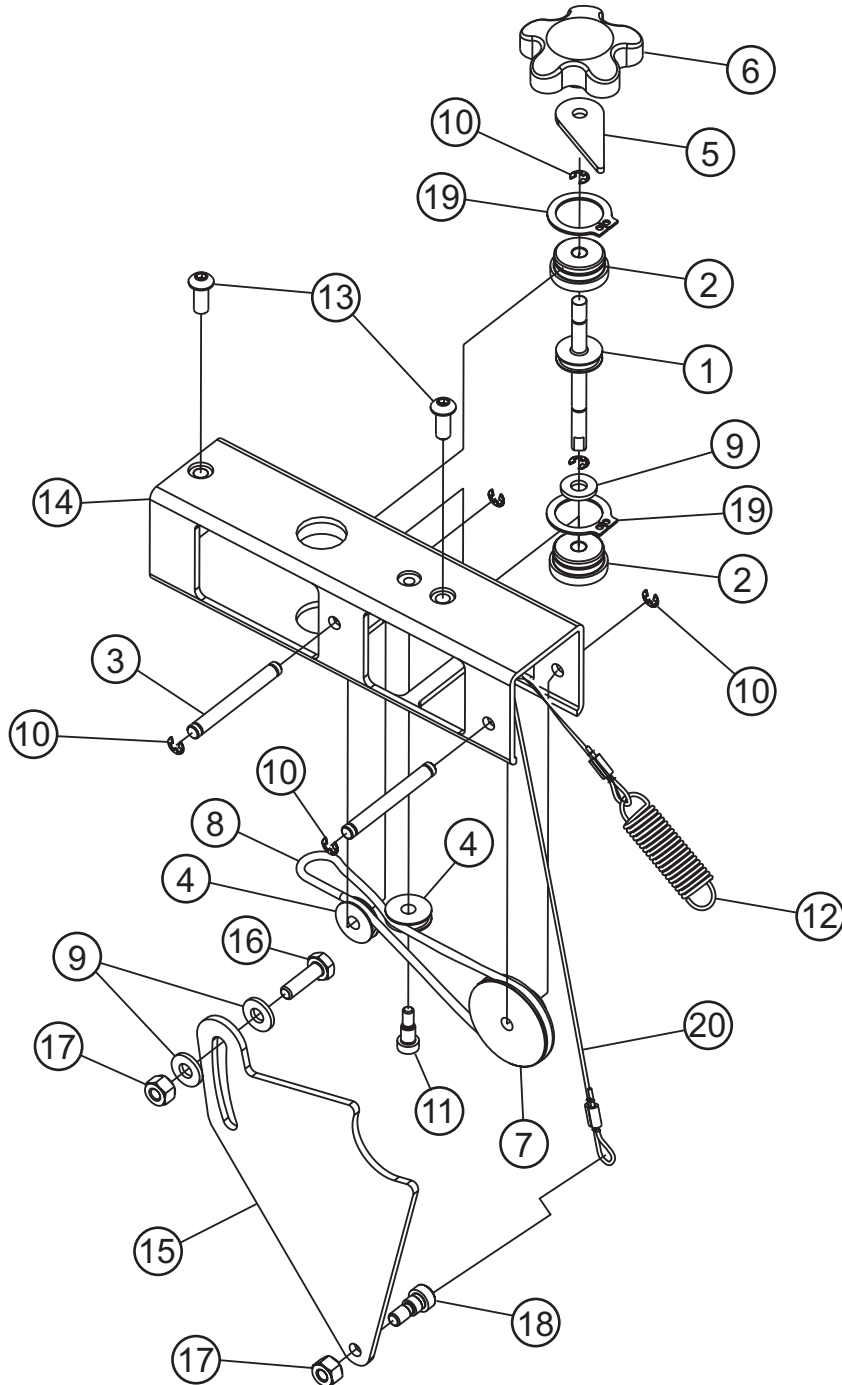

DEPTH INDICATOR/STOP SWITCH ASSY. (NEW STYLE)

DEPTH INDICATOR/STOP SWITCH ASSY. (NEW STYLE)

<u>NO.</u>	<u>PART NO.</u>	<u>PART NAME</u>	<u>QTY.</u>	<u>REMARKS</u>
1	37544	SHAFT, DEPTH INDICATOR	1	
2	37545	BUSHING, FLANGED	2	
3	37547	SHAFT, IDLER PULLEY	2	
4	37548	PULLEY, IDLER	2	
5	110031	POINTER, CONCRETE SAW DEPTH	1	
6	560025	KNOB, SAW DEPTH INDICATOR	1	
7	37549	PULLEY, DUAL GROOVE	1	
8	37550	BELT, INDICATOR DRIVE	1	
9	0948	WASHER, FLAT SAE 1/4	3	
10	37332	RING, 3/16 E-STYLE EXTERNAL	6	
11	926149	SCREW, SHDLR 1/4D X 5/16L, 10-24 SCKT HD	1	
12	37162	SPRING, EXTENSION	1	
13	973752	SCREW, BHSC 1/4 - 20 X 5/8 SS	2	
14	37551	HOUSING, DEPTH INDICATOR	1	
15	37557	BRACKET, CABLE INDICATOR	1	
16	2295	SCREW, HHC 1/4 - 20 X 7/8	1	
17	10024	NUT, NYLOC 1/4 - 20	2	
18	37401	SCREW, SH SHLDR 1/2-20, 5/16 OD X 1/4 L	1	
19	37679	RING, SNAP SH 87	2	
20	37678	CABLE ASSY., DEPTH INDICATOR	1	

F-N-R ASSY.

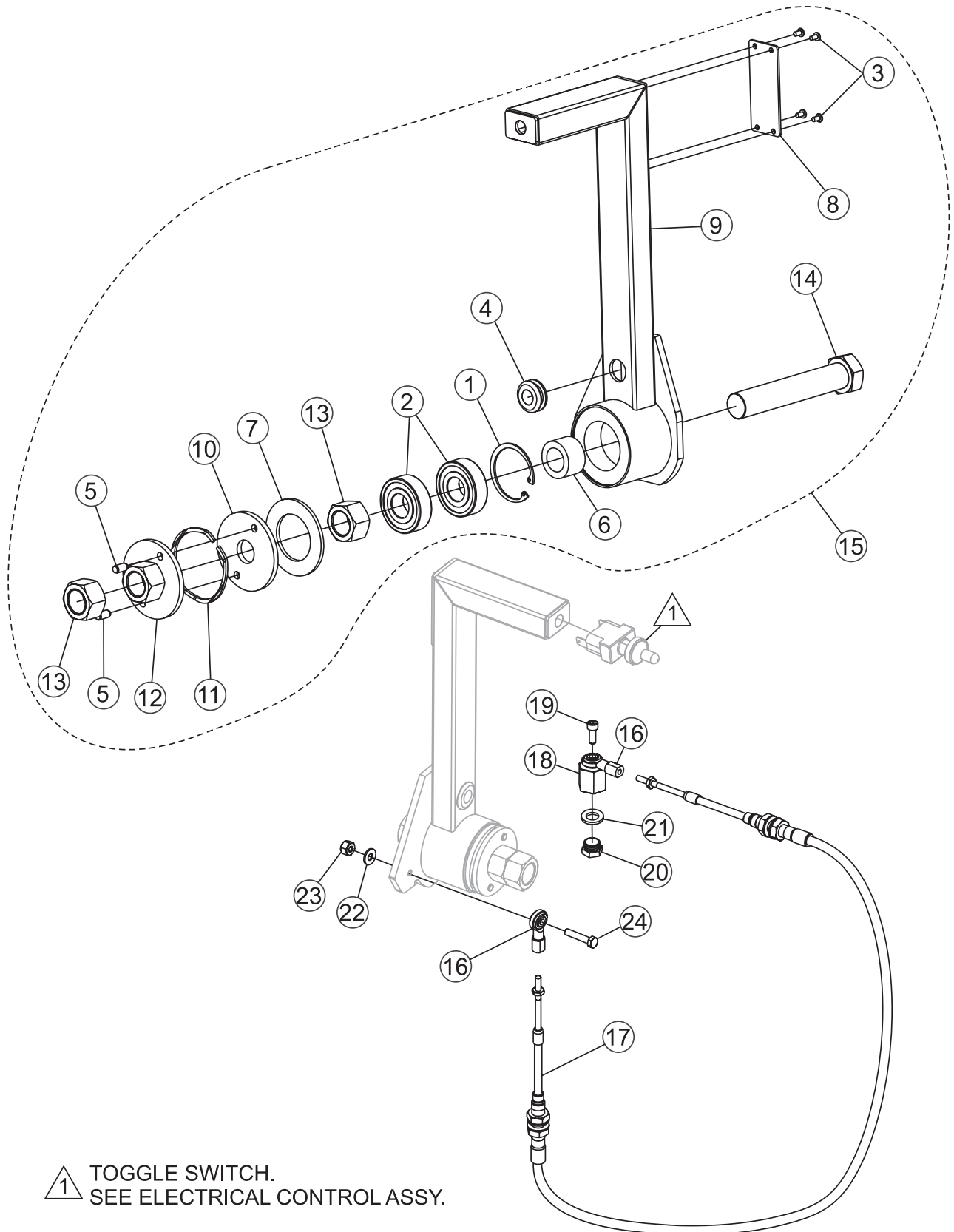

△ 1 TOGGLE SWITCH.
SEE ELECTRICAL CONTROL ASSY.

F-N-R ASSY.

<u>NO.</u>	<u>PART NO.</u>	<u>PART NAME</u>	<u>QTY.</u>	<u>REMARKS</u>
1*	576003	SNAP RING - HO-185	1	
2*	460021	BEARING, ROLLER # 6204 2RS	2	
3*	20842	SCREW, PAN HD 6-32 X 1/4	4	
4*	579072	GROMMET, 1/2" ID	1	
5*	926917	PIN, DOWEL 1/4 X 1/2	2	
6*	37015	SPACER, FNR PIVOT	1	
7*	37014	DISC, FNR FRICTION BRAKE	1	
8*	37013	PLATE, FNR ACCESS COVER	1	
9*	37022	WELDMENT, FNR HANDLE	1	
10*	37016	PLATE, FNR BRAKE	1	
11*	37091	SPRING, SMALLEY WAVO RW-0250	1	
12*	37024	WELDMENT, FNR SPRING PLATE	1	
13*	37025	NUT, HEX FINISH M20-2.5	2	
14*	37026	SCREW, HHC M20 X 2.5 X 120	1	
15	37021	FNR ASSEMBLY	1	INCLUDES ITEMS W/*
16	2153	ROD END	2	
17	37136	CABLE, PUSH PULL 56"	1	
18	37299	STANDOFF, PUMP CONTROL	1	
19	07469-004	SCREW, SHC 10-32 X 1/2	1	
20	4683	SCREW, HHC 5/16 - 18 X 5/8	1	
21	933241	WASHER, FLAT SAE 5/16 GRD 9 YZ	1	
22	2203	WASHER, FLAT #10	1	
23	10019	NUT, NYLOC 10-32	1	
24	3513	SCREW, HHC 10 - 32 X 1	1	

FUEL ASSY.

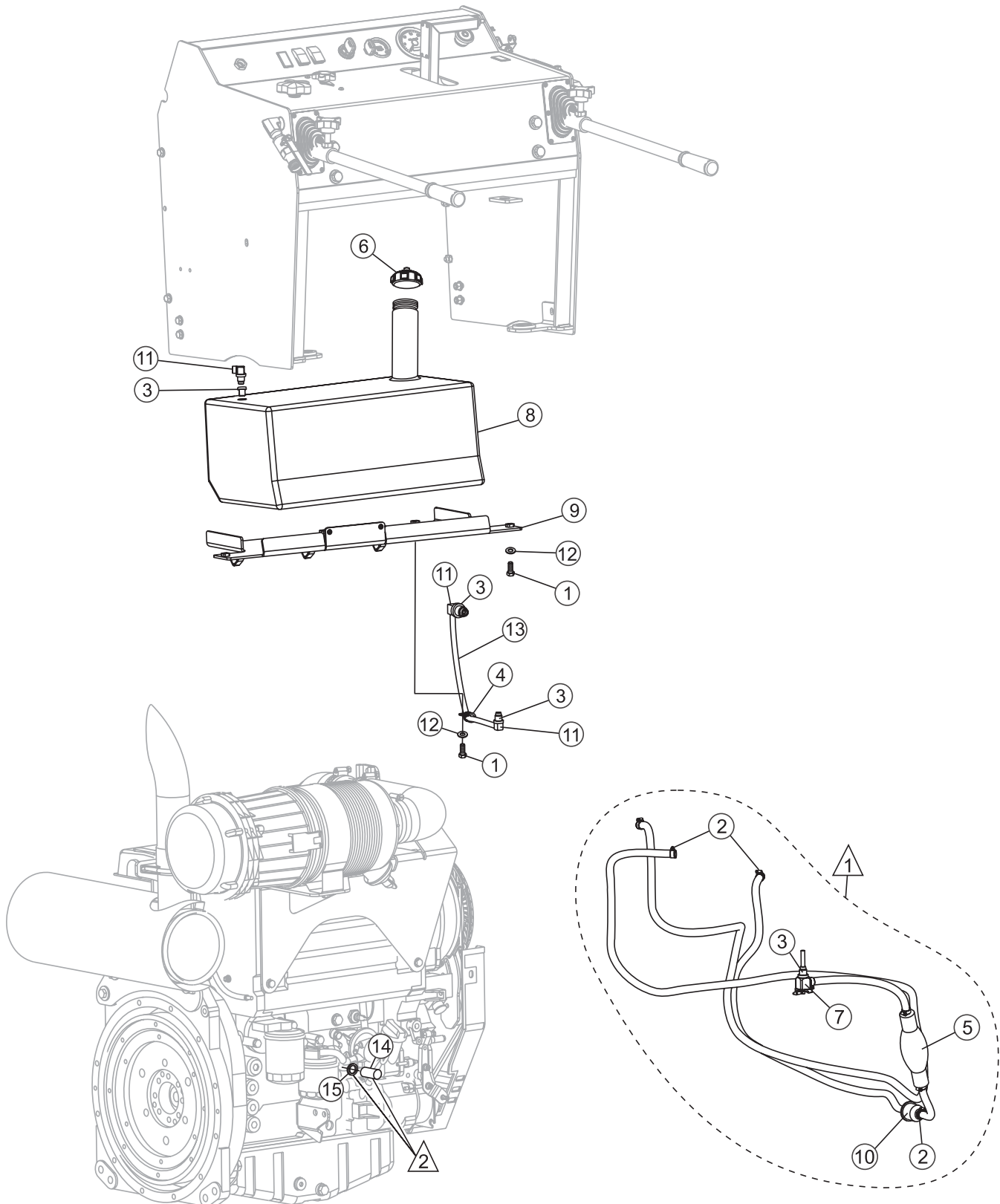

▲ 1 S/N ZC3700225 AND BELOW

▲ 2 S/N ZC3700226 AND ABOVE

FUEL ASSY.

<u>NO.</u>	<u>PART NO.</u>	<u>PART NAME</u>	<u>QTY.</u>	<u>REMARKS</u>
1	0205	SCREW, HHC 3/8 - 16 X 1.0	5	
2	19473	CLAMP, WORM HOSE 2"	8	S/N ZC3700225 AND BELOW
3	19633	BUSHING, RUBBER FUEL DAPCO	4	
4	35022	CLAMP, LOOP CUSHIONED #8	1	
5	29338	PRIMER BULB 5/16 HOSE BARB	1	S/N ZC3700225 AND BELOW
6	29509	CAP, FUEL TANK	1	
7	37128	BALL VALVE, 90 W/SCREEN #5	1	S/N ZC3700225 AND BELOW
8	37191	FUEL TANK	1	
9	37195-353	MOUNT, FUEL TANK	1	
10	37809	FILTER, FUEL DEUTZ IN-LINE	1	S/N ZC3700225 AND BELOW
11	368006	FITTING, FUEL 90 DEG	3	
12	933242	WASHER, FLAT SAE 3/8 GRD 9 YZ	5	
13	60058	HOSE, 1/4 X 3/8 PVC YELLOW	1.2	SOLD BY FOOT
14	2111897	HAND PUMP, INTEGRATED	1	S/N ZC3700226 AND ABOVE
15	1287773	O-RING SEAL	1	S/N ZC3700226 AND ABOVE

BATTERY ASSY.

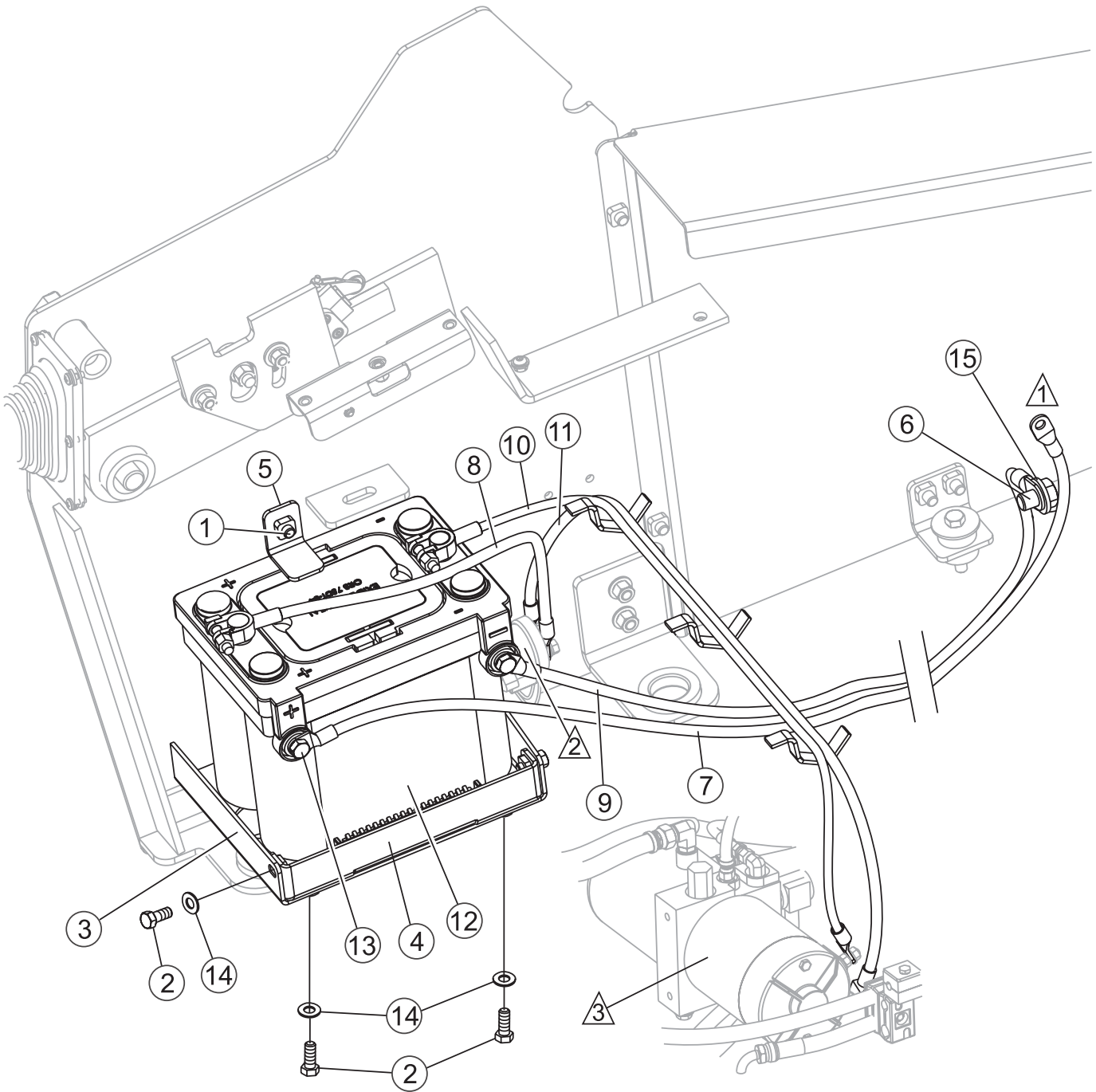

① TO ENGINE STARTER MOTOR

② LIFT PUMP SOLENOID (RELAY).
SEE ELECTRICAL CONTROL ASSY.

③ LIFT PUMP.
SEE HYDRAULIC SYSTEM ASSY.

BATTERY ASSY.

BATTERY ASSY.

<u>NO.</u>	<u>PART NO.</u>	<u>PART NAME</u>	<u>QTY.</u>	<u>REMARKS</u>
1	0166	SCREW, HHC 3/8 - 16 X 7/8	1	
2	0655	SCREW, HHC 5/16 - 18 X 3/4	4	
3	37088	BOX, BATTERY	1	
4	37098	RETAINER, BATTERY HOLD-DOWN	1	
5	37258-353	CLIP, BATTERY RETAINER	1	
6	37284	SCREW, HHC M14 - 2.0 X 20MM GRD 8.8 PLTD	1	
7	37326	CABLE, POSITIVE BATTERY STARTER	1	
8	37327	CABLE, POSITIVE BATT. SOLENOID LIFT PUMP	1	
9	37328	CABLE, NEGATIVE BATTERY ENGINE	1	
10	37329	CABLE, NEGATIVE BATTERY LIFT PUMP	1	
11	37355	CABLE, POSITIVE BATT. SOLENOID LIFT PUMP	1	
12	404006	BATTERY, EXIDE ORB75DT-84	1	
13	915101	SCREW, HHC 3/8 - 16 X 1/2 GRD 8	2	
14	933241	WASHER, FLAT SAE 5/16 GRD 9 YZ	4	
15	933245	WASHER, FLAT SAE 9/16 GRD 9 YZ	1	

STAY-LEVEL HANDLEBARS ASSY.

STAY-LEVEL HANDLEBARS ASSY.

<u>NO.</u>	<u>PART NO.</u>	<u>PART NAME</u>	<u>QTY.</u>	<u>REMARKS</u>
1	37085	BEARING, 1.25" TAP BASE	1	
2	37239	SHAFT, CROSSDRIVE SLH	1	
3	37119	RECEIVER, SLH HANDLEBAR LH	1	
4	37120	RECEIVER, SLH HANDLEBAR RH	1	
5	37125	BEARING, PLAIN 1.0625 ULTRASERT UC200	2	
6	560023	HANDLEBAR ASSY., CONCRETE SAW	2	INCLUDES ITEMS W/*
7	37174	LINK ASSY., SLH CONTROL COUPLER	1	INCLUDES ITEMS W/#
8	37139	SLH CONTROL LEVER	1	
9	16523	SCREW, HHC 3/4 - 10 X 1-1/2 GD 8	3	
10	933245	WASHER, FLAT SAE 9/16 GRD 9 YZ	4	
11	933247	WASHER, FLAT SAE 3/4 GRD 9 YZ	3	
12	37284	SCREW, HHC M14-2.0 X 20MM GRD 8.8 PLTD	4	
13	37312	RING, RETAINING WHM-106	2	
14	19977	KNOB, CLAMP 1/2 - 13 THREAD	2	
15#	37123	LINK, SLH CONTROL COUPLER LOWER	1	
16#	37173	LINK, SLH CONTROL COUPLER UPPER	1	
17#	37297	PLATE, SLH CLAMP	1	
18#	16526	SCREW, HHC 1/2 - 13 X 1-3/4 GRD 8	2	
19	4196	SCREW, HHC 3/8 - 16 X .75	2	
20#	933244	WASHER, FLAT SAE 1/2 GRD 9 YZ	2	
21	4001	WASHER, FLAT USS 3/8 PLD	2	
22	37133	PIN, SLH COUPLER PIVOT	2	
23*	560017	GRIP, HANDLEBAR	2	

HANDLEBAR BOOT ASSY.

HANDLEBAR BOOT ASSY.

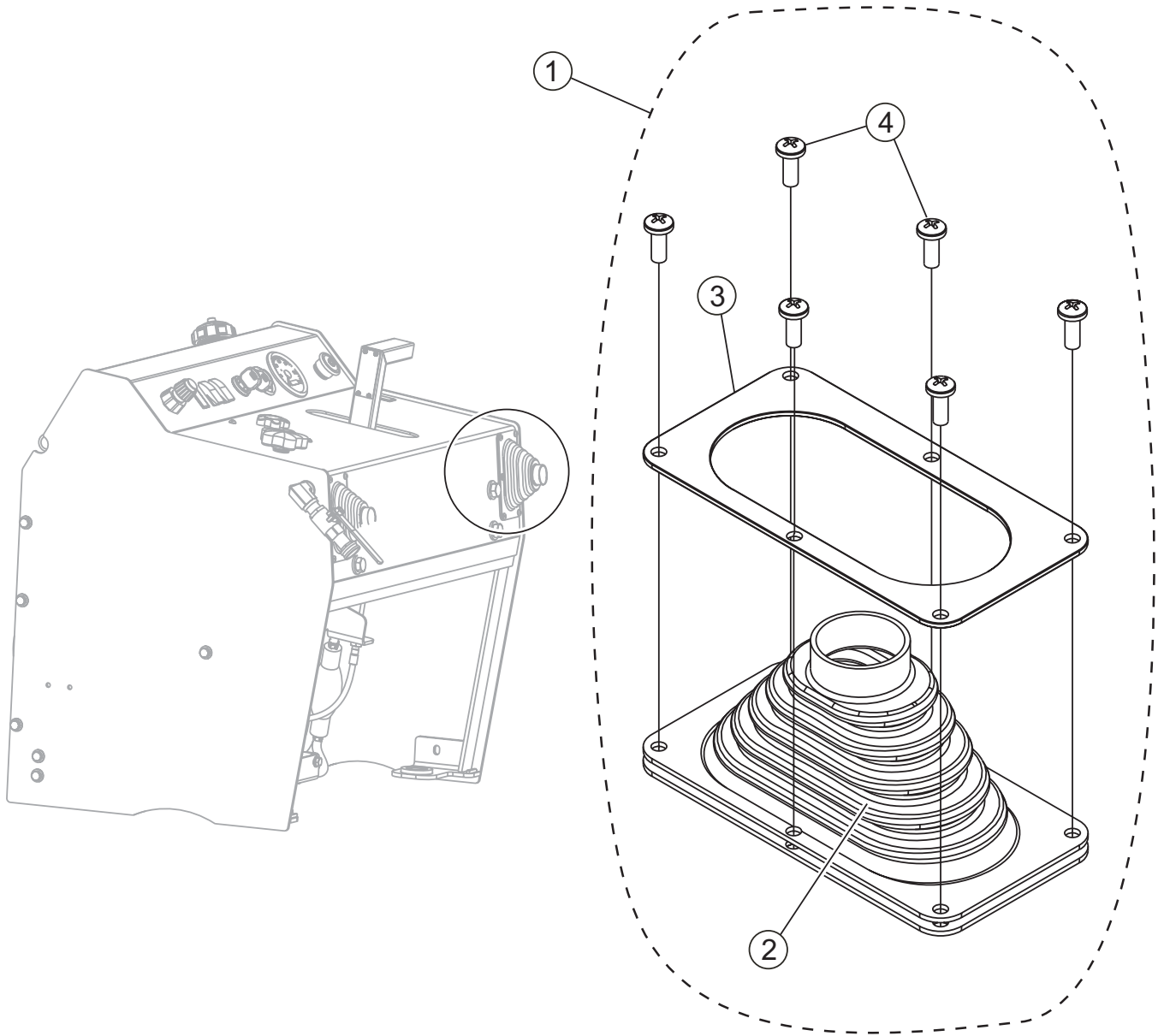

HANDLEBAR BOOT ASSY.

HANDLEBAR BOOT ASSY.

<u>NO.</u>	<u>PART NO.</u>	<u>PART NAME</u>	<u>QTY.</u>	<u>REMARKS</u>
1	37117	BOOT ASSY., HANDLEBAR	1	INCLUDES ITEMS W/*
2*	37105	BOOT, SLH HANDLEBAR	1	
3*	37061	PLATE, RETAINER	1	
4*	5065 B	SCREW, PHP 10 - 32 X 1/2	6	

WATER SYSTEM ASSY.

WATER SYSTEM ASSY.

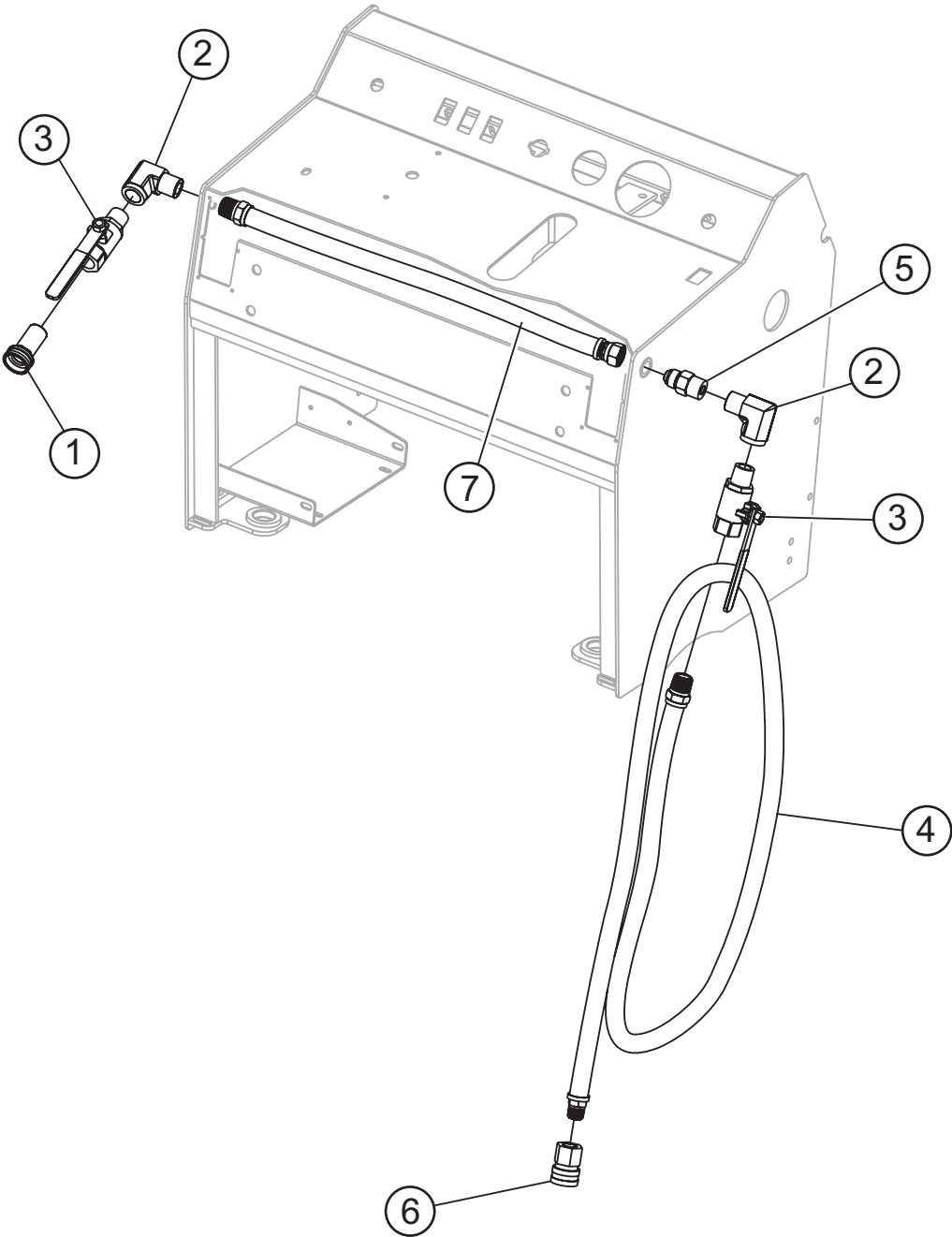

WATER SYSTEM ASSY.

WATER SYSTEM ASSY.

<u>NO.</u>	<u>PART NO.</u>	<u>PART NAME</u>	<u>QTY.</u>	<u>REMARKS</u>
1	25827	FITTING, BRASS (F) 3/4 GHT SWIVEL 1/2 MNPT	1	
2	37813	FITTING, 90 1/2MP - 3/8FP	2	
3	37311	BALL VALVE, BRASS 3/8 MNPT X FNPT	2	
4	37533	HOSE ASSEMBLY, WATER SYSTEM 76.5"	1	
5	37397	FITTING, 8MJ X 1/2 MP	1	
6	37532	FITTING, QC FEMALE	1	
7	37296	HOSE ASSEMBLY, CROSSOVER	1	

ENGINE ASSY.

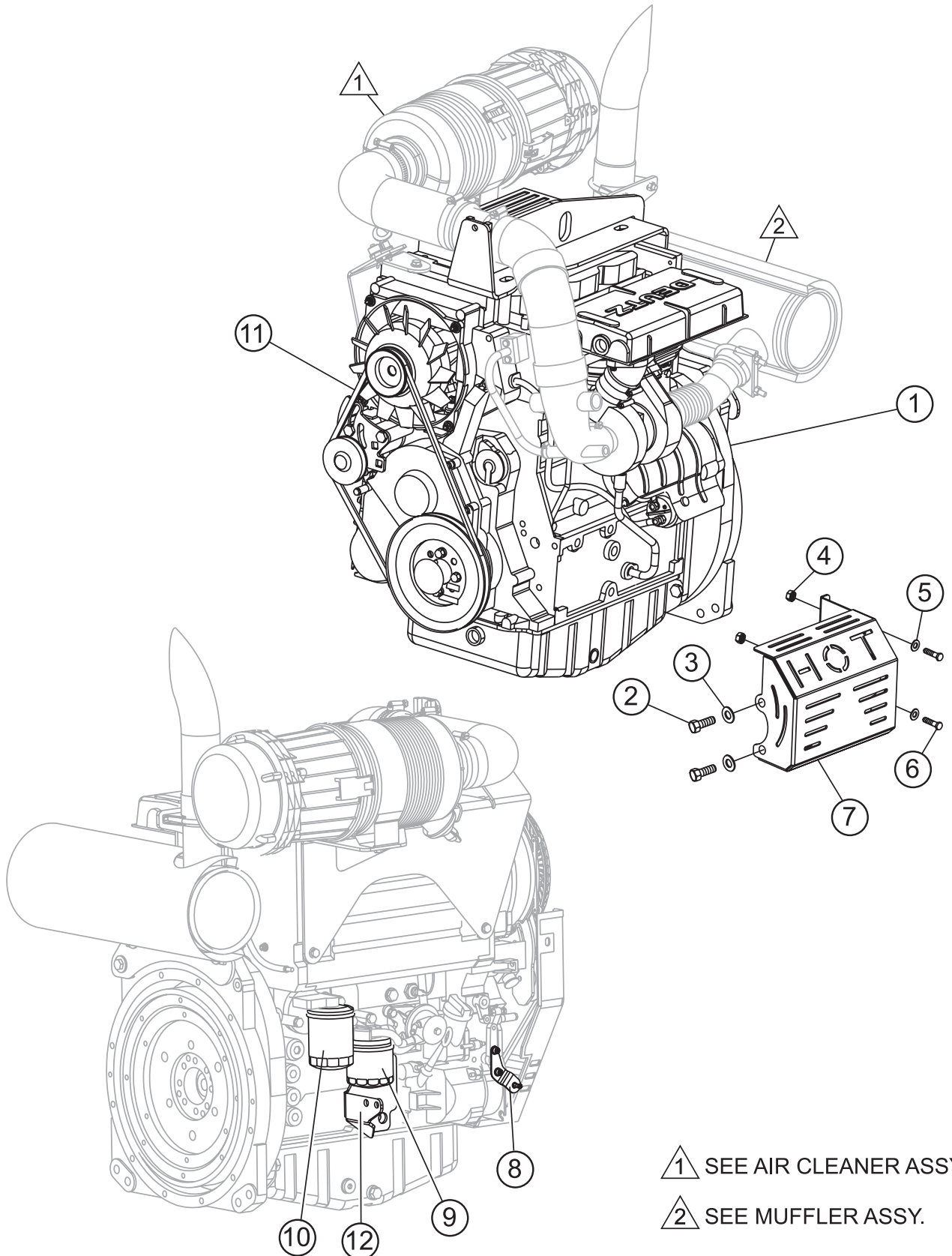

ENGINE ASSY.

<u>NO.</u>	<u>PART NO.</u>	<u>PART NAME</u>	<u>QTY.</u>	<u>REMARKS</u>
1	35396	ENGINE, DEUTZ 60HP BF3L2011 TRBO DSL	1	
2	2299	SCREW, HHC M8 - 1.25 X 16MM	2	
3	933241	WASHER, FLAT SAE 5/16 GRD 9 YZ	2	
4	10024	NUT, NYLOC 1/4 X 20	2	
5	933240	WASHER, FLAT SAE 1/4 GR 9 YZ	2	
6	915004	SCREW, HHC 1/4 - 20 X 7/8	2	
7	37473	HEAT SHIELD	1	SAFETY ITEM
8	37255	THROTTLE LEVER	1	
9	1174696	FILTER, FUEL DEUTZ	1	REPLACES 304010
10	1174416	FILTER, OIL DEUTZ	1	REPLACES 306012
11	21004-003	V-BELT, AX-35	1	
12	37256	BRACKET, THROTTLE/FNR CABLE	1	

THROTTLE CONTROL ASSY.

THROTTLE CONTROL ASSY.

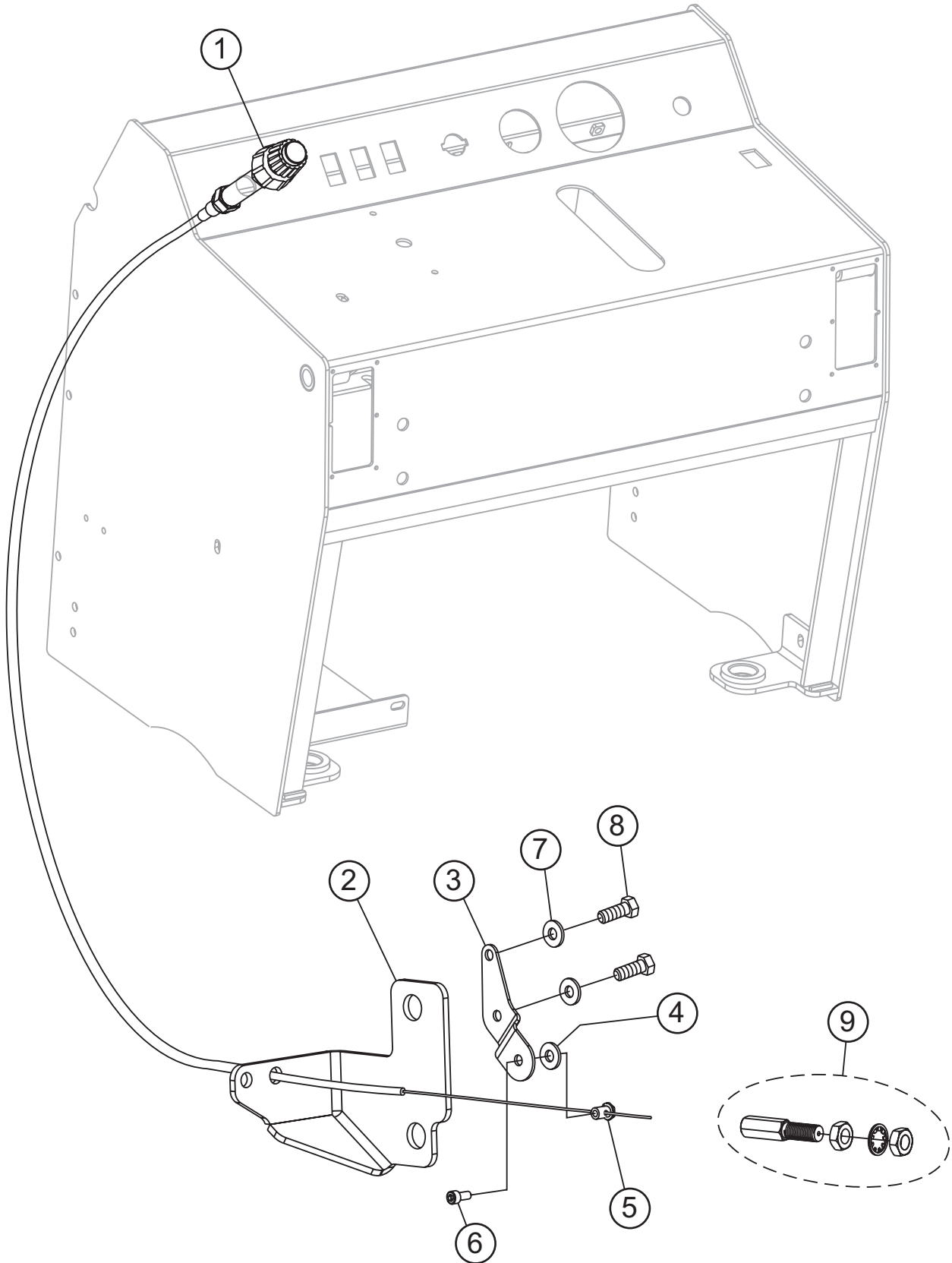

THROTTLE CONTROL ASSY.

THROTTLE CONTROL ASSY.

<u>NO.</u>	<u>PART NO.</u>	<u>PART NAME</u>	<u>QTY.</u>	<u>REMARKS</u>
1	37212	THROTTLE	1	
2	37256	BRACKET, THROTTLE/FNR CABLE	1	
3	37255	LEVER, THROTTLE	1	
4	933240	WASHER, FLAT SAE 1/4 GRD 9 YZ	1	
5	25624	SWIVEL, CABLE END W/ WASHER	1	
6	923113	SCREW, SHC 8 - 32 X 3/8 GRD 8	1	
7	23942-097	WASHER, M6	2	
8	12464	SCREW, HHC M6 - 1.0 X 16MM	2	
9	25634	BULK HEAD ADAPTOR	1	

ENGINE MOUNTS ASSY.

ENGINE MOUNTS ASSY.

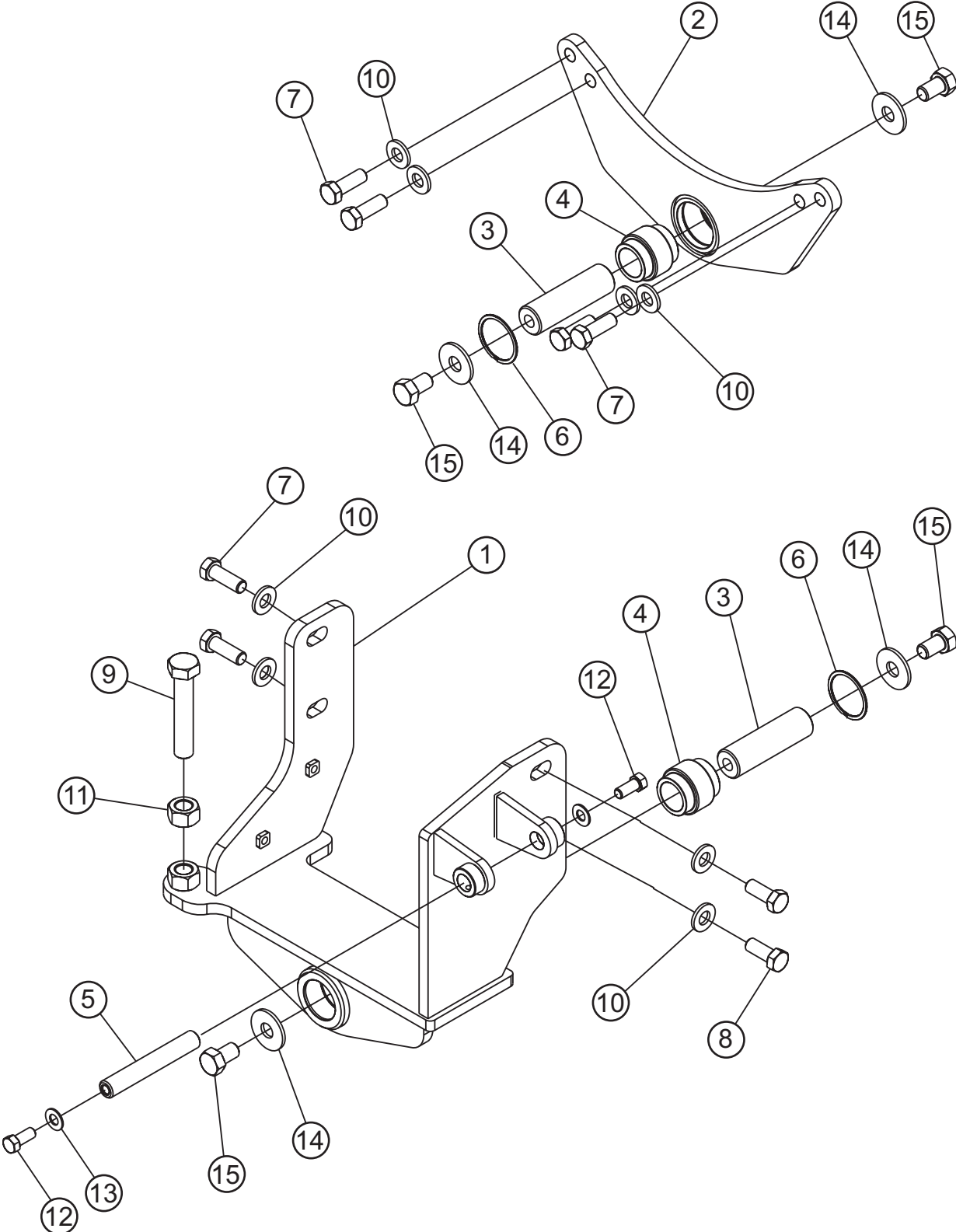

ENGINE MOUNTS ASSY.

ENGINE MOUNTS ASSY.

<u>NO.</u>	<u>PART NO.</u>	<u>PART NAME</u>	<u>QTY.</u>	<u>REMARKS</u>
1	37491	MOUNT, RH ENGINE	1	
2	37100	MOUNT, LH ENGINE	1	
3	37099	PIN, ENGINE PIVOT	2	
4	37031	BUSHING, SPHERICAL-ULTRASERT UC200	2	
5	37147	PIN, UPPER ENGINE PIVOT	1	
6	37313	RING, SPIRAL RETAINING WHM-200	2	
7	37310	SCREW, HHC M14-2.0 X 40MM GRD 10.9 NP	6	
8	37146	SCREW, HHC M14-2.0 X 35MM GRD 10.9 NP	2	
9	913838	SCREW, HHC 3/4 - 10 X 4 GRD5 ZINC	1	
10	933245	WASHER, FLAT SAE 9/16 GRD 9 YZ	8	
11	4389	NUT, HEX 3/4 - 10	1	
12	16530	SCREW, HHC 7/16 - 14 X 1	2	
13	933243	WASHER, FLAT SAE 7/16 GRD 9 YZ	2	
14	37037	WASHER, ENGINE PIVOT PIN	4	
15	21376	SCREW, HHC 5/8 - 11 X 1-1/2	4	

AIR CLEANER ASSY.

AIR CLEANER ASSY.

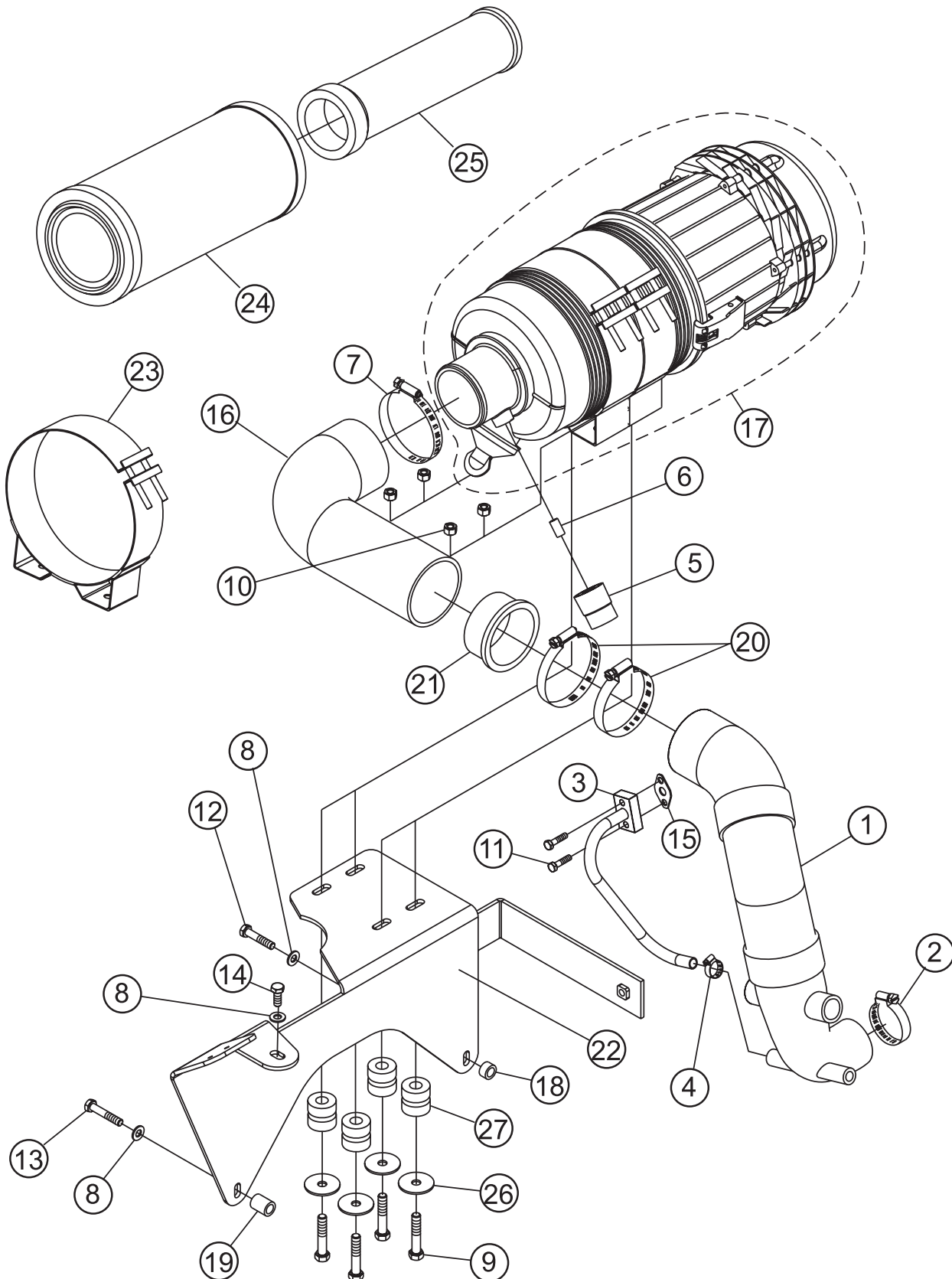

AIR CLEANER ASSY.

AIR CLEANER ASSY.

<u>NO.</u>	<u>PART NO.</u>	<u>PART NAME</u>	<u>QTY.</u>	<u>REMARKS</u>
1	37151	HOSE ASSY, AIR INTAKE	1	
2	10434	CLAMP, HOSE WORM # 32 1-9/16 TO 2"	1	
3	35309	TUBE, AIR INTAKE BREATHER	1	
4	15538	CLAMP, HOSE WORM # 6	1	
5	406018	INDICATOR, ELECTRICAL SERVICE	1	
6	65516	FITTING, NIPPLE 1/8" MP	1	
7	29218	CLAMP, HOSE WORM # 48	2	
8	933241	WASHER, FLAT SAE 5/16 GRD 9 YZ	3	
9	1665	SCREW, HHC 3/8 - 16 X 2	4	
10	10133	NUT, NYLOC 3/8 - 16	4	
11	M940653	SCREW, HHC M6 - 1.0 X 25MM GRD 10.9	2	
12	1928	SCREW, HHC M8 - 1.25 X 40MM	1	
13	9182	SCREW, HHC M8 - 1.25 X 45MM	1	
14	2866	SCREW, HHC M8 - 1.25 X 20MM	1	
15	35399	GASKET, AIR INTAKE TUBE	1	
16	37153	HOSE, 3.00 ID MOLDED 90 DEGREE	1	
17	37199	AIR CLEANER ASSEMBLY 3 INCH #7VLR	1	
18	37307	SPACER, AIR CLEANER MOUNT .375L	1	
19	37309	SPACER, AIR CLEANER MOUNT .875L	1	
20	962019	CLAMP, HOSE WORM # 44	2	
21	37317	BUSHING, AIR INTAKE 2.75 X 3.00	1	
22	37112	MOUNT, AIR FILTER	1	
23	37761	BRACKET, AIR INTAKE BODY	2	
24	P772579	PRIMARY FILTER, DEUTZ BF3L2013	1	
25	P775300	SAFETY FILTER, DEUTZ BF3L2014	1	
26	12832	WASHER, SNUBBING	4	
27	575001	RUBBER ISOLATOR, TPC #60166-1	4	

MUFFLER ASSY.

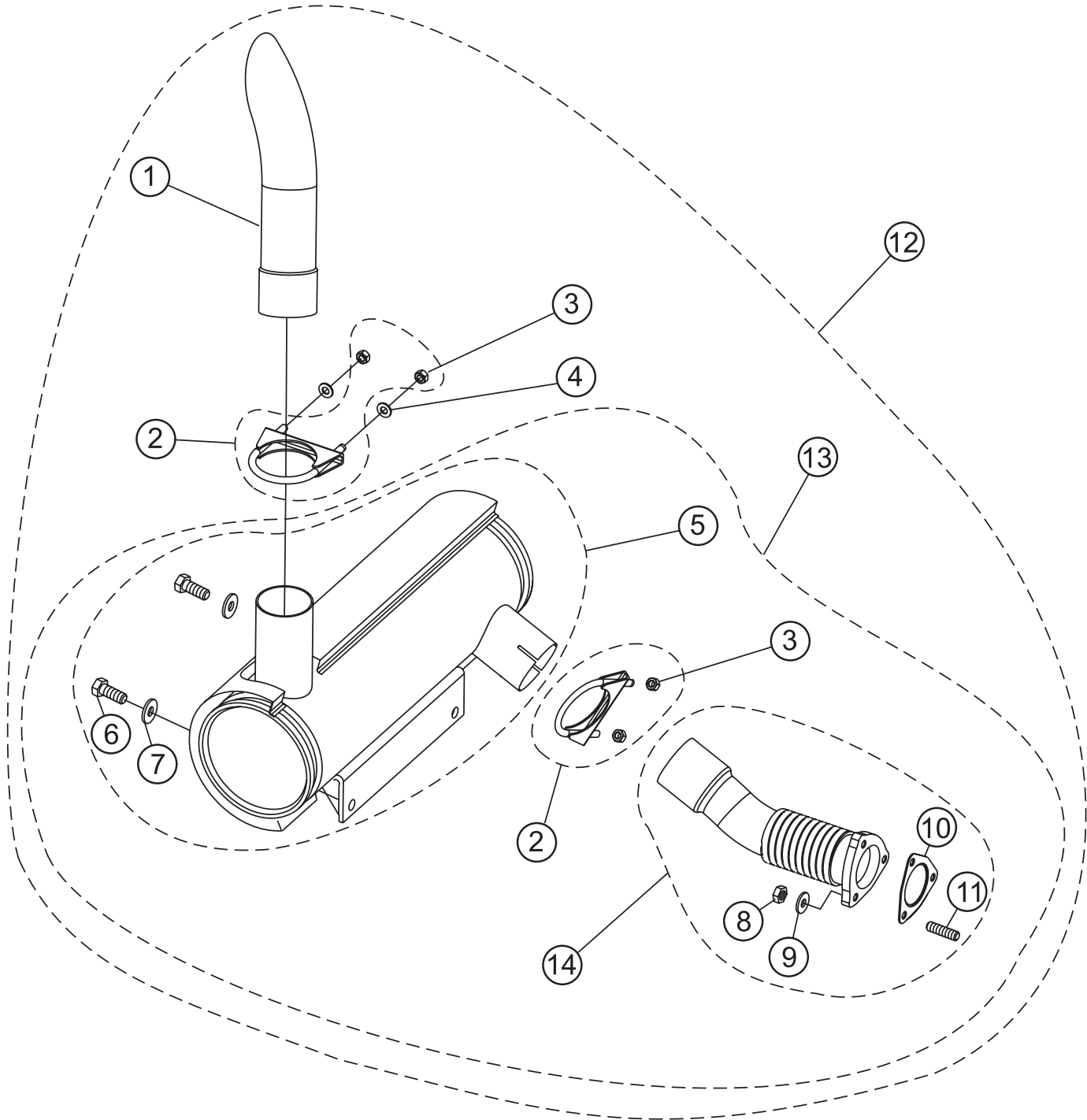

MUFFLER ASSY.

MUFFLER ASSY.

<u>NO.</u>	<u>PART NO.</u>	<u>PART NAME</u>	<u>QTY.</u>	<u>REMARKS</u>
1*	285003	EXHAUST, 12" EXTENSION	1	
2*#	570005	CLAMP, MUFFLER 2-1/2" 5/16 U-BOLT	2	
3*#	8131	NUT, FINISH L.H. 5/16 - 24	4	
4*#	933241	WASHER, FLAT SAE 5/16 GRD 9 YZ	4	
5*#	280005	MUFFLER	1	INCLUDES ITEMS W/%
6*#%	940693	SCREW, HHC M10 - 1.5 X 25MM GRD 10.9 NP	2	
7*#%	940358	WASHER, M10 X 21MM ZINC	2	
8*#\$	25592	NUT, M8 - 1.25"	3	
9*#\$	25591	WASHER, M8	3	
10*#\$	25642	GASKET, TURBO INLET DEUTZ	1	
11*#\$	25593	STUD, M8 - 1.25 X 30MM	3	
12	37143	MUFFLER ASSEMBLY COMPLETE	1	INCLUDES ITEMS W/*
13*	280002	MUFFLER AND FLEX KIT ASSEMBLY	1	INCLUDES ITEMS W/#
14*#	280004	FLEX KIT ASSEMBLY	1	INCLUDES ITEMS W/\$

LIFT BAIL ASSY.

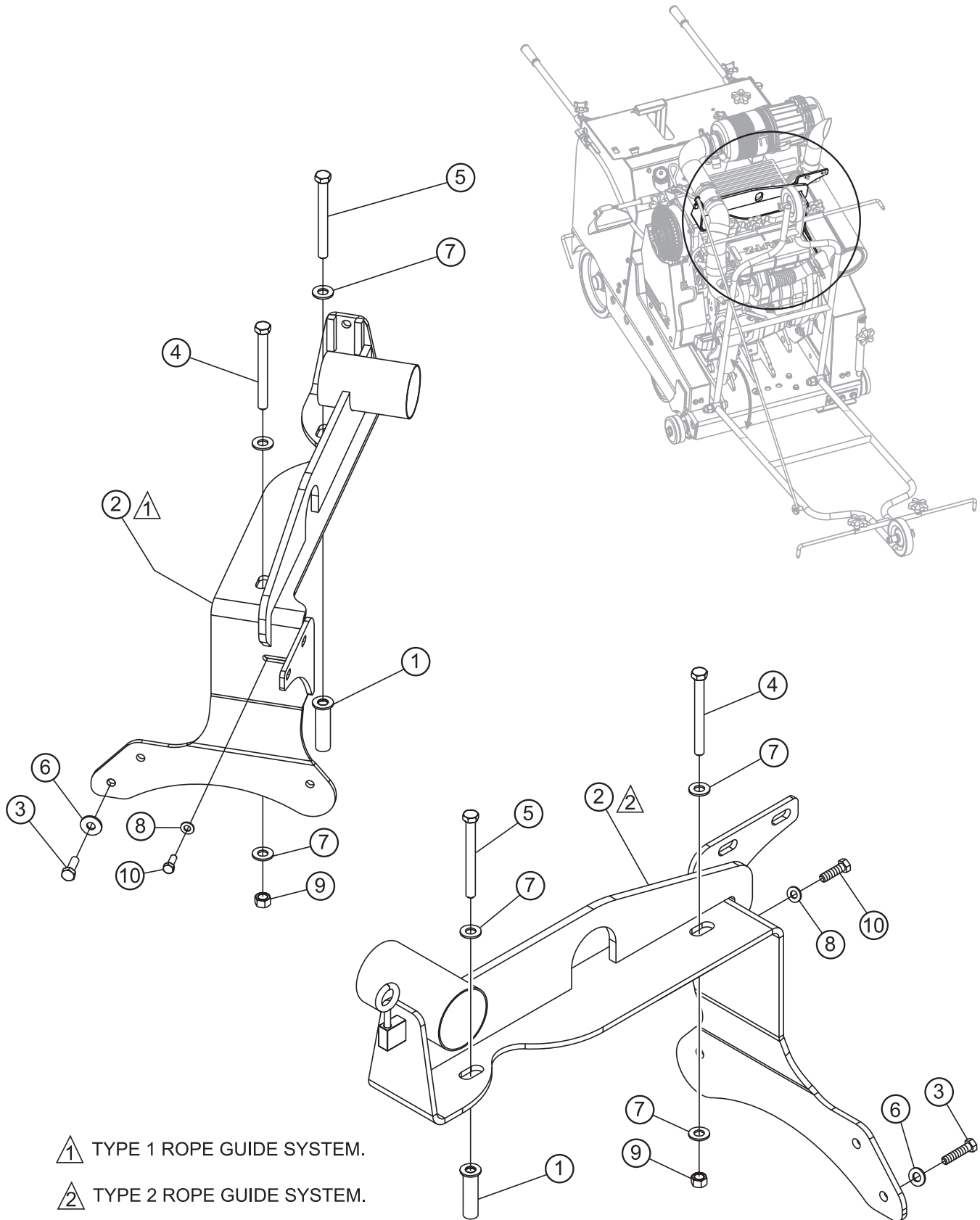

LIFT BAIL ASSY.

NO.	PART NO.	PART NAME	QTY.	REMARKS
1	37114	SPACER, DEUTZ ENGINE LIFTING BRACKET	1	
2	37115	BRACKET, DEUTZ ENGINE LIFTING	1	SEE NOTE BELOW
3	940694	SCREW, HHC M10 - 1.5 X 30MM FT 10.9 NP	1	
4	37314	SCREW, HHC M12 - 1.75 X 120MM TAP BOLT	1	
5	37315	SCREW, HHC M12 - 1.75 X 120MM 10.9 NP	1	
6	940358	WASHER, M10 X 21MM ZINC	1	
7	933244	WASHER, FLAT SAE 1/2 GRD 9 YZ	3	
8	933241	WASHER, FLAT SAE 5/16 GRD 9 YZ	1	
9	16083	NUT, HEX M12 - 1.75 NO PLATE	1	
10	06500-007	SCREW, HHC 5/16 - 18 X 7/8	1	



TYPE 2 ROPE GUIDE SYSTEM SUPERCEDES TYPE 1 ROPE GUIDE SYSTEM. SEE FRONT POINTER ASSY.

PLATFORM GUARDS/REAR POINTER ASSY.

PLATFORM GUARDS/REAR POINTER ASSY.

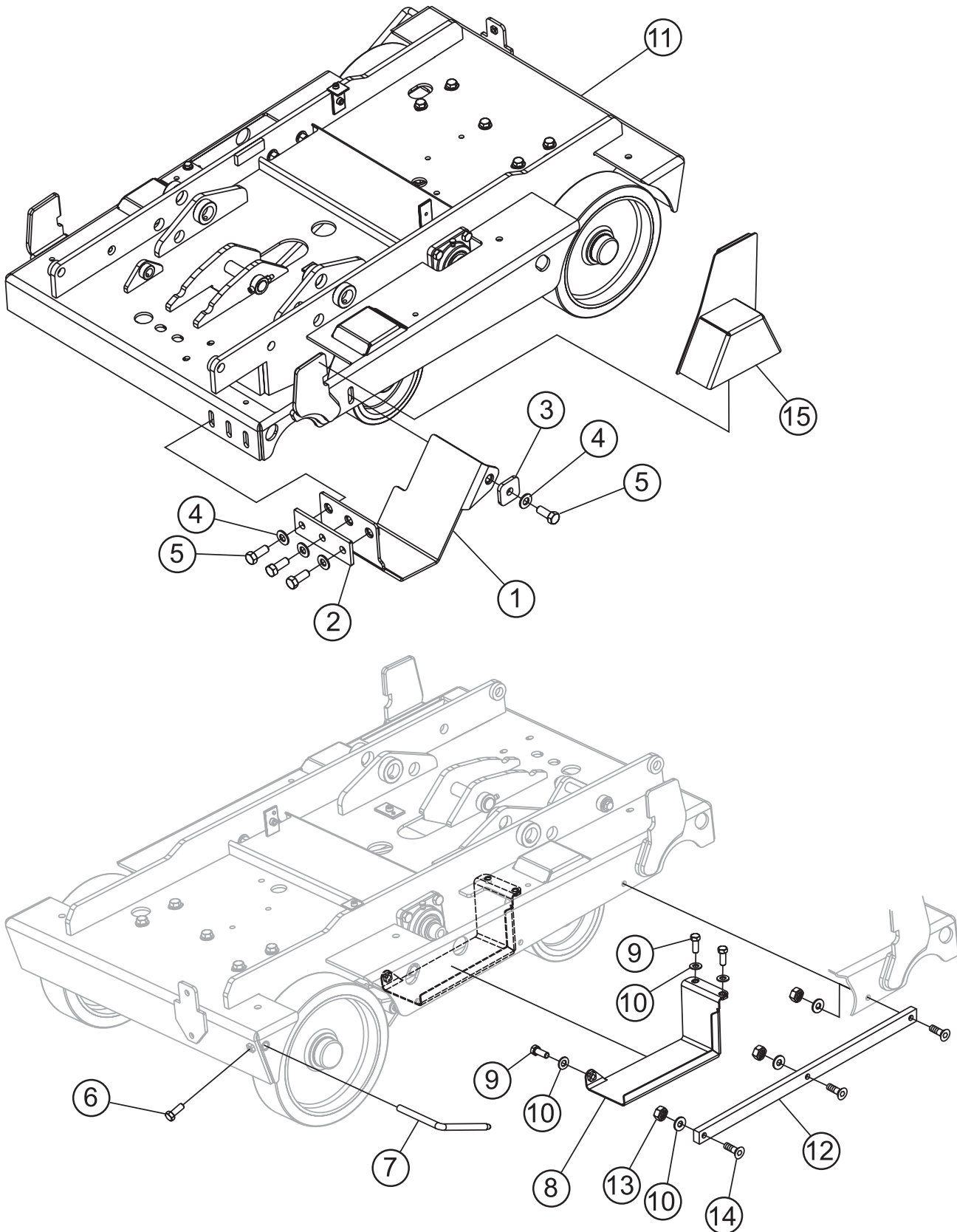

PLATFORM GUARDS/REAR POINTER ASSY.

PLATFORM GUARDS/REAR POINTER ASSY.

<u>NO.</u>	<u>PART NO.</u>	<u>PART NAME</u>	<u>QTY.</u>	<u>REMARKS</u>
1	37185	GUARD, BLADESHAFT PULLEY	1	SAFETY ITEM
2	583091	STRAP, LOWER BELT GUARD	1	
3	583092	WASHER, LOWER BELT PROTECTOR	1	
4	933244	WASHER, FLAT SAE 1/2 GRD 9 YZ	4	
5	3214	SCREW, HHC 1/2 - 13 X 1-1/4	4	
6	915105	SCREW, HHC 3/8 - 16 X 1.0 GRD 8	1	
7	110020	POINTER, REAR SAW	1	
8	37360	SHIELD, CONCRETE SLURRY	1	
9	915105	SCREW, HHC 3/8 - 16 X 1.0 GRD 8	3	
10	933242	WASHER, FLAT SAE 3/8 GRD 9 YZ	6	
11	37122	PLATFORM, W/A	1	
12	37450	STRIP, SLURRY CONTROL	1	
13	10133	NUT, NYLOC 3/8 - 16	3	
14	20982	SCREW, FHSC 3/8 - 16 X 1-1/2 PLATED	3	
15	M200000	GUARD, SAW BLADE COLLAR	1	

WHEEL DRIVE ASSY.

WHEEL DRIVE ASSY.

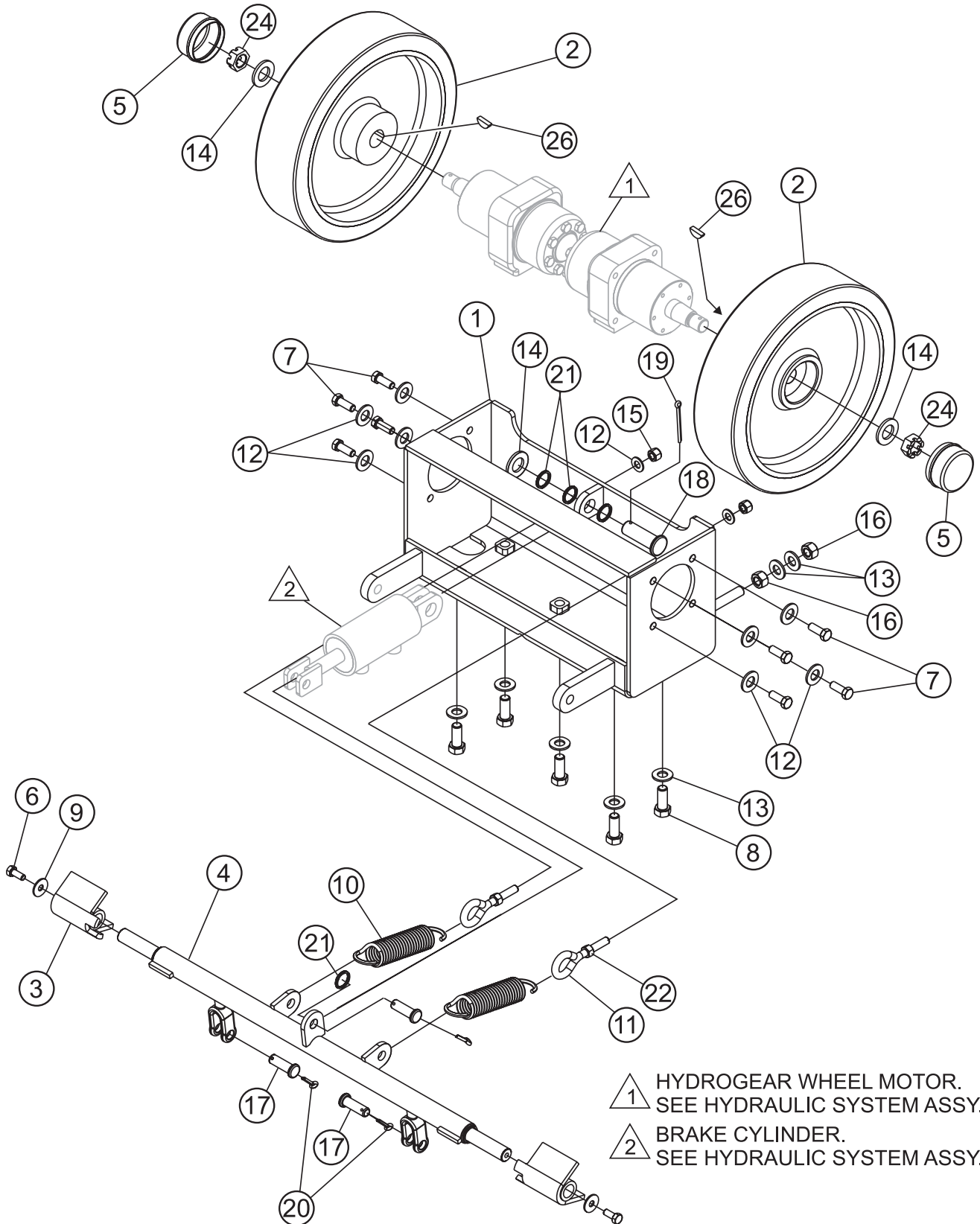

WHEEL DRIVE ASSY.

WHEEL DRIVE ASSY.

<u>NO.</u>	<u>PART NO.</u>	<u>PART NAME</u>	<u>QTY.</u>	<u>REMARKS</u>
1	37102	MOUNT, WHEEL MOTOR	1	
2	37095	WHEEL, 12 X 3 TAPERED BORE	2	
3	37096	BRAKE PAD	2	
4	37097	BRAKE ARM	1	
5	37138	CAP, WHEEL DUST	2	
6	0655	SCREW, HHC 5/16 - 18 X 3/4	2	
7	0205	SCREW, HHC 3/8 - 16 X 1.0	8	
8	3214	SCREW, HHC 1/2 - 13 X 1-1/4	5	
9	933213	WASHER, FENDER 5/16 X 1 ZINC	2	
10	37048	SPRING, 1.125 X .187 X 4 W/EYELET	2	
11	23858-001	EYEBOLT, 3/8 - 16 X 2.0	2	
12	933242	WASHER, FLAT SAE 3/8 GRD 9 YZ	10	
13	933244	WASHER, FLAT SAE 1/2 GRD 9 YZ	7	
14	933247	WASHER, FLAT SAE 3/4 GRD 9 YZ	3	
15	10133	NUT, NYLOC 3/8 - 16	2	
16	968011	NUT, HEX FINISH 1/2 - 13	2	
17	19974	PIN, CLEVIS 1/2 X 1.25	3	
18	966166	PIN, CLEVIS 3/4 X 2	1	
19	965105	PIN, COTTER 5/32 X 1-1/2	1	
20	965103	PIN, COTTER 5/32 X 1	3	
21	37322	SPRING, CREST TO CREST	4	
22	1456	NUT, HEX FINISH 3/8 - 16	2	
24	12426	NUT, SLOTTED 3/4-16	2	
26	0126	KEY, WOODRUFF #606 3/16 X 3/4	2	

FRONT AXLE ASSY.

FRONT AXLE ASSY.

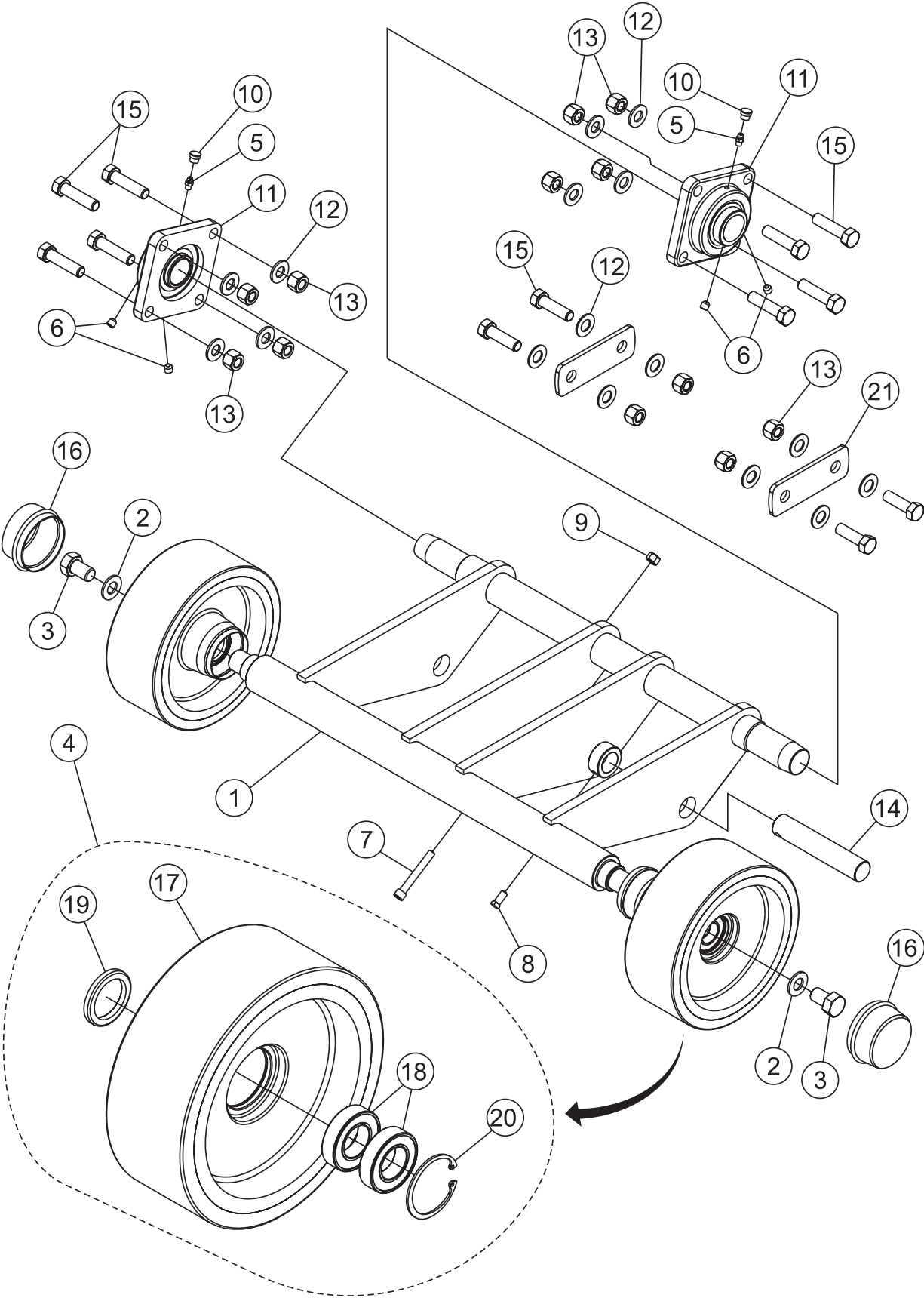

FRONT AXLE ASSY.

FRONT AXLE ASSY.

<u>NO.</u>	<u>PART NO.</u>	<u>PART NAME</u>	<u>QTY.</u>	<u>REMARKS</u>
1	37106	FRONT AXLE W/A	1	
2	933246	WASHER, FLAT 5/8 SAE GRD9 YZ	2	
3	06505-008	SCREW, HHC 5/8 - 11 X 1.00	2	
4	37132	WHEEL ASSEMBLY, FRONT	2	INCLUDES ITEMS W/*
5	2621	FITTING, GREASE ZERK STR 1/4 - 28	2	
6	26091	SCREW, SHS 1/4 - 28 X 1/4 CUP POINT	4	
7	2186	SCREW, SHC 5/16 - 18 X 2-1/4 PLTD	1	
8	926064	SCREW, SQHS CUP POINT 5/16 - 24 X 5/8	1	
9	5283	NUT, NYLOC 5/16 - 18	1	
10	1162 A	CAP, GREASE ZERK #2 YELLOW	2	
11	37040	BEARING, 1.250" FLANGE	2	
12	933244	WASHER, FLAT SAE 1/2 - 13 GD 8	16	
13	16629	NUT, NYLOC 12 - 13 GD 8	12	
14	37260	PIN, LIFT CYLINDER	1	
15	915211	SCREW, HHC 1/2 - 13 X 2 GRD8 YZ	12	
16	37138	CAP, WHEEL DUST	2	
17*	37131	WHEEL, 8 X 3 POLYURETHANE	2	
18*	460002	BEARING, BALL KOYO # 6005 SRS	4	
19*	485002	SEAL, OIL CR # 28655	2	
20*	576003	SNAP RING, - HO-185	2	
21	37165	PLATE, BACKING	2	

HYDRAULIC SYSTEM ASSY.

HYDRAULIC SYSTEM ASSY.

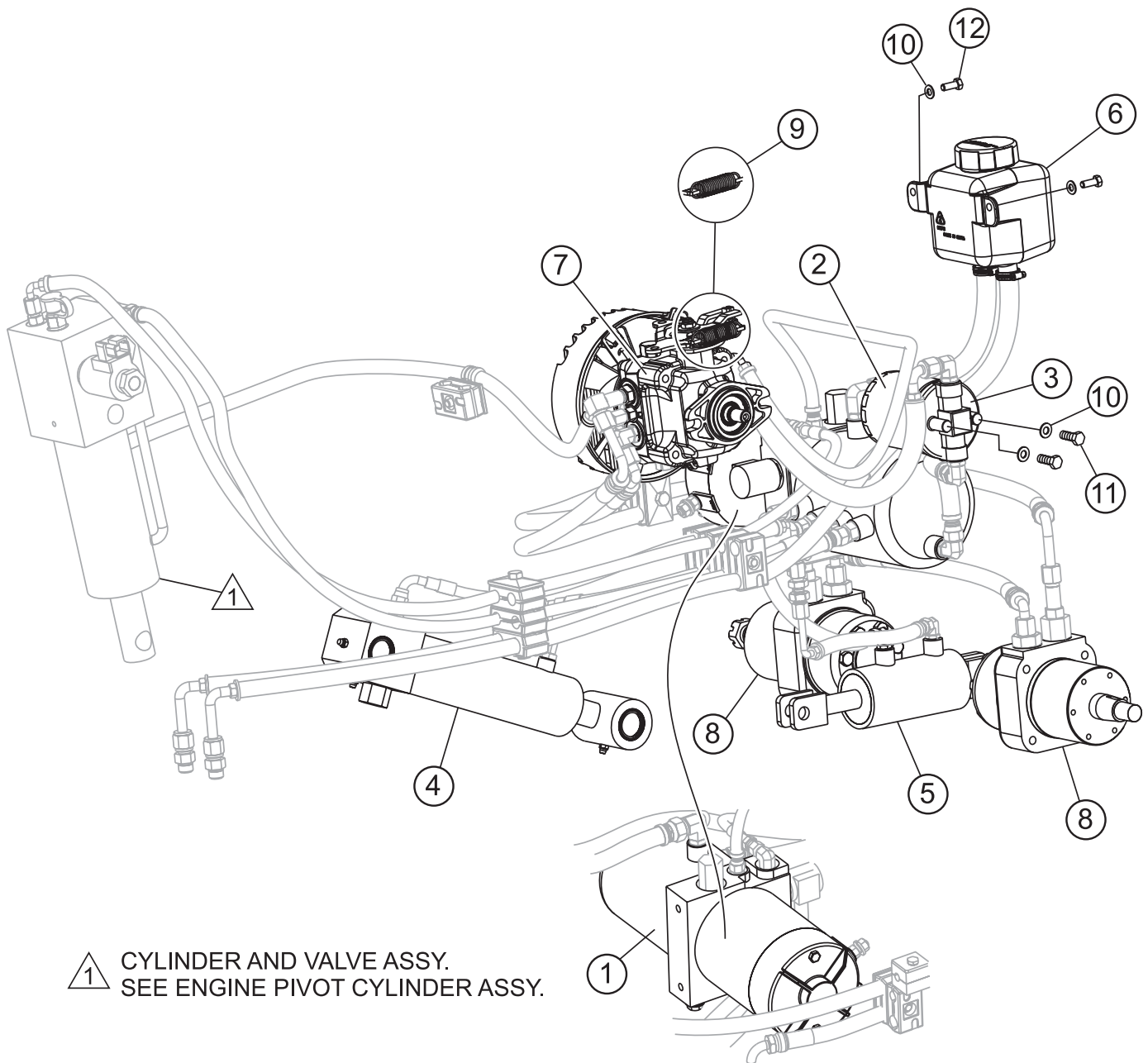

1 CYLINDER AND VALVE ASSY.
SEE ENGINE PIVOT CYLINDER ASSY.

HYDRAULIC SYSTEM ASSY.

HYDRAULIC SYSTEM ASSY.

<u>NO.</u>	<u>PART NO.</u>	<u>PART NAME</u>	<u>QTY.</u>	<u>REMARKS</u>
1	37113	PUMP, 24V DC LIFT - HYDROGEAR	1	
2	306006	FILTER, TRANSAXLE	1	
3	25617	FILTER HEAD, TRANSAXLE	1	
4	37121	LIFT CYLINDER ASSEMBLY	1	
5	37211	CYLINDER, BRAKE 2" X 1.5" STROKE	1	
6	37213	RESERVOIR, 350ML HYDROGEAR 71327	1	
7	37104	PUMP, HYDROGEAR	1	
8	37056	MOTOR, WHEEL - HYDROGEAR HGM-15P-7131	2	
9	37162	EXTENSION SPRING, 1.8" - 8.1 LB RATE	1	
10	933240	WASHER, FLAT SAE 1/4 GRD 9 YZ	4	
11	1579	SCREW, HHC 1/4 - 20 X .5	2	
12	4514	SCREW, HHC 1/4 - 20 X 5/8 GRD 5	2	

ENGINE PIVOT CYLINDER ASSY.

ENGINE PIVOT CYLINDER ASSY.

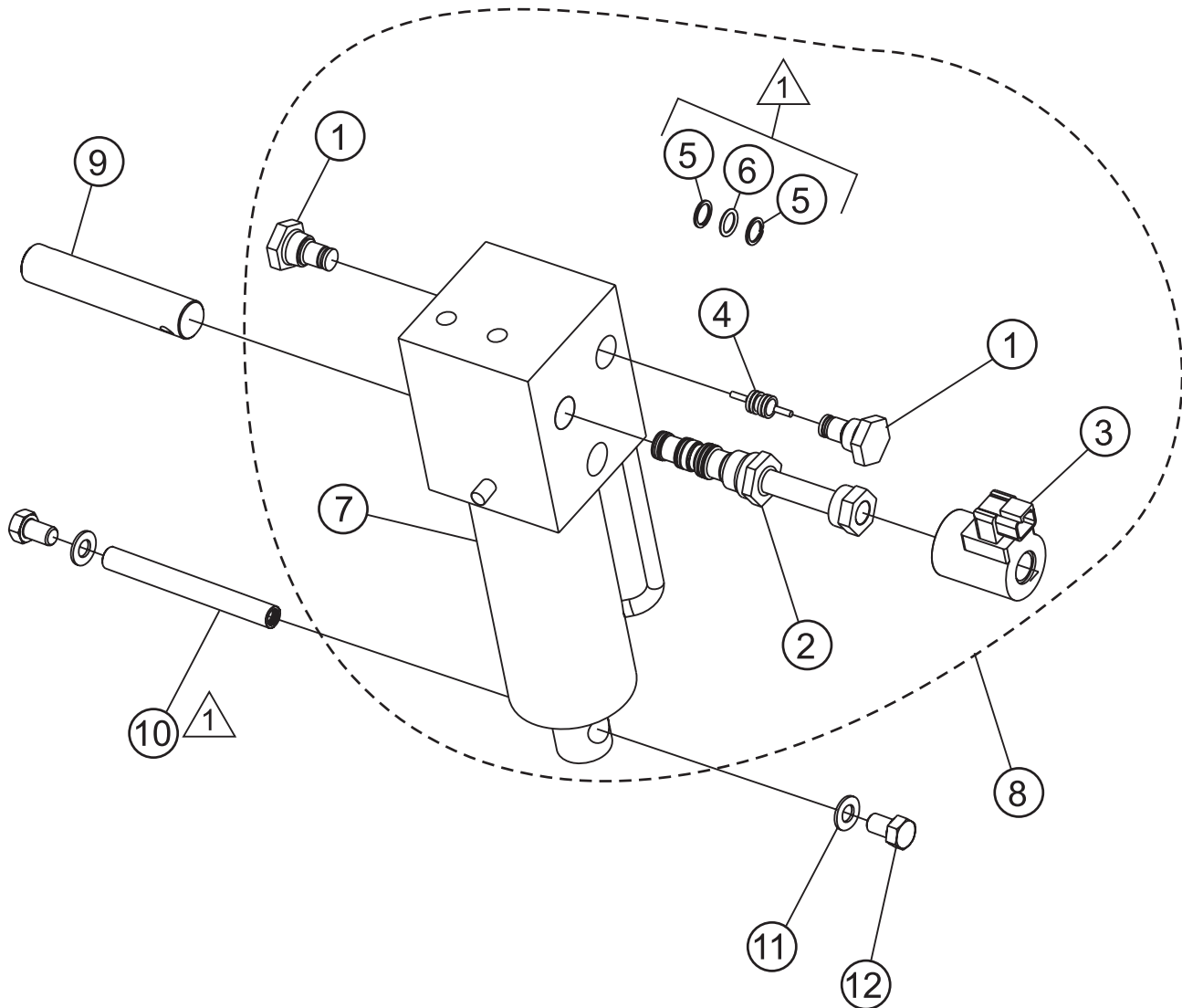

 ITEMS 5 AND 6 USED ON SAWS
S/N ZD3700241 AND BELOW

ENGINE PIVOT CYLINDER ASSY.

ENGINE PIVOT CYLINDER ASSY.

<u>NO.</u>	<u>PART NO.</u>	<u>PART NAME</u>	<u>QTY.</u>	<u>REMARKS</u>
1*	37445	VALVE, CHECK	2	
2*	37446	VALVE, CARTRIDGE 4-WAY 2-POSITION	1	
3*	37447	SOLENOID COIL 12VDC	1	
4*	37448	PISTON, PILOT	1	
5*	37449	PISTON, BACKUP RING	2	S/N ZD3700241 AND BELOW
6*	37492	O-RING	1	S/N ZD3700241 AND BELOW
7*	37390	CYLINDER, HYDRAULIC	1	
8	37495	CYLINDER AND VALVE ASSEMBLY	1	INCLUDES ITEMS W/*
9	37260	PIN, LIFT CYLINDER	1	
10	37166	PIN, LOWER ENGINE PIVOT	1	
11	933243	WASHER, FLAT SAE 7/16 GRD 9 YZ	2	
12	16530	SCREW, HHC 7/16 - 14 X 1	2	

HYDRAULIC HOSES ASSY.

HYDRAULIC HOSES ASSY.

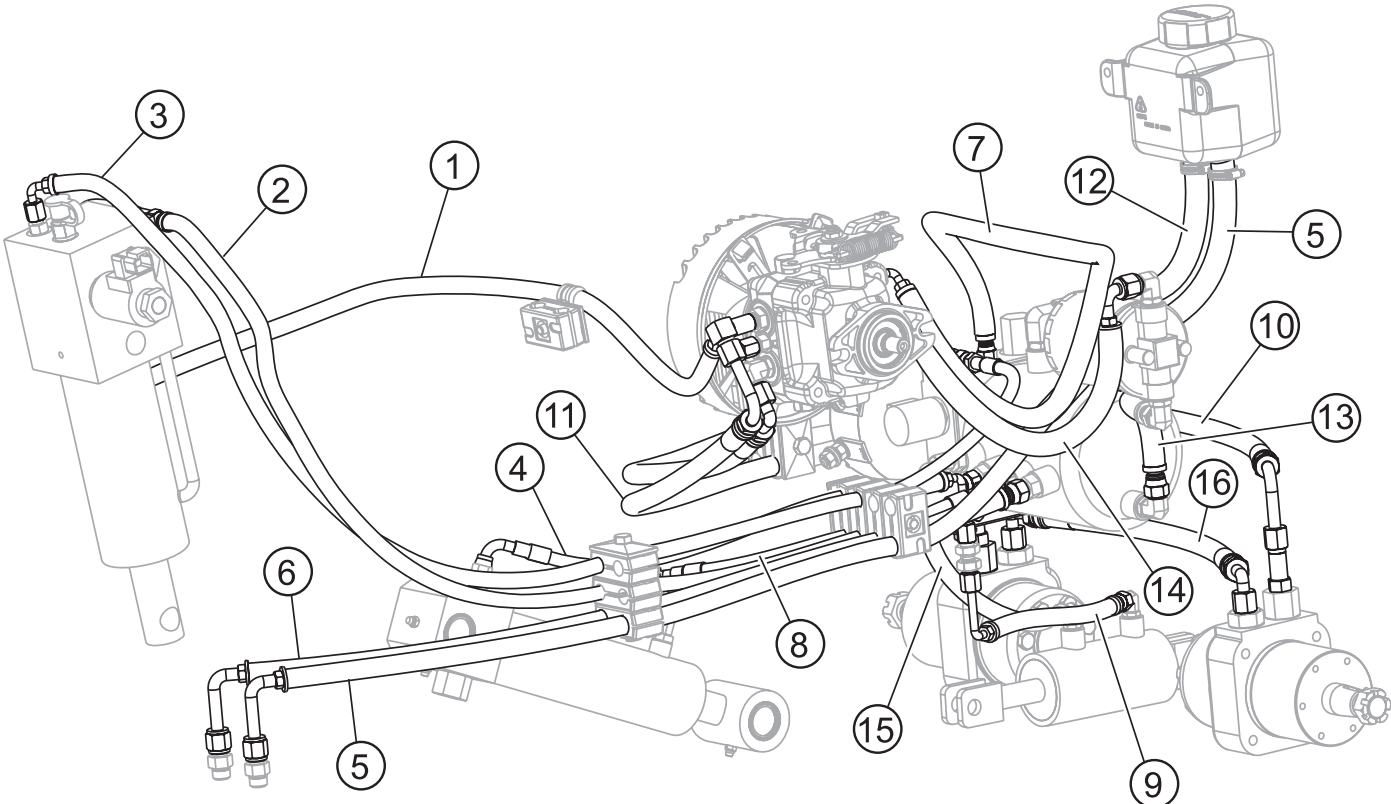

HYDRAULIC HOSES ASSY.

HYDRAULIC HOSES ASSY.

<u>NO.</u>	<u>PART NO.</u>	<u>PART NAME</u>	<u>QTY.</u>	<u>REMARKS</u>
1	37475	HOSE ASSEMBLY, #4 LP	1	
2	37476	HOSE ASSEMBLY, #4 LP	1	
3	37477	HOSE ASSEMBLY, #4 LP	1	
4	37290	HOSE ASSEMBLY, #4 HP PARFLEX	1	
5	37295	HOSE ASSEMBLY, #6-8 LP	1	
6	37294	HOSE ASSEMBLY, #6 LP	1	
7	37347	HOSE ASSEMBLY, #6 LP	1	SEE NOTE BELOW
8	37291	HOSE ASSEMBLY, #4 PARFLEX	1	
9	37292	HOSE ASSEMBLY, #4 LP	1	
10	37278	HOSE ASSEMBLY, #6 PARFLEX	1	
11	37279	HOSE ASSEMBLY, #6 PARFLEX	1	
12	37283	HOSE ASSEMBLY, #8 LP	1	
13	37281	HOSE ASSEMBLY, #6 LP	1	
14	37282	HOSE ASSEMBLY, #6 LP	1	
15	37293	HOSE ASSEMBLY, #4 LP	1	
16	37280	HOSE ASSEMBLY, DRIVE MOTOR CROSSOVER	1	

HYDRAULIC FITTINGS AND CLAMPS ASSY.

HYDRAULIC FITTING AND CLAMPS ASSY.

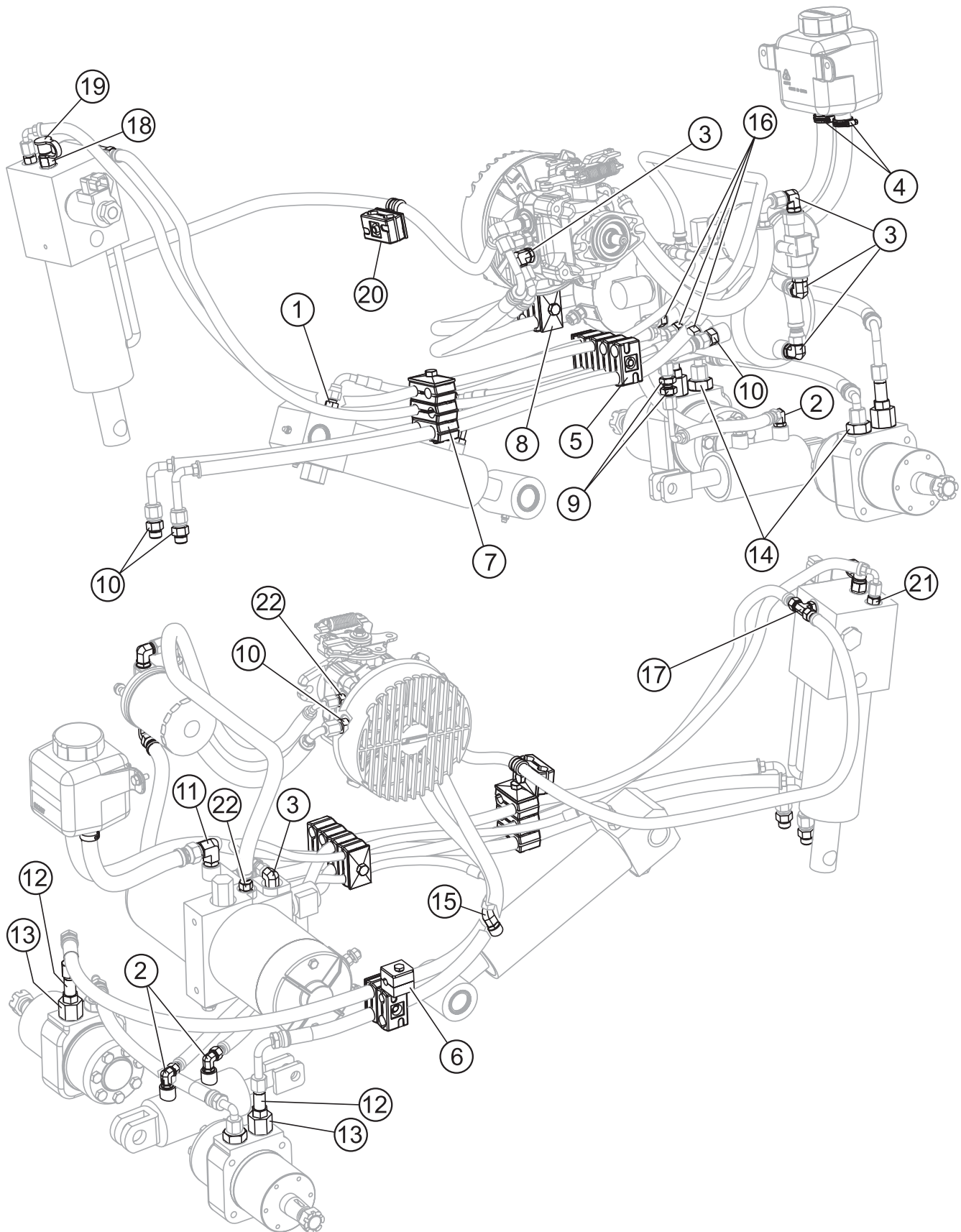

HYDRAULIC FITTINGS AND CLAMPS ASSY.

HYDRAULIC FITTING AND CLAMPS ASSY.

<u>NO.</u>	<u>PART NO.</u>	<u>PART NAME</u>	<u>QTY.</u>	<u>REMARKS</u>
1	21095	FITTING, STR 4MJ - 4MO	1	
2	368817	FITTING, 90 4MJ - 4MO	2	
3	11722	FITTING, 90 6MJ - 6MO	4	
4	15538	CLAMP, HOSE WORM #6, 7/16" TO 7/8"	2	
5	37793	CLAMP ASSEMBLY, HOSE	1	
6	37352	CLAMP ASSEMBLY, 5/16 HOSE	1	
7	37792	CLAMP ASSEMBLY, HOSE	1	
8	37433	CLAMP ASSEMBLY, HOSE	1	
9	366437	FITTING, BULKHEAD #4 JIC	1	
10	11721	FITTING, STR 6MJ - 6MO	4	
11	12431	FITTING, 90 8MJ - 6MO	1	
12	21115	FITTING, STR 6MJ - 6MO LONG	2	
13	37405	FITTING, 10MO X - 6FO - ST	2	
14	37406	FITTING, 6MJ X 10MO - ST	2	
15	21159	FITTING, 45 4MJ - 4MO	1	
16	367470	FITTING, STR 4MJ - 6MO	3	
17	37788	FITTING, TEE 4MO - 4MO - 4MJ	1	
18	12147	FITTING, QD 6MO DIAGN PARKER PD 361	1	
19	12148	CAP, DUST DIAG PARKER PD6 - 285	1	
20	35022	CLAMP, LOOP CUSHIONED #8	1	
21	37493	FITTING, ORIFICE 4MJ - 4MO X .100	1	
22	11887	FITTING, STR 6MJ - 4MO	2	SEE NOTE BELOW

FRONT POINTER ASSY.

FRONT POINTER ASSY.

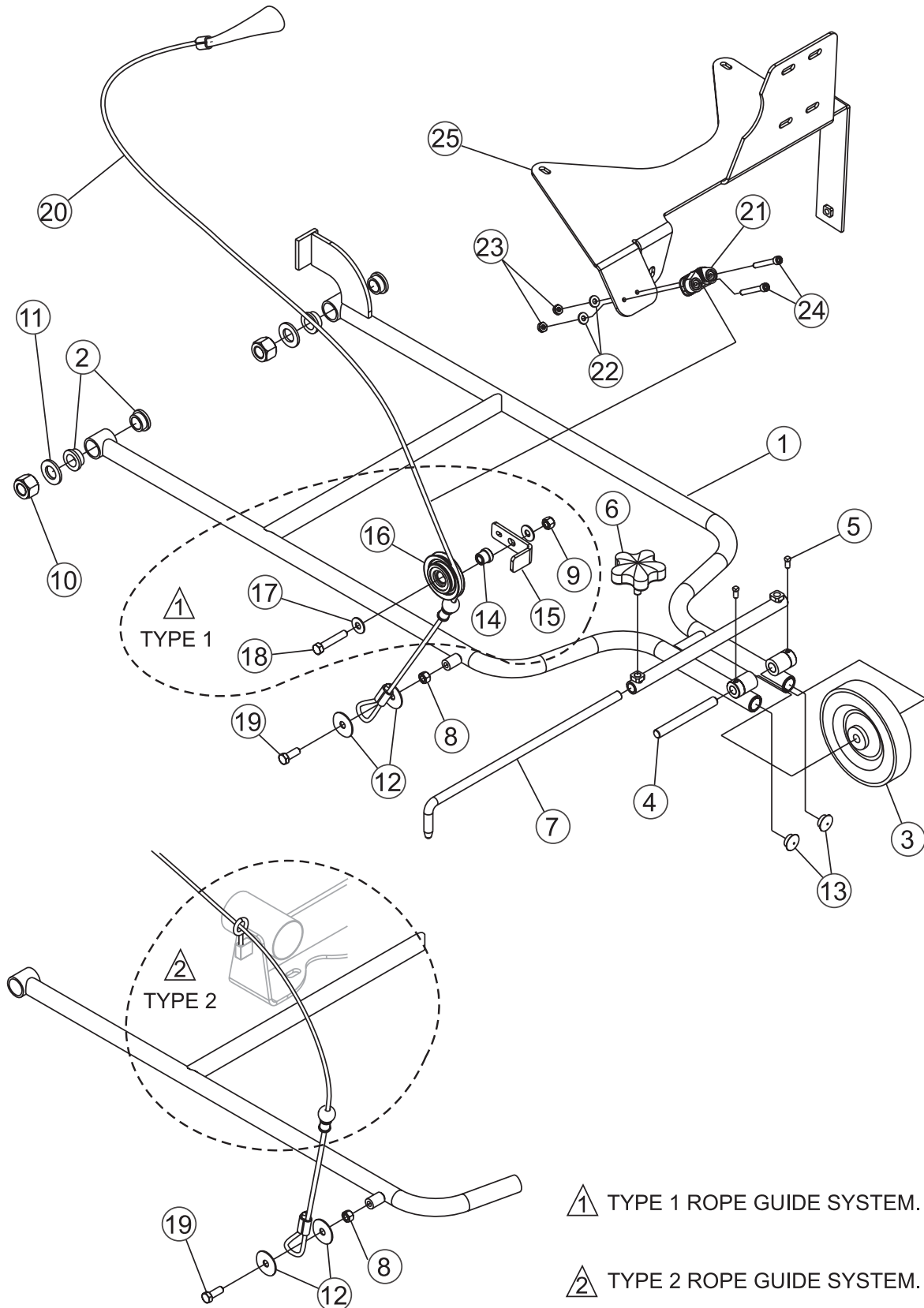

FRONT POINTER ASSY.

FRONT POINTER ASSY.

<u>NO.</u>	<u>PART NO.</u>	<u>PART NAME</u>	<u>QTY.</u>	<u>REMARKS</u>
1	37182	POINTER	1	
2	582008	BUSHING, FLANGE 1.0 OD X .75 ID	4	
3	500005	WHEEL, POINTER 6" X 1"	1	
4	37178	AXLE, POINTER WHEEL	1	
5	926006	SCREW, SQHS CP 1/4 - 20 X1/2	2	
6	15503	KNOB, COMFORT GRIP STAR	1	
7	110038	SAW POINTER 15" RH FRONT	1	
8	1456	NUT, HEX FINISH 3/8 - 16	1	
9	10133	NUT, NYLOC 3/8 - 16	1	SEE NOTE BELOW
10	5070 B	NUT, NYLOC 3/4 - 10	2	
11	933247	WASHER, FLAT SAE 3/4 GRD 9 YZ	2	
12	3233	WASHER, FENDER 1.50 OD X 3/8 ID	2	
13	37261	PLUG, FINISHING 3/4"	2	
14	544002	SHOULDER, ADAPTER	1	SEE NOTE BELOW
15	125043-3	RETAINER, SAW POINTER CABLE	1	SEE NOTE BELOW
16	540039	PULLEY, POINTER ROPE	1	SEE NOTE BELOW
17	10136	WASHER, FLAT SAE 3/8	2	SEE NOTE BELOW
18	1665	SCREW, HHC 3/8 - 16 X 2	1	SEE NOTE BELOW
19	0205	SCREW, HHC 3/8 - 16 X 1.0	1	
20	574003	ROPE, POINTER ASSY.	1	INCLUDES BALL & CRIMP
21	574002	CAM CLEAT	1	
22	15173	WASHER, FLAT #8	2	
23	13287	NUT, NYLOC 8 - 32	2	
24	923199	SCREW, SHC 8 - 32 X 1-1/4	2	
25	37112	MOUNT, AIR FILTER	1	

BELT DRIVE ASSY.

BELT DRIVE ASSY.

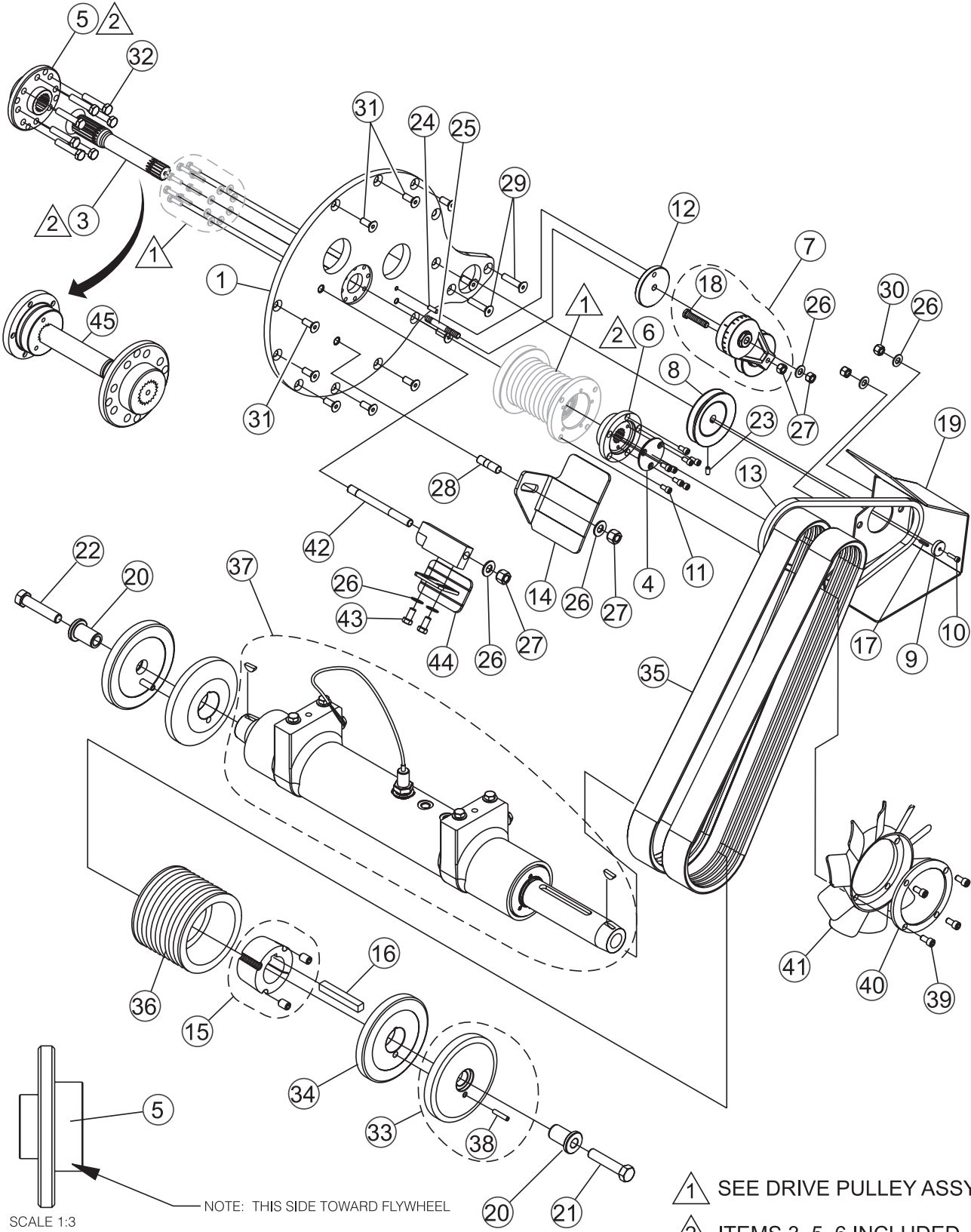

▲ 1 SEE DRIVE PULLEY ASSY.

▲ 2 ITEMS 3, 5, 6 INCLUDED WITH ITEM 45, SPLINED DRIVE ASSY, P/N 37833

SCALE 1:3

NOTE: THIS SIDE TOWARD FLYWHEEL

BELT DRIVE ASSY.

BELT DRIVE ASSY.

<u>NO.</u>	<u>PART NO.</u>	<u>PART NAME</u>	<u>QTY.</u>	<u>REMARKS</u>
1	37001	PLATE, ENGINE ADAPTER-DEUTZ	1	
3#		SHAFT, ENGINE DRIVE-DEUTZ	1	
4	37019	PLATE, PULLEY DRIVE COVER	1	
5#		FLANGE, ENGINE DRIVE-DEUTZ	1	
6#		FLANGE, PULLEY DRIVE-DEUTZ	1	
7	37137	BELT TENSIONER ASSY.	1	INCLUDES ITEMS W/*
8	37002	PULLEY, PUMP DRIVE 3.75" A-SECTION	1	
9	37319	WASHER, THRUST 1.00 OD X .265 L X .265 H	1	
10	37320	SCREW, SHC 10-32 X 3/4	1	
11	923201	SCREW, SHC 1/4 - 20 X 1/2	8	
12	37267	SPACER, BELT TENSIONER	1	
13	21004-003	BELT, AX-35	1	
14	37755	SHOE, LOWER BELTSIDE	1	
15	460016	BUSHING, TAPER-LOCK 2517 X 1-7/8	1	FITS 20", 26", 30", 36"
15	460023	BUSHING, TAPER-LOCK 2012 X 1-7/8	1	FITS 16"
16	10057-061	KEY, 1/2" SQ X 3-1/2"	1	
17	37269	KEY, SQUARE 1/8 X 3/4	1	
18*	37266	SCREW, MODIFIED HEAD 3/8 X 1-3/4	1	
19	37218	GUARD, PUMP DRIVE	1	SAFETY ITEM
20	582012	BUSHING, QUICK DISCONNECT BLADE SHAFT	2	
21	915315	SCREW, HHC 5/8 - 11 X 3 GR8	1	
22	915316	SCREW, HHC 5/8 - 11 X 3 LH GR8	1	
23	10138	SCREW, SHS 1/4 - 20 X 1/2 NP	1	
24	926919	PIN, DOWEL 1/4 X 3/4	1	
25	37268	STUD, 3/8 - 16 X 3 SELF-LOCKING	1	
26	933242	WASHER, FLAT SAE 3/8 GRD 9 YZ	5	
27	1456	NUT, HEX FINISH 3/8 - 16	4	
28	37762	STUD, 1/2 - 13 X 1-3/4	1	
29	924289	SCREW, FHSC 3/8 - 16 X 1-3/4	2	
30	10133	NUT, NYLOC 3/8 - 16	2	
31	939978	SCREW, FHSC M10 - 1.5 X 25MM NP	11	
32	938422	SCREW, HHC M10 - 1.0 X 50MM 10.9 NP	8	
33	37177	FLANGE ASSY, 6.0" OUTER BLADE	2	FITS 30", 36" BELT DRIVE
33	37169	FLANGE ASSY, 5.0" OUTER BLADE	2	FITS 16", 20", 26" BELT DRIVE
34	37176	FLANGE ASSY, 6.0" INNER BLADE	2	FITS 30", 36" BELT DRIVE
34	37168	FLANGE ASSY, 5.0" INNER BLADE	2	FITS 16", 20", 26" BELT DRIVE
35	520007	V-BELT, 5G 3 VX 530 POWERBAND	2	
36	540047	PULLEY, 5.6 10G 3V X 2517 TAPER	1	FITS 36" BELT DRIVE
36	540041	PULLEY, 5.3 10G 3V X 2517 TAPER	1	FITS 30" BELT DRIVE
36	540040	PULLEY, 5.0 10G 3V X 2517 TAPER	1	FITS 26" BELT DRIVE
36	540035	PULLEY, 4.75 10G 3V X 2517 TAPER	1	FITS 20" BELT DRIVE
36	540046	PULLEY, 4.2 10G 3V X 2012 TAPER	1	FITS 16" BELT DRIVE

CONTINUED NEXT PAGE

BELT DRIVE ASSY.

BELT DRIVE ASSY. (CONTINUED)

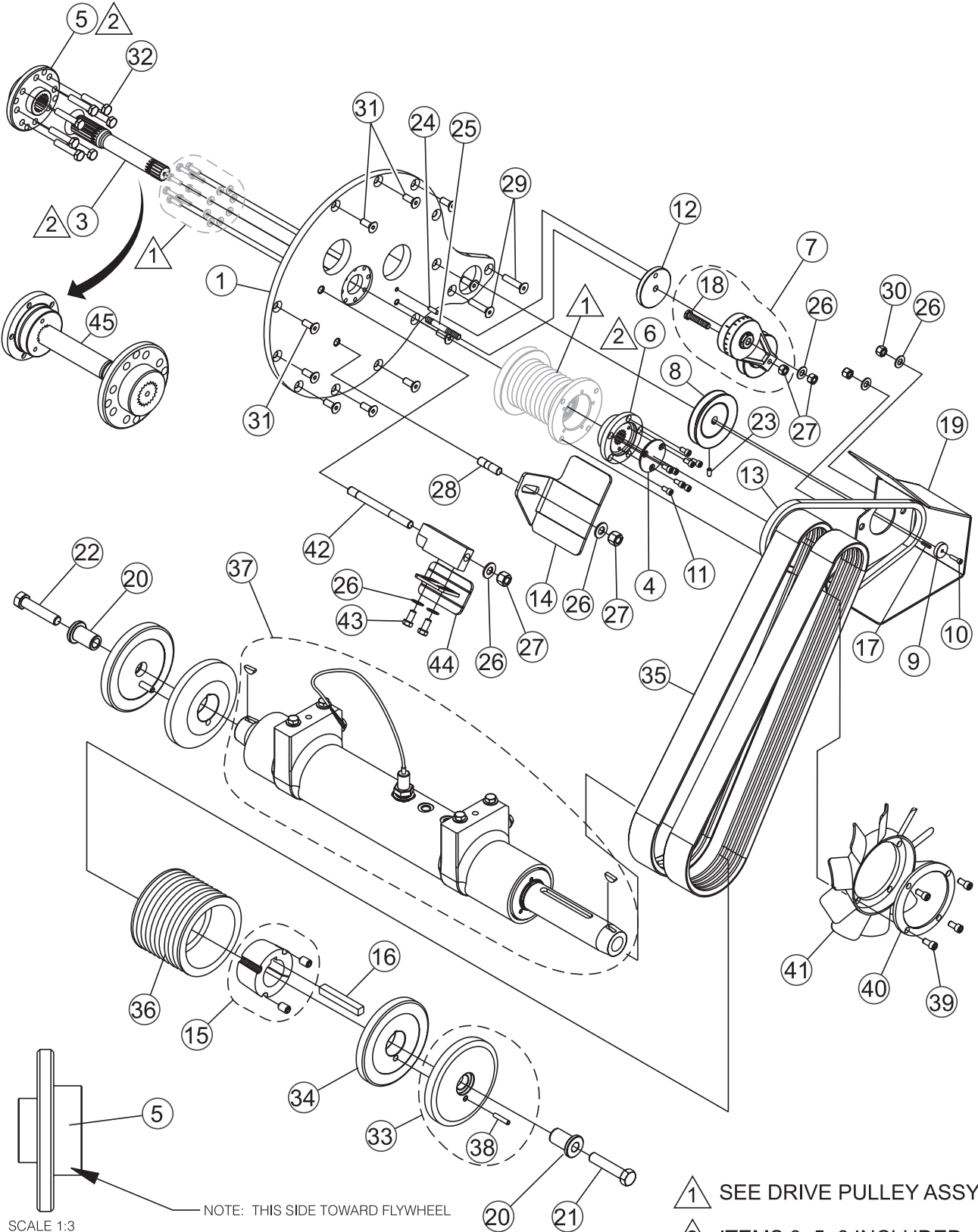

SCALE 1:3

NOTE: THIS SIDE TOWARD FLYWHEEL

- ▲ 1 SEE DRIVE PULLEY ASSY.
- ▲ 2 ITEMS 3, 5, 6 INCLUDED WITH ITEM 45, SPLINED DRIVE ASSY, P/N 37833

BELT DRIVE ASSY.

BELT DRIVE ASSY. (CONTINUED)

<u>NO.</u>	<u>PART NO.</u>	<u>PART NAME</u>	<u>QTY.</u>	<u>REMARKS</u>
37	37134	BLADE SHAFT ASSY.	1	
38	926790	PIN, DOWEL 3/8 X 1-3/4	2	INCLUDED W/ ITEM 33
39	25992	SCREW, SHC 12 - 24 X 1/2	4	
40	37735	RING, FAN MOUNT	1	
41	37734	FAN, CW 8" 10 BLADE	1	
42	37763	STUD, 1/2 - 13 X 5-1/2	1	
43	915103	SCREW, HHC 3/8 - 16 X 3/4 GR8 YZ	2	
44	37756	SHOE, UPPER BELTSIDE	1	
45	37833	SPLINED DRIVE ASSY.	1	INCLUDES ITEMS W/#

DRIVE PULLEY ASSY.

DRIVE PULLEY ASSY.

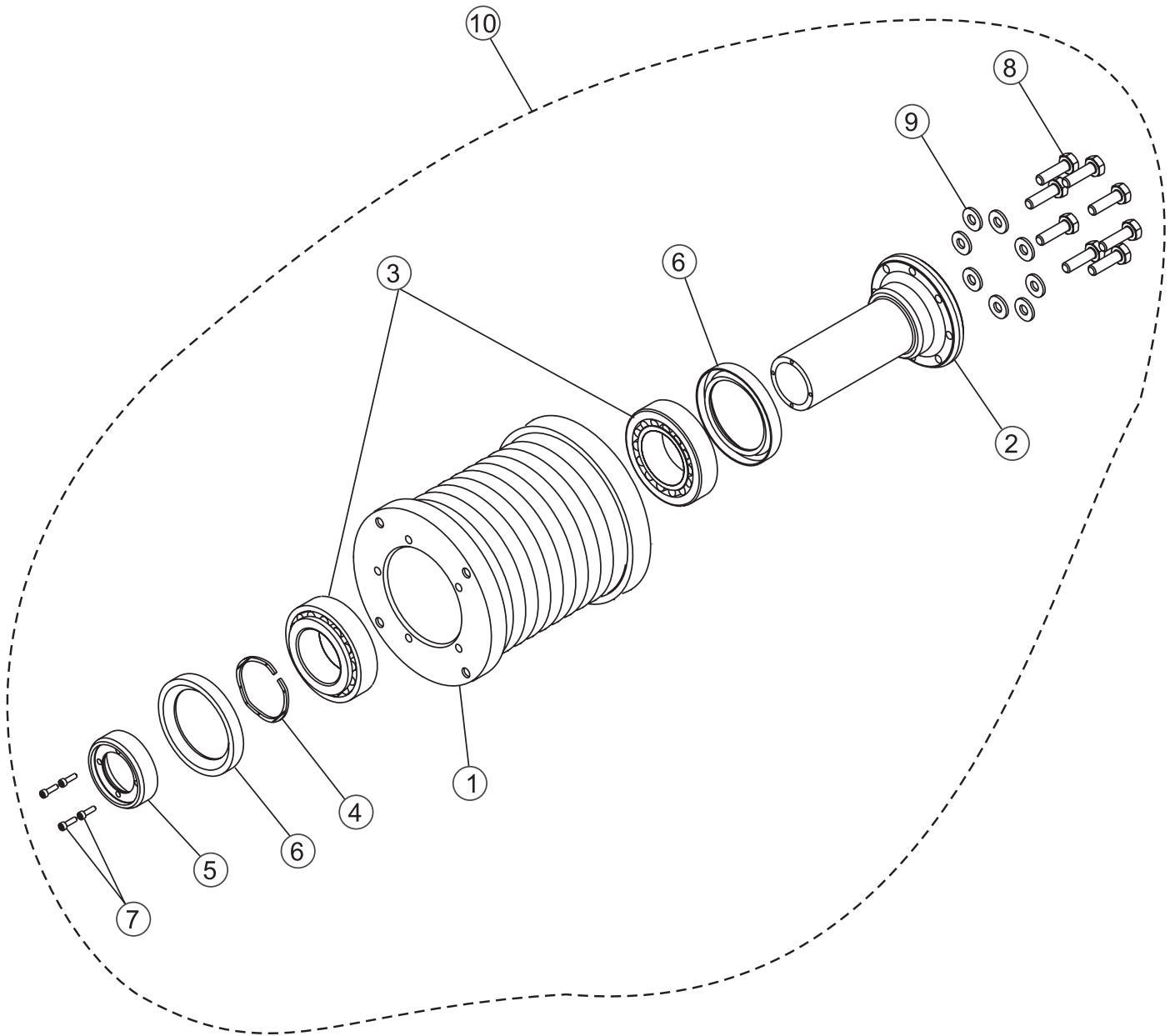

DRIVE PULLEY ASSY.

DRIVE PULLEY ASSY.

<u>NO.</u>	<u>PART NO.</u>	<u>PART NAME</u>	<u>QTY.</u>	<u>REMARKS</u>
1*	37011	PULLEY, 3.3 10 3V 4.5 1A	1	FITS 26", 30", 36" BELT DRIVE
1#	37154	PULLEY, 4.1 3V 4.5 1A	1	FITS 16", 20" BELT DRIVE
2*#	37003	SUPPORT, ENGINE DRIVE BEARING	1	
3*#	37028	BEARING, TAPERED ROLLER NSK #32007XJ	2	
4*#	37090	SPRING, SMALLEY WAVO RW-0162	1	
5*#	37017	FLANGE, ENGINE DRIVE BEARING SUPPORT	1	
6*#	37092	SEAL, CR 17753	2	
7*#	37035	SCREW, SHC 4-40 X 3/8	4	
8*#	915004	SCREW, HHC 1/4 - 20 X 7/8 GR8 YZ	8	
9*#	933240	WASHER, FLAT SAE 1/4 GRD 9 YZ	8	
10	37103	DRIVE PULLEY ASSY., 3.3 10 3V 4.5 1A	1	FITS 26", 30", 36" BELT DRIVE INCLUDES ITEMS W/*
10	37321	DRIVE PULLEY ASSY., 4.1 3V 4.5 1A	1	FITS 16", 20" BELT DRIVE INCLUDES ITEMS W/#

BLADE SHAFT ASSY.

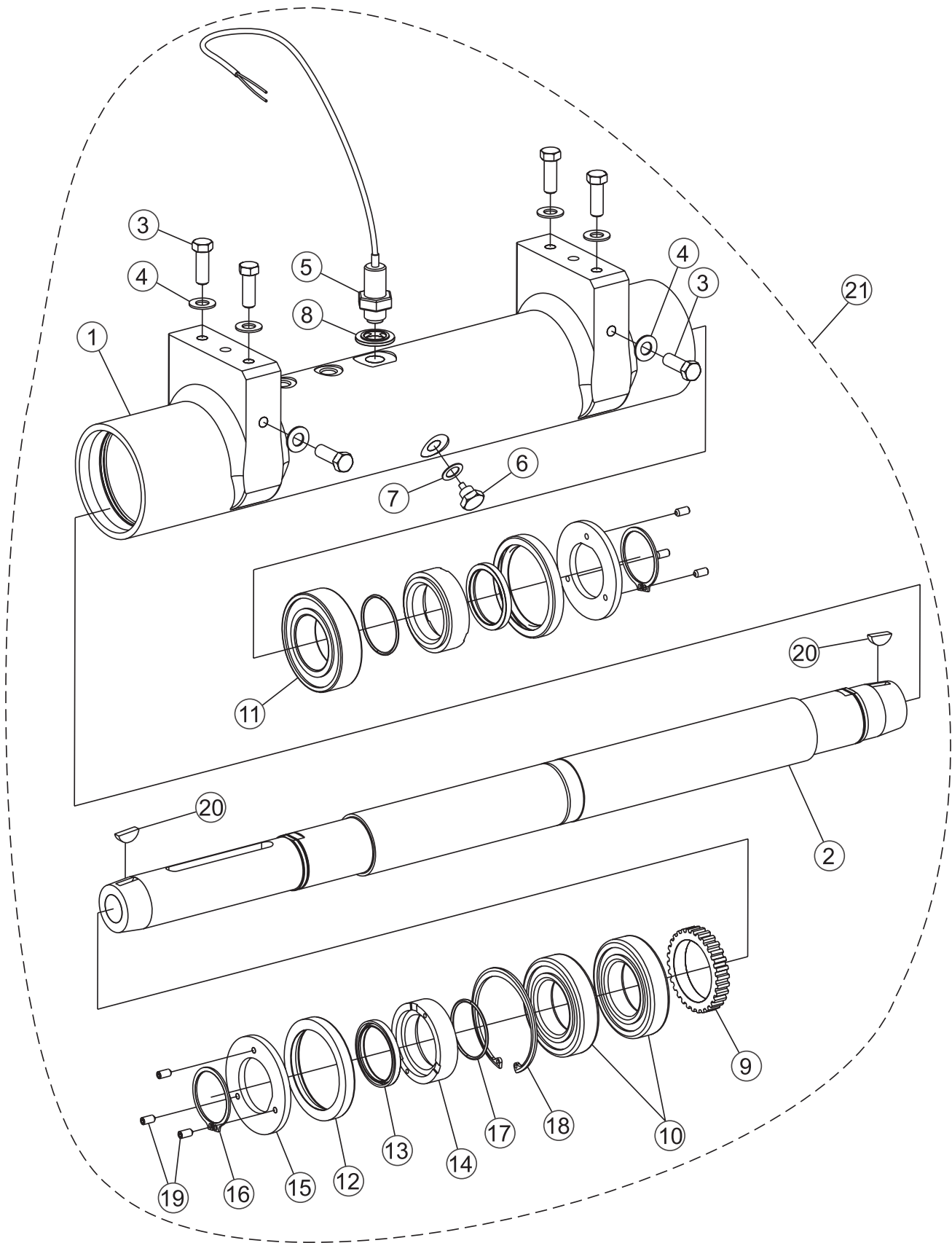

BLADESHAFT ASSY.

BLADE SHAFT ASSY.

<u>NO.</u>	<u>PART NO.</u>	<u>PART NAME</u>	<u>QTY.</u>	<u>REMARKS</u>
1*	37108	HOUSING, BLADESHAFT	1	
2*	37111	BLADESHAFT, 7000 SERIES	1	
3*	06502-010	SCREW, HHC 7/16 - 14 X 1-1/4	6	
4*	933243	WASHER FLAT SAE 7/16 GRD 9 YZ	6	
5*	421001	SENSOR, HALL EFFECT SPEED PICKUP	1	
6*	583026	DRAIN PLUG, MAGNETIC 1/2 - 20	1	
7*	577009	GASKET, DRAIN PLUG	1	
8*	25695	WASHER, SEAL 3/4"	1	
9*	25690	GEAR, SAW BLADE SHAFT SPEED PICKUP	1	
10*	460010	BEARING, ROLLER KOYO # 7210BGC3	2	
11*	39460011	BEARING, BALL KOYO # NU2210RC3	1	
12*	480006	SEAL, OIL CR# 28655	2	
13*	480007	SEAL, OIL CR- 19599	2	
14*	485003	SLEEVE, BLADE SHAFT SEAL	2	
15*	486001	WASHER, THRUST 6000 SERIES	2	
16*	576006	SNAP RING, VITON # AS-135	2	
17*	578135	O-RING, VITON # AS-135	2	
18*	576007	SNAP RING, VHO-354	1	
19*	10138	SCREW, SHS 1/4 - 20 X 1/2	6	
20*	927048	KEY, WOODRUFF #807 1/4 X 7/8	2	
21	37134	BLADESHAFT ASSEMBLY	1	INCLUDES ITEMS W/*

16", 20", 26" BLADEGUARD ASSY.

16", 20", 26" BLADEGUARD ASSY.

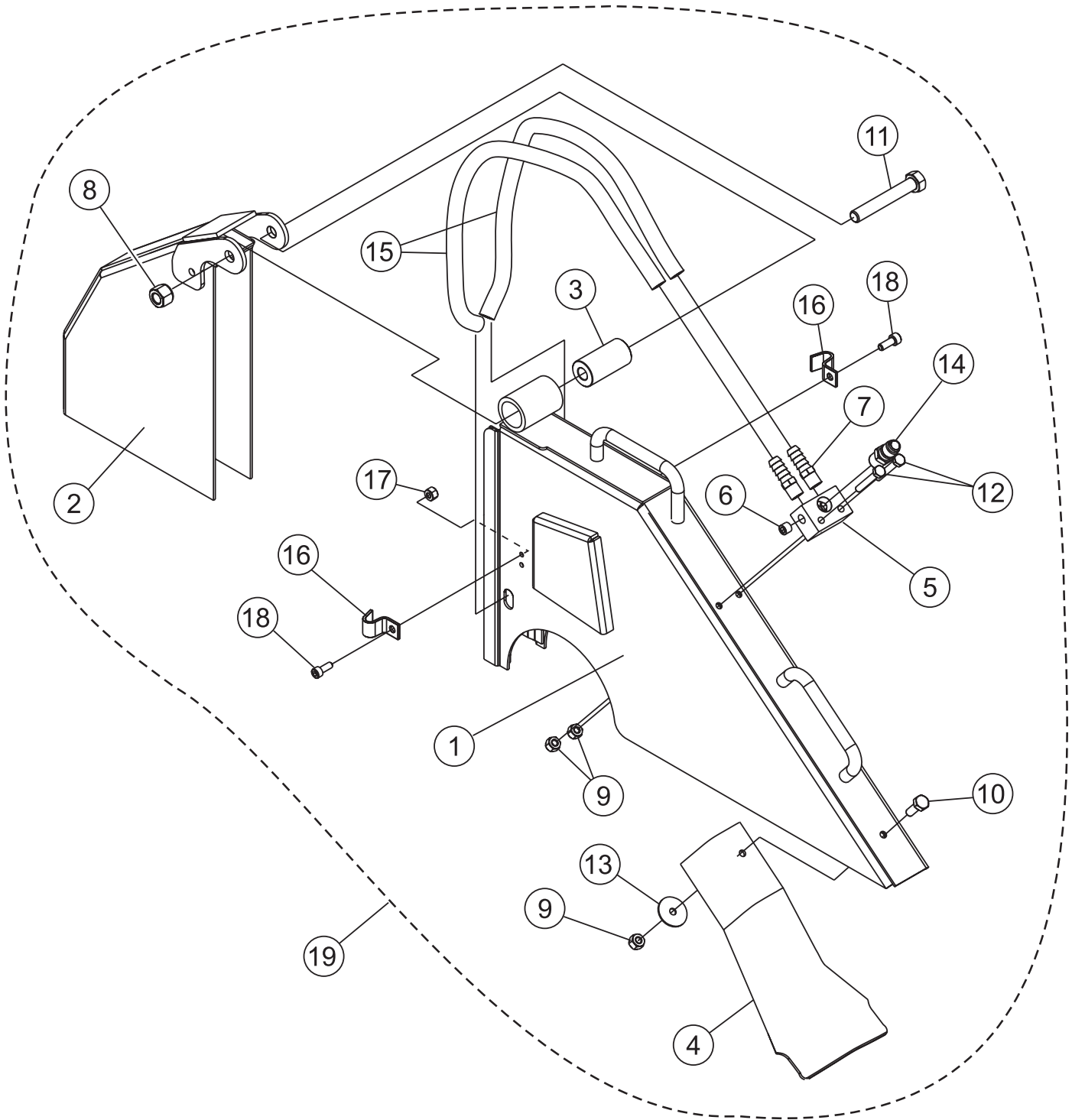

16", 20", 26" BLADEGUARD ASSY.

16", 20", 26" BLADEGUARD ASSY.

<u>NO.</u>	<u>PART NO.</u>	<u>PART NAME</u>	<u>QTY.</u>	<u>REMARKS</u>
1*	200004	BLADEGUARD W/A, 16" REAR HALF	1	
1#	200008	BLADEGUARD W/A, 20" REAR HALF	1	
1\$	200010	BLADEGUARD W/A, 26" REAR HALF	1	
2*	200003	BLADEGUARD W/A, 16" FRONT HALF	1	
2#	200007	BLADEGUARD W/A, 20" FRONT HALF	1	
2\$	200009	BLADEGUARD W/A, 26" FRONT HALF	1	
3*#\$	582040	BUSHING, BLADEGUARD HINGE DELRIN	1	
4*#\$	200019	FLAP,MUD BLADEGUARD	1	SAFETY ITEM
5*#\$	37394	MANIFOLD, WATER SMALL	1	
6*#\$	2113	FITTING, PLUG 1/8MP HEX SKT HD	1	
7*#\$	370456	FITTING, BRASS 6BARB-1/4MP	2	
8*#\$	10176	NUT, NYLOC 1/2-13	1	
9*#\$	10024	NUT, NYLOC 1/4-20	3	
10*#\$	0131 A	SCREW, HHC 1/4 - 20 X 3/4	1	
11*#\$	06503-026	SCREW, HHC 1/2 - 13 X 3-1/4	1	
12*#\$	26250	SCREW, HHC 1/4 - 20 X 1-3/4	2	
13*#\$	10930	WASHER, FENDER 1/4 X 1-1/4	1	
14*#\$	37396	3/8" QC MALE	1	
15*#	37506	HOSE, WATER #6 LP, 16", 20" BLADEGUARD	2	
15\$	37508	HOSE, WATER #6 LP, 26" BLADEGUARD	2	
16*#\$	22129-001	PIPE STRAP 3/8	2	
17*#\$	1618	NUT, NYLOC 10-24	2	
18*#\$	923144	SCREW, SHC 10-24 X 1/2	2	
19	37335	BLADEGUARD ASSY., 16" STD SYS	1	SAFETY ITEM INCLUDES ITEMS W/*
19	37336	BLADEGUARD ASSY., 20" STD SYS	1	SAFETY ITEM INCLUDES ITEMS W/#
19	37337	BLADEGUARD ASSY., 26" STD SYS	1	SAFETY ITEM INCLUDES ITEMS W/\$

30", 36" BLADEGUARD ASSY.

30", 36" BLADE GUARD ASSY.

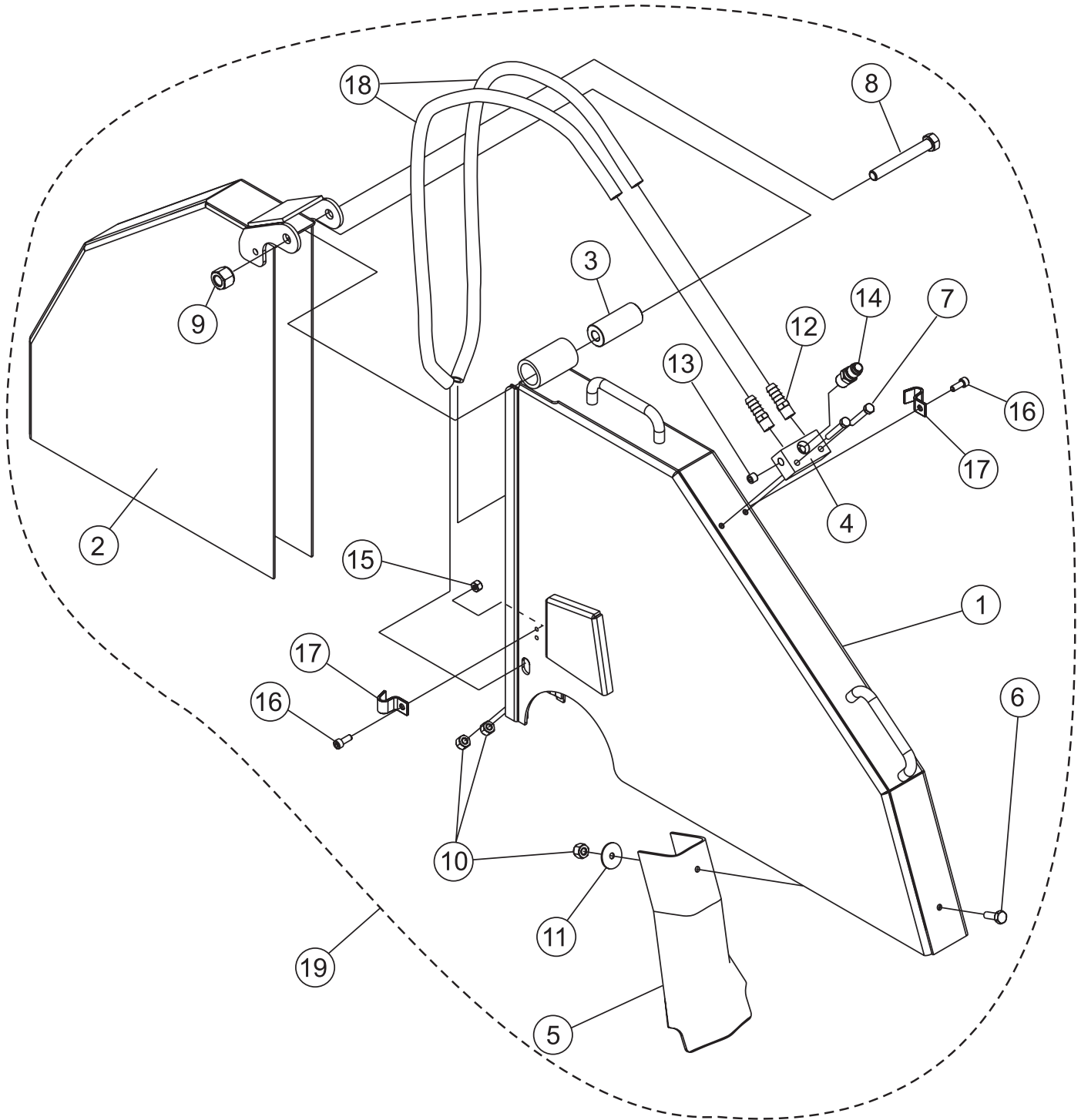

30", 36" BLADEGUARD ASSY.

30", 36" BLADE GUARD ASSY.

<u>NO.</u>	<u>PART NO.</u>	<u>PART NAME</u>	<u>QTY.</u>	<u>REMARKS</u>
1*	200012	BLADEGUARD W/A, 30" REAR HALF	1	
1#	200014	BLADEGUARD W/A, 36" REAR HALF	1	
2*	200011	BLADEGUARD W/A, 30" FRONT HALF	1	
2#	200013	BLADEGUARD W/A, 36" FRONT HALF	1	
3*#	582039	BUSHING, BLADEGUARD HINGE DELRIN	1	
4*#	37395	MANIFOLD, WATER LARGE	1	
5*#	200019	FLAP,MUD BLADEGUARD	1	SAFETY ITEM
6*#	0131 A	SCREW, HHC 1/4 - 20 X 3/4	1	
7*#	26250	SCREW, HHC 1/4 - 20 X 1-3/4	2	
8*#	06503-030	SCREW, HHC 1/2 - 13 X 3-3/4	1	
9*#	10176	NUT, NYLOC 1/2-13	1	
10*#	10024	NUT, NYLOC 1/4-20	3	
11*#	10930	WASHER, FENDER 1/4 X 1-1/4	1	
12*#	370456	FITTING, BRASS 6BARB-1/4MP	2	
13*#	2113	FITTING, PLUG 1/8MP HEX SKT HD	1	
14*#	37396	3/8" QC MALE	1	
15*#	1618	NUT, NYLOC 10-24	2	
16*#	923144	SCREW, SHC 10-24 X 1/2	2	
17*#	22129-001	PIPE STRAP 3/8	2	
18*	37509	HOSE, WATER #6 LP, 30" BLADEGUARD	2	
18#	37510	HOSE, WATER #6 LP, 36" BLADEGUARD	2	
19	37338	BLADEGUARD ASSY., 30" STD SYS	1	SAFETY ITEM
			INCLUDES ITEMS W/*
19	37339	BLADEGUARD ASSY., 36" STD SYS	1	SAFETY ITEM
			INCLUDES ITEMS W/#

OPTIONAL WEIGHT KIT ASSY.

OPTIONAL WEIGHT KIT ASSY.

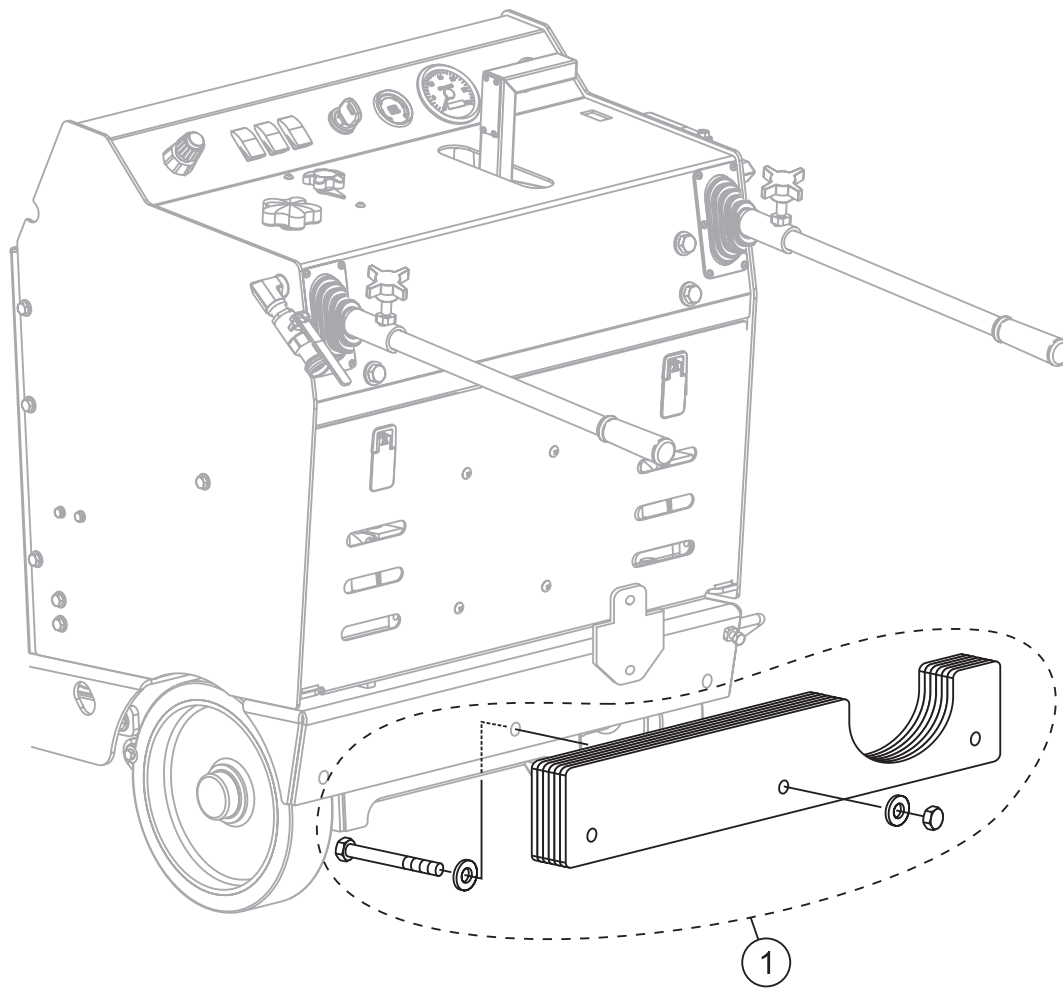

OPTIONAL WEIGHT KIT ASSY.

OPTIONAL WEIGHT KIT ASSY.

<u>NO.</u>	<u>PART NO.</u>	<u>PART NAME</u>	<u>QTY.</u>	<u>REMARKS</u>
1	37829	WEIGHT KIT	1	