

**OPERATION AND PARTS MANUAL**

**STOW**

A DIVISION OF MULTIQUIP INC.

**CMS-94S  
CONCRETE MIXER**

Revision #2 (08/04/06)

# STOW CMS-94S CONCRETE MIXER — TABLE OF CONTENTS

## STOW CMS-94S Concrete Mixer

Here's How To Get Help .....	3
Table Of Contents .....	4
Parts Ordering Procedures .....	5
Specifications .....	6
Dimensions (Mixer) .....	7
Safety Message Alert Symbols .....	8
Rules For Safe Operation .....	9-10
Operation and Safety Decals .....	11
General Information .....	12
Mixer Basic Components .....	13
Basic Engine Components .....	14
Handwheel Assembly .....	15
Towing Guidelines .....	16
Safety Chain Connection .....	17
Electric Motor .....	18-19
Pre-Inspection (Gasoline Engine) .....	20
Initial Start-up (Gasoline Engine) .....	21
Initial Start-up (Electric Motor) .....	22
Operation .....	23
Maintenance (Engine) .....	24-25
Maintenance (Mixer) .....	26-28
Troubleshooting (Engine) .....	30
Troubleshooting (Engine/Mixer) .....	31
Explanation Of Code In Remarks Column .....	32
Suggested Spare Parts .....	33

## Component Drawings

Nameplate and Decals .....	34-35
Mixer Assembly (Steel Drum) .....	36-37
Main Frame Assembly .....	38-39
Axle Assembly .....	40-41
Cabinet Assembly .....	42-43
Gas Engine Mounting Plate Assembly .....	44-45
Electric Motor Mounting Plate Assembly .....	46-47

## HONDA GX240K1QA2 ENGINE

Air Cleaner Assembly .....	48-49
Camshaft Assembly .....	50-51
Carburetor Assembly .....	52-53
Control Assembly .....	54-55
Crankcase Cover Assembly .....	56-57
Crankshaft Assembly .....	58-59
Cylinder Barrel Assembly .....	60-61
Cylinder Head Assembly .....	62-63
Fan Cover Assembly .....	64-65
Flywheel Assembly .....	66-67
Muffler Assembly .....	68-69
Fuel Tank Assembly .....	70-71
Ignition Coil .....	72-73
Piston Assembly .....	74-75
Recoil Starter .....	76-77
Label Assembly .....	78-79
Terms and Conditions of Sale .....	80

# STOW CMS-94S CONCRETE MIXER — OPERATION AND SAFETY DECALS

## Machine Safety Decals

The STOW CMS-94S mixer is equipped with a number of safety decals (Figure 1A). These decals are provided for operator safety and maintenance information. The illustration below and on the next page shows these decals as they appear on the machine. Should any of these decals become unreadable, replacements can be obtained from your dealer.



P/N: 13118



CONTACT MQ PARTS  
DEPARTMENT



P/N: 510164



P/N: DCL151



P/N: DCL160A

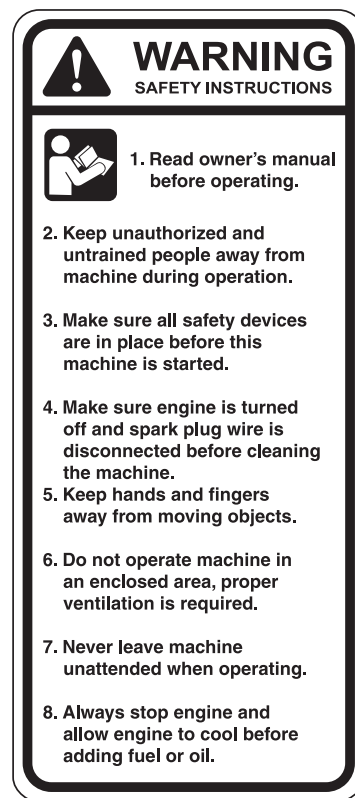

P/N: 504713



P/N: 35137



P/N: EM948630

Figure 1A. STOW CMS-94SMixer Decals

# STOW CMS-94S CONCRETE MIXER — SUGGESTED SPARE PARTS

## STOW CMS-94S CONCRETE MIXER 1 TO 3 UNITS WITH HONDA GX240K1QA2 ENGINE

Qty...	P/N .....	Description
2	493399	V-BELT w/GAS ENGINE
1	502212	V-BELT w/ELECTRIC MOTOR
1	29713-001	STOP SWITCH w/GAS ENGINE
2	491010	LATCH SET
1	505390	EXPANSION PLUG
2	510956	SPINDLE BEARING CUP
2	510955	SPINDLE BEARING CONES
1	EM505472	SPACER, DRUM
2	492179	BEARING PINION
2	EM914288	SEAL, AXLE
4	EM903012	BEARING CUP
4	EM903113	BEARING CONE
2	3469	DUST CAP, AXLE
3	9807956846	SPARK PLUG
3	17210ZE2505	AIR FILTER
1	17620ZH7023	CAP, FUEL
1	28462ZEW211	ROPE

# STOW CMS-94S CONCRETE MIXER — NAME PLATE AND DECALS

## NAME PLATE AND DECALS

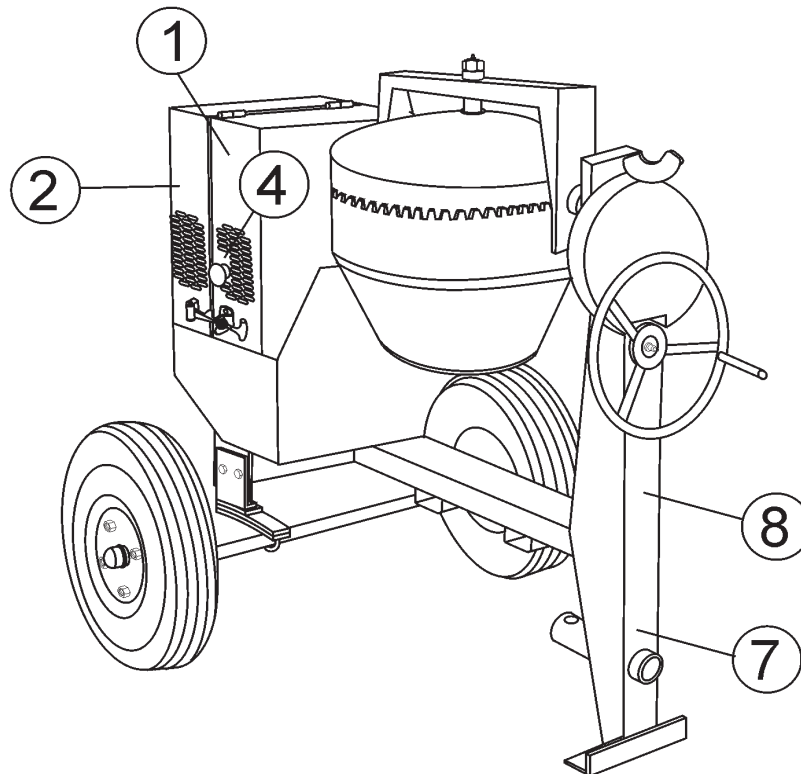
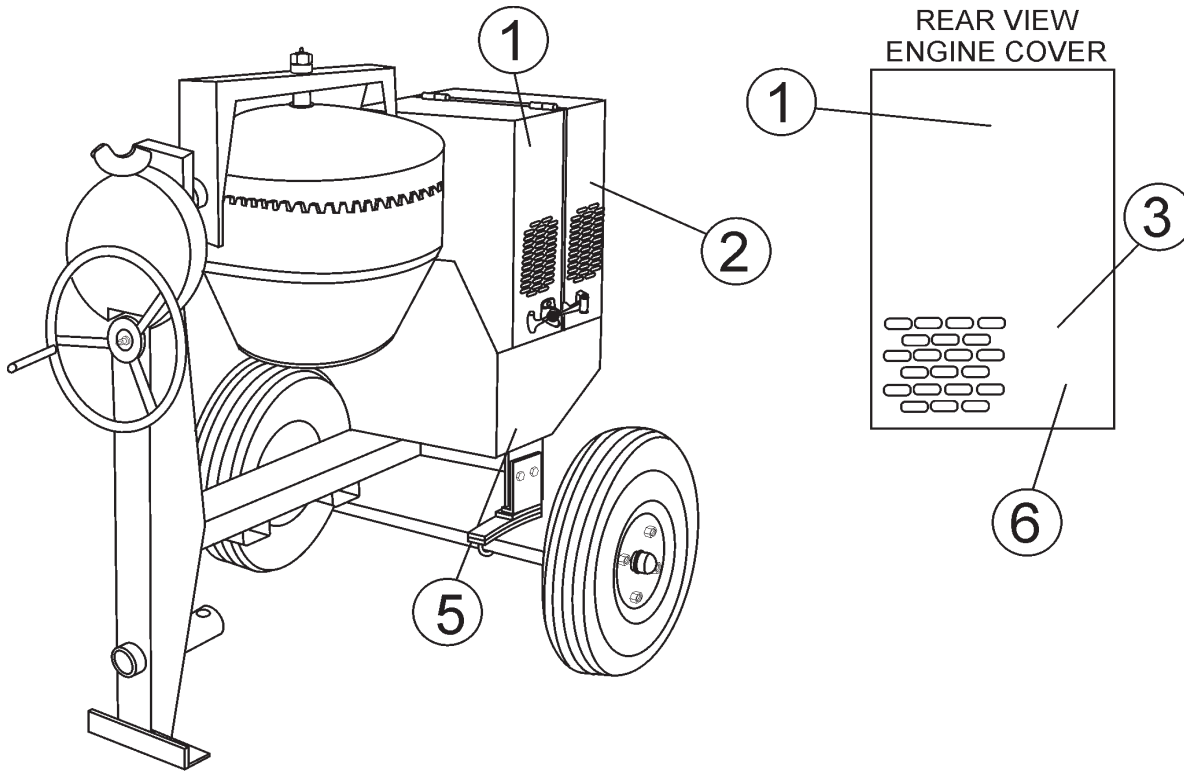

# STOW CMS-94S CONCRETE MIXER— NAME PLATE AND DECALS

## NAME PLATE AND DECALS

<u>NO</u>	<u>PART NO</u>	<u>PART NAME</u>	<u>QTY.</u>	<u>REMARKS</u>
1	510164	STOW LOGO	2	
2	CIPDCL160	DECAL, CRUSH WARNING	2	
3	504713	DECAL, SAFETY INSTRUCTIONS	1	
4	EM948630	DECAL, EMERGENCY STOP	1	
5	DCL151	DECAL, TOWING INSTRUCTIONS	1	
6	35137	DECAL, WARNING READ	1	
7	13118	DECAL, POWDER COATED	1	
8		NAMEPLATE .....	1	..... CONTACT PARTS DEPT.

SEE DECAL ILLUSTRATIONS ON PAGE 11

# STOW CMS-94S CONCRETE MIXER — STEEL BARREL

## STEEL BARREL ASSY.

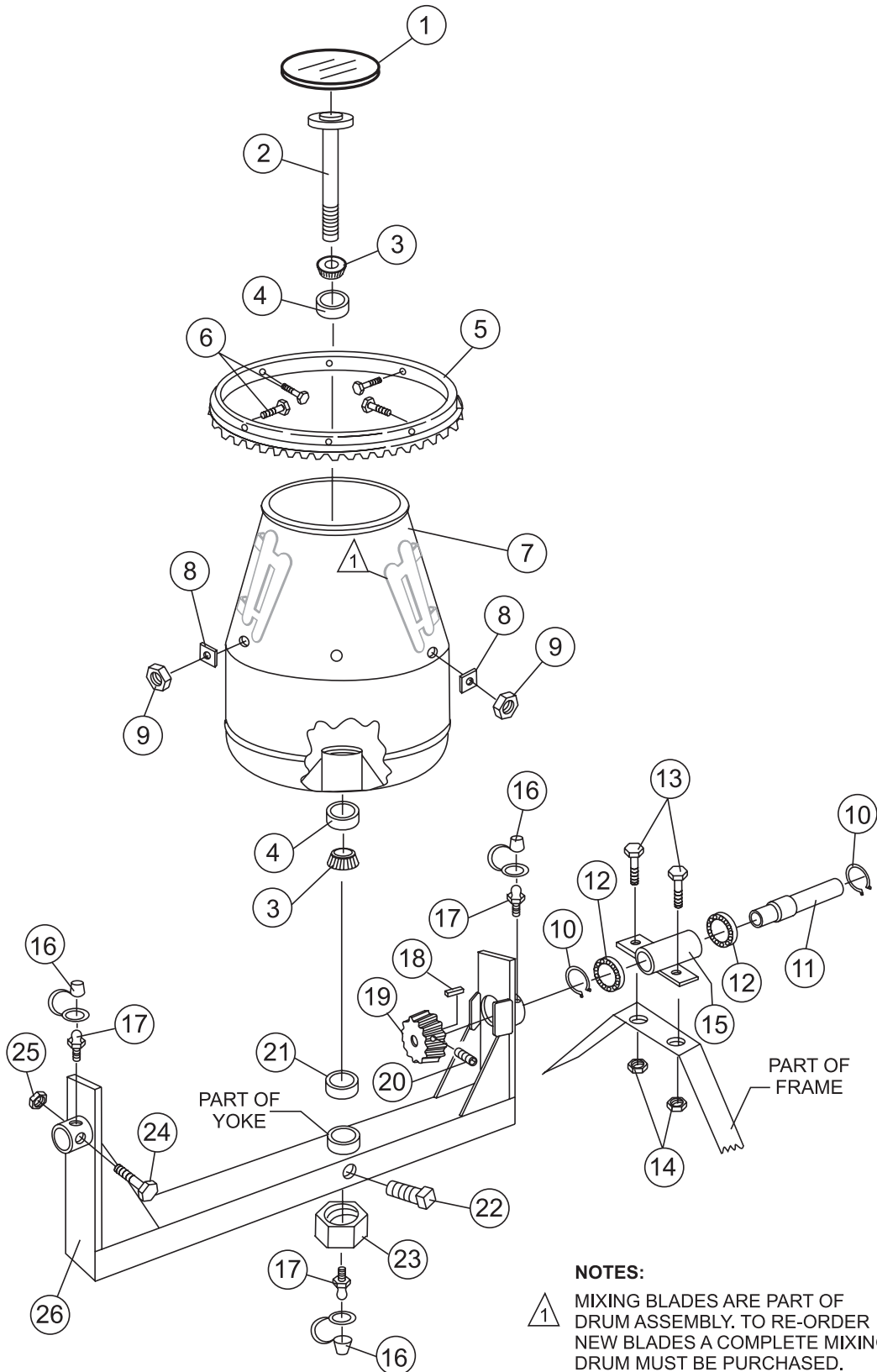

# STOW CMS-94S CONCRETE MIXER — STEEL BARREL

## STEEL BARREL ASSY.

<u>NO</u>	<u>PART NO</u>	<u>PART NAME</u>	<u>QTY.</u>	<u>REMARK</u>
1	505390	PLUG, EXPANSION	1	
2	505469	KING PIN	1	
3	510955	SPINDLE BEARING CONE	2	
4	510956	SPINDLE BEARING CUP	2	
5	514061Y	RING GEAR	1	
6	EM9633057	BOLT 3/8" NC 1-1/2" G5	6	
7	505473Y	BARREL, STEEL 9 CU. FT.	1	
8	511732	SHIM 0.25 THICK	AR	
8	511729	SHIM .100 THICK	AR	
8	511730	SHIM .140 THICK	AR	
8	511731	SHIM .187 THICK	AR	
9	EM969013	NUT, LOCK 3/8" NC	6	
10	490962	SNAP RING	2	
11	514515	DRIVE PINION SHAFT	1	
12	492179	BEARING, PINION SHAFT	2	
13	EM963692	BOLT 1/2" NC X 1-1/2" G5	2	
14	492584	LOCKNUT, HEX 1/2" NC	2	
15	502036Y	HOUSING, JACKSHAFT	1	
16	491008	CAP, GREASE FITTING	3	
17	EM916001	GREASE FITTING 1/8" NPT	3	
18	500214	SQUARE KEY 1/4" X 30 MM	1	
19	503915	DRIVE PINION	1	
20	492467	ALLEN SCREW 5/16 NC 3/8"	1	
21	EM505472	SPACER, BARREL	1	
22	492491	SET SCREW 1/2" X 1" NC	1	
23	EM968306	NUT, HEX LOWER 1-1/2" NF	1	
24	492406	BOLT 5/8" NC X 1-1/2" NC	1	
25	492586	LOCKNUT, HEX 5/8" NC	1	
26	510593Y	YOKE	1	



# STOW CMS-94S CONCRETE MIXER — MAIN FRAME ASSEMBLY

MAIN FRAME ASSY.

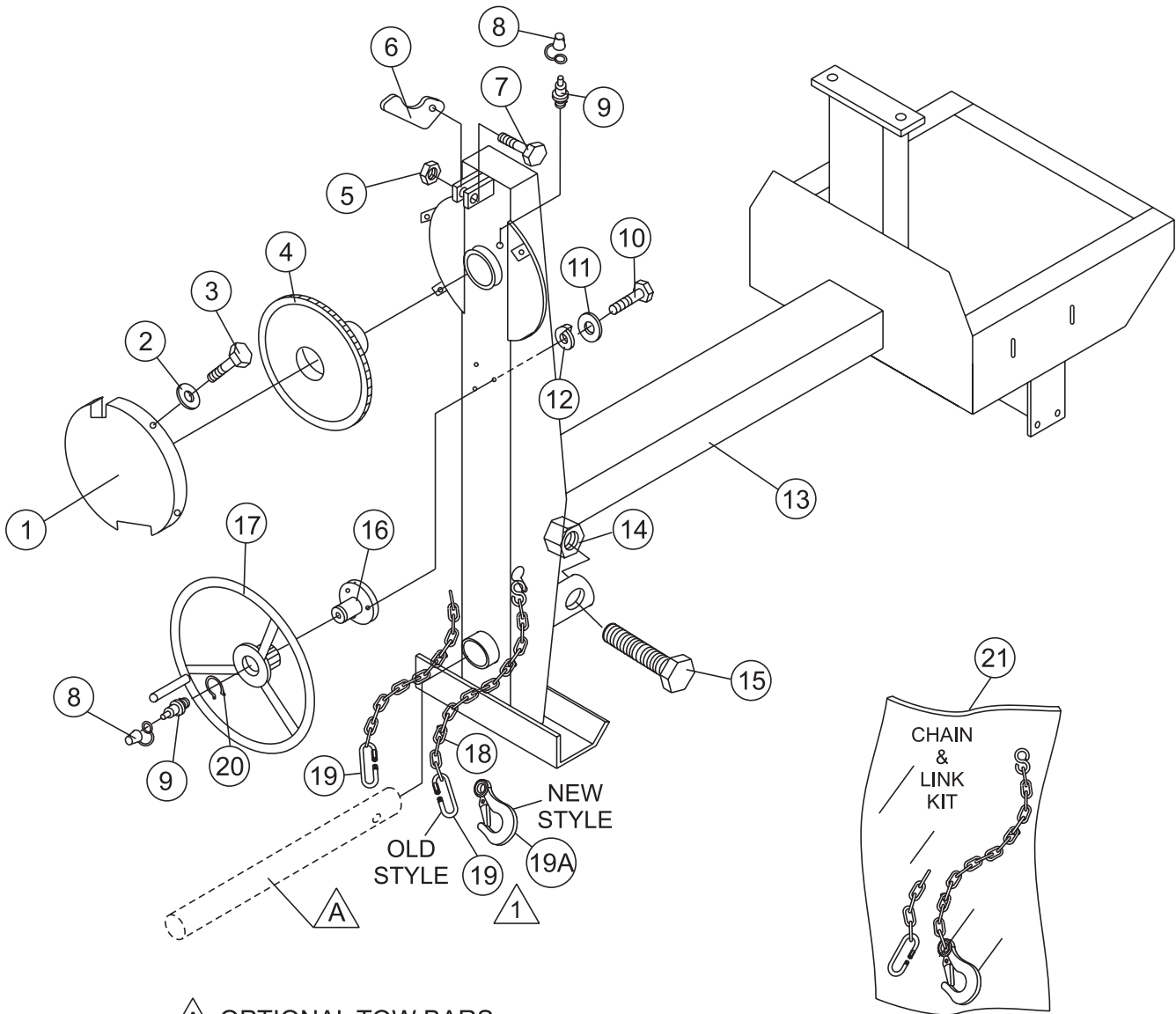

**A** OPTIONAL TOW BARS

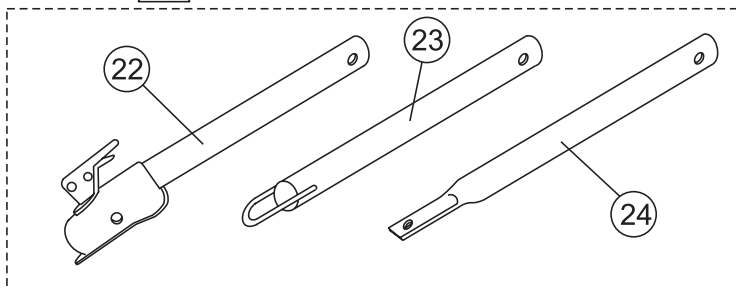

Quantity of item 19, Connector Link, changed from 2 to 1 in January 2006. Item 19A, Clevis Safety Hook, replaces discontinued Connector Link.

**1**

# STOW CMS-94S CONCRETE MIXER — MAIN FRAME ASSEMBLY

## MAIN FRAME ASSY.

<u>NO</u>	<u>PART NO</u>	<u>PART NAME</u>	<u>QTY.</u>	<u>REMARK</u>
1	514245Y	GUARD, GEAR WHEEL	1	
2	492621	WASHER, LOCK 1/4"	4	
3	492278	ROUND HEAD BOLT 1/4" NC 3/8 G2"	4	
4	514692	DUMP GEAR	1	
5	492584	NUT, LOCK 1/2" NC	1	
6	490895Y	DUMP LATCH	1	
7	492395	BOLT 1/2" NC X 1-3/4" G5	1	
8	EM916001	GREASE FITTING 1/8" NPT	2	
9	491008	GREASE CAP	2	
10	EM963055	BOLT 3/8" NC X 3/4" G5	3	
11	3109092	WASHER, FLAT 3/8"	3	
12	0166 A	WASHER, LOCK 3/8"	3	
13	514521Y	FRAME	1	
14	10176	LOCK NUT 1/2 NC	1	
15	EM124	BOLT 1/2"-13 X 4 G5	1	
16	514723	HANDWHEEL SHAFT	1	
17	514002Y	HANDWHEEL	1	
18*		SAFETY CHAIN	1	
19*	01004	CONNECTOR LINK .....	2	BEFORE JANUARY 2006
19*	01004	CONNECTOR LINK .....	1	AFTER JANUARY 2006
19A*	516581	CLEVIS SAFETY HOOK .....	1	AFTER JANUARY 2006
20	490961	SNAP RING	1	
21	13363KIT	CHAIN AND LINK KIT .....	1	INCLUDES ITEMS W/*
22	HBC-1	BALL HITCH 2-INCH .....	1	CONTACT UNIT SALES
23	HLC-1	LOOP HITCH .....	1	CONTACT UNIT SALES
24	HPC-1	PIN HITCH 1-INCH .....	1	CONTACT UNIT SALES

# STOW CMS-94S CONCRETE MIXER — AXLE ASSEMBLY

AXLE ASSY.

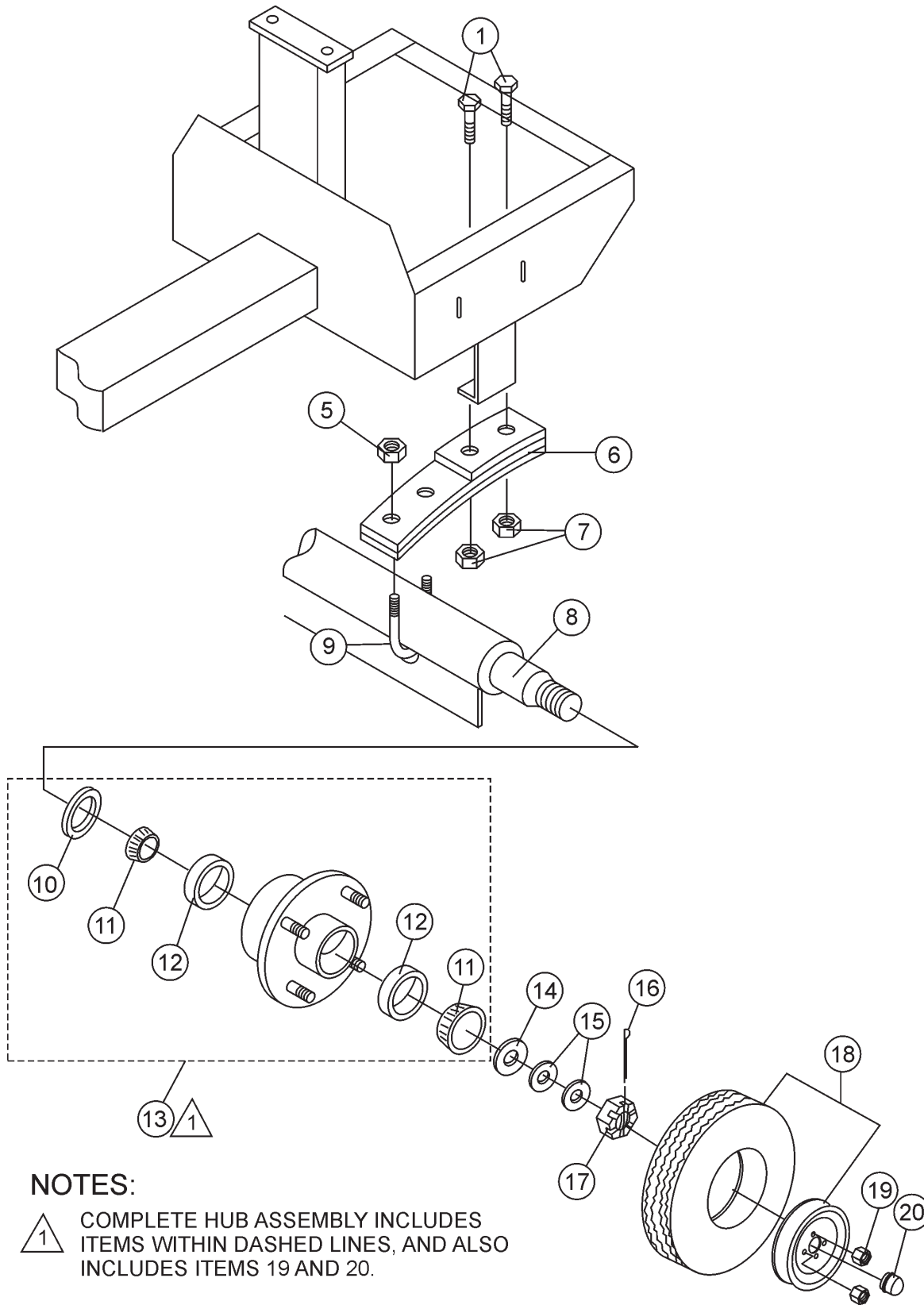

## NOTES:

- △ COMPLETE HUB ASSEMBLY INCLUDES ITEMS WITHIN DASHED LINES, AND ALSO INCLUDES ITEMS 19 AND 20.

# STOW CMS-94S CONCRETE MIXER — AXLE ASSEMBLY

AXLE ASSY.

<u>NO</u>	<u>PART NO</u>	<u>PART NAME</u>	<u>QTY.</u>	<u>REMARK</u>
1	492397	BOLT 1/2" NC 2-1/2" G5	4	
2	EM969023	LOCK NUT 5/8" NC	4	
3	501030	SPRING SUPPORT	2	
4	4922406	BOLT 5/8" NC 1-1/2" G5	4	
5	492589	NUT 1/2" NF	4	
6	491928	SPRING LEAF	2	
7	492584	NUT, HEX 1/2"	4	
8	514545	AXLE	1	
9	500617	U-CLAMP	2	
10#	EM914288	OIL SEAL	2	
11#	EM903113	BEARING CONE	4	
12#	EM903012	BEARING CUP	4	
13	EM941306	HUB ASSY., 4-BOLT (.....)	2	INCLUDES ITEMS W/#
14	511159	WASHER, FLAT, .087" THICKNESS	2	
15	501299	WASHER, FLAT, .135" THICKNESS	AR	
16	491688	COTTER PIN 1/8" X 1-1/2'	2	
17	8164	NUT, SLOTTED HEX JAM 1"-20	2	
18	3005	TIRE AND RIM, CARLISE	2	
19#	8115	LUG NUTS	8	
20#	3469	DUST CAP	2	

# STOW CMS-94S CONCRETE MIXER — CABINET ASSEMBLY

CABINET ASSY.

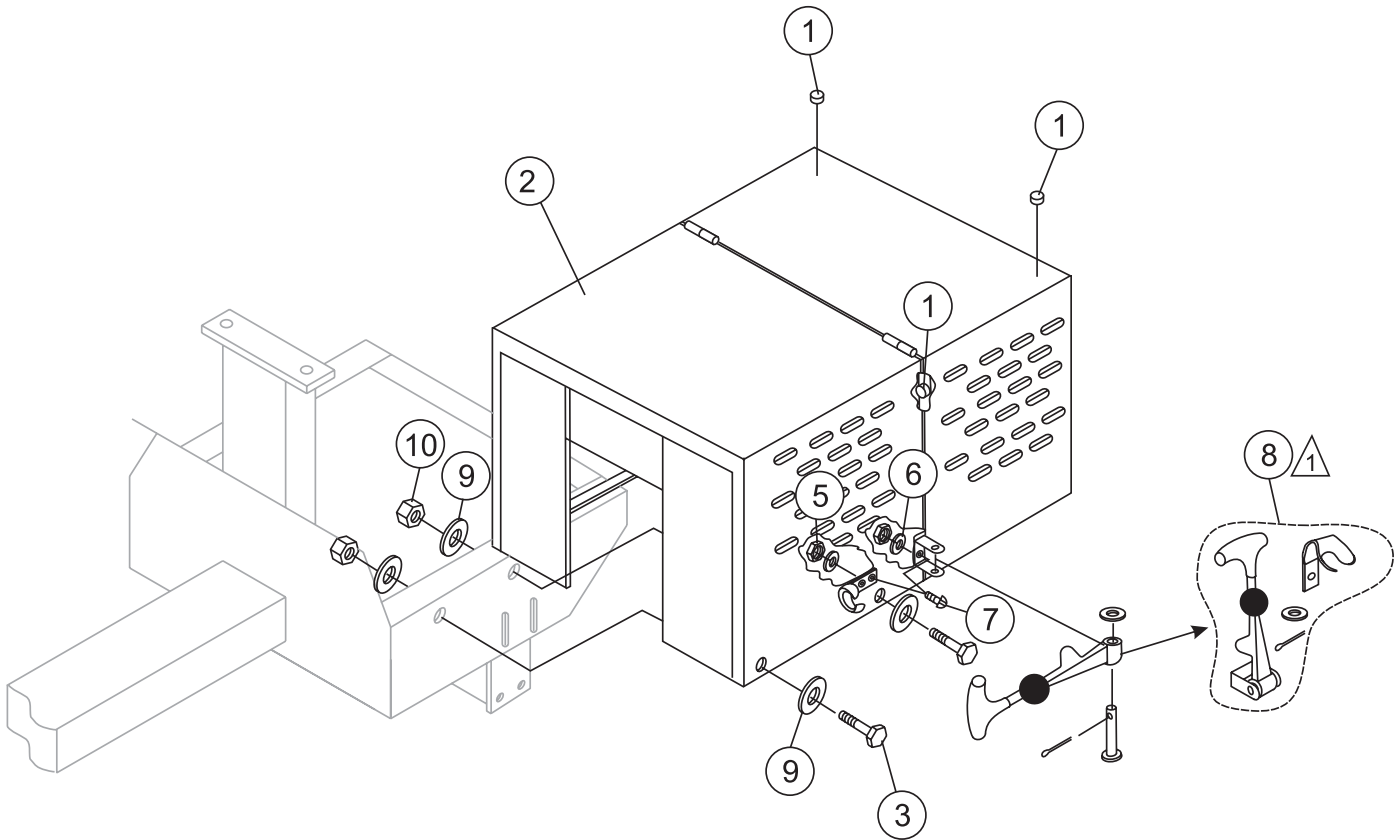

**NOTES:**



COMPLETE LATCH ASSEMBLY  
INCLUDES ITEMS WITHIN DASHED  
LINES. ITEMS CANNOT BE PURCHASED  
SEPARATELY.

# STOW CMS-94S CONCRETE MIXER — CABINET ASSEMBLY

CABINET ASSY.

<u>NO</u>	<u>PART NO</u>	<u>PART NAME</u>	<u>QTY.</u>	<u>REMARKS</u>
1	490202	RUBBER PROTECTOR	4	
2	514694Y	CABINET, ENGINE ASSY. W/DECALS .....	1 .....	INCLUDES ITEM W/*
3	492363	BOLT 5/16" NC X 3/4" G5	4	
4	EM923023	WASHER, FLAT 5/16"	8	
5	13287	LOCK NUT 8-32 .....	6 .....	REPLACEMENT PART ONLY
6	2203	WASHER, FLAT #10 .....	6 .....	REPLACEMENT PART ONLY
7	1307	RHMS 8-32 X 1/2" .....	6 .....	REPLACEMENT PART ONLY
8*	491010	LATCH ASSY., COMPLETE	2	
9	EM923343	WASHER, LOCK 5/16"	4	
10	2105164	NUT 5/16" NC G5	4	
11	RAL1003S	PAINT, SPRAY CAN 12 OZ., YELLOW	AR	
12	RAL1003G	PAINT, GALLON CAN, YELLOW	AR	

# STOW CMS-94S— GAS ENGINE MOUNTING PLATE ASSEMBLY

GAS ENGINE MOUNTING PLATE ASSY.

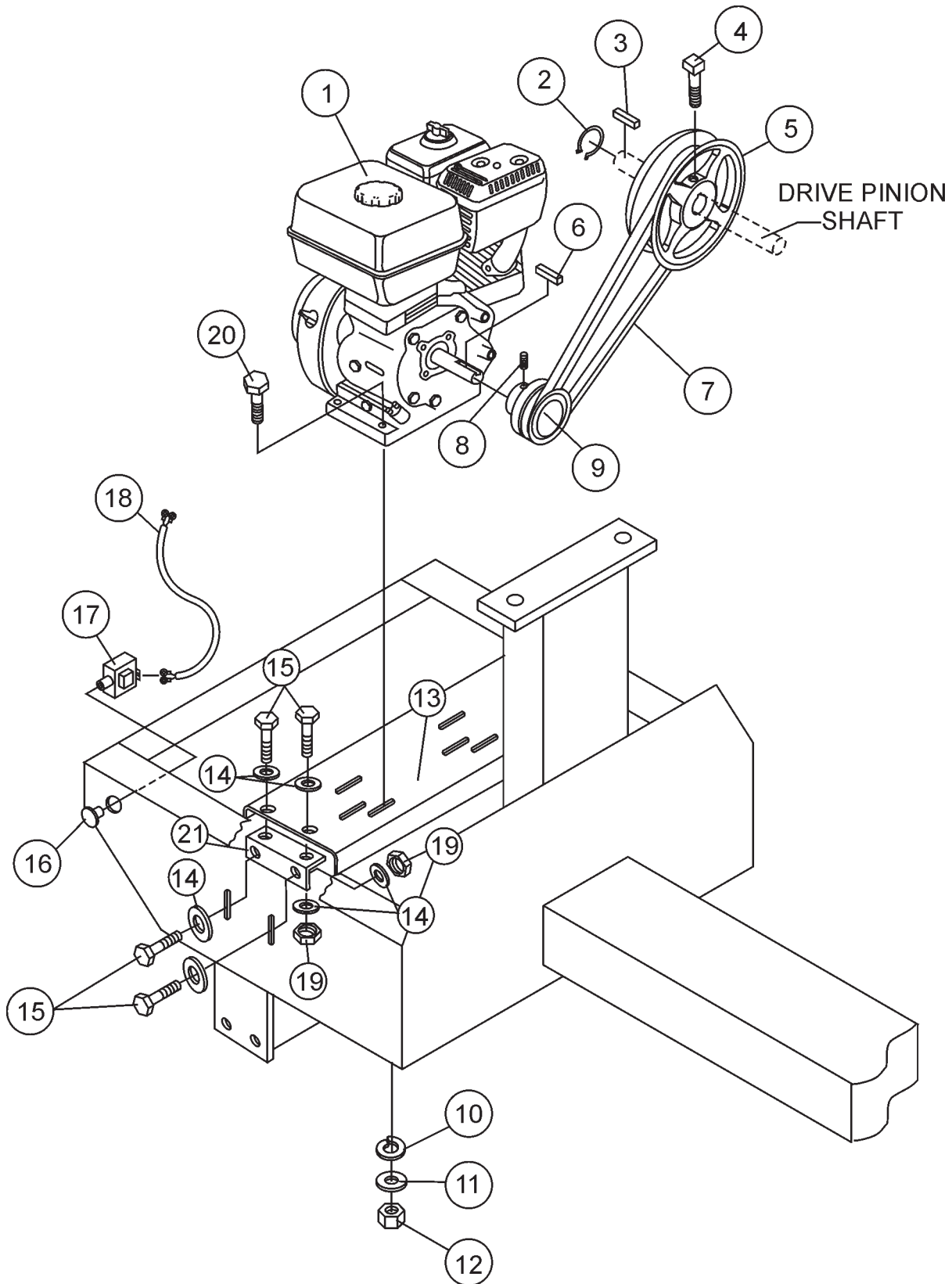

# STOW CMS-94S— GAS ENGINE MOUNTING PLATE ASSEMBLY

## GAS ENGINE MOUNTING PLATE ASSY.

<u>NO</u>	<u>PART NO</u>	<u>PART NAME</u>	<u>QTY.</u>	<u>REMARKS</u>
1	GX240K1QA2	ENGINE, HONDA 8.0 HP	1	
2	490956	SNAP RING	1	
3	500275	SQUARE KEY 1/4 X 40 MM	1	
4	492476	SET SCREW 5/16" NC X 3/4"	1	
5	514060	UPPER PULLEY	1	
6	90745ZE2600	SQUARE KEY 6.3 X 6.3 X 43 MM 8.0 HP	1	
7	493399	V-BELT B-55 8.0 HP	1	
8	492468	ALLEN SCREW 5/16" NC X 3/8"	1	
9	504075	DRIVE PULLEY 8.0 HP	1	
10	EM923343	WASHER, LOCK 5/16"	4	
11	EM923023	WASHER, FLAT 5/16"	4	
12	2105164	NUT, HEX 5/16 X18 NC G5	4	
13	514810	BASE PLATE, ENGINE	1	
14	492600	WASHER, FLAT 1/2"	8	
15	EM963692	BOLT, HEX 1/2" NC 1-1/2" G5	4	
16	29174-001	BUTTON, STOP	1	
17	29173-001	SWITCH, STOP	1	
18	510573C	ENGINE CABLE HARNESS	1	
19	492584	LOCKNUT 1/2"	4	
20	492367	BOLT 5/16" X 1-3/4" G5	4	
21	514656	SUPPORT BRACKET	1	



# STOW CMS-94S— ELECTRIC MOTOR MOUNTING PLATE ASSEMBLY

ELECTRIC MOTOR MOUNTING PLATE ASSY.

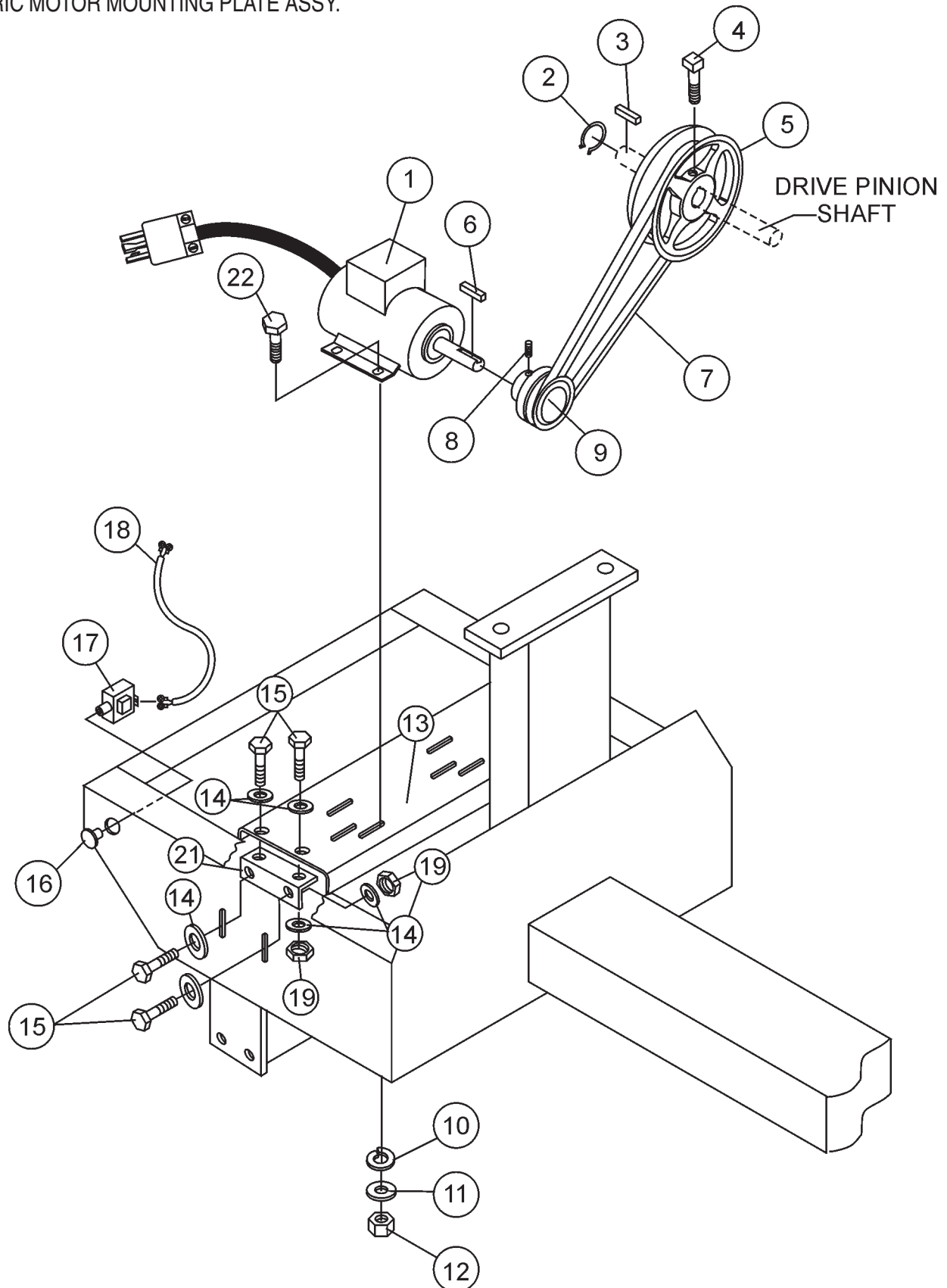

# STOW CMS-94S— ELECTRIC MOTOR MOUNTING PLATE ASSEMBLY

## ELECTRIC MOTOR MOUNTING PLATE ASSY.

<u>NO</u>	<u>PART NO</u>	<u>PART NAME</u>	<u>QTY.</u>	<u>REMARKS</u>
1	P145K17DB45A	MOTOR, ELECTRIC 1.5 HP	1	
2	490960	SNAP RING	1	
3	500275	SQUARE KEY 1/4" X 40 MM	1	
4	492476	SET SCREW 5/16" NC X 3/4"	1	
5	514060	UPPER PULLEY	1	
6	500169	SQUARE KEY 3/16" X 50 MM	1	
7	EM900267	V-BELT B-59	1	
8	492468	ALLEN SCREW 5/16" NC X 1/2"	1	
9	514923	LOWER PULLEY	1	
10	EM923343	WASHER, LOCK 5/16"	4	
11	EM923023	WASHER, FLAT 5/16"	4	
12	2105164	NUT, HEX 5/16 X18 NC G5	4	
13	514810	BASE PLATE, ENGINE	1	
14	492600	WASHER, FLAT 1/2"	8	
15	EM963692	BOLT, HEX 1/2" NC 1-1/2" G5	4	
16	29174-001	BUTTON, STOP	1	
17	29173-001	SWITCH, STOP	1	
18	510573C	ENGINE CABLE HARNESS	1	
19	492584	LOCKNUT 1/2"	4	
20	492367	BOLT 5/16" X 1-3/4" G5	4	
21	514656	SUPPORT BRACKET	1	
22	0202	5/16" X 1" G5	4	

# HONDA GX240K1QA2 ENGINE — AIR CLEANER ASSY.

AIR CLEANER ASSY.

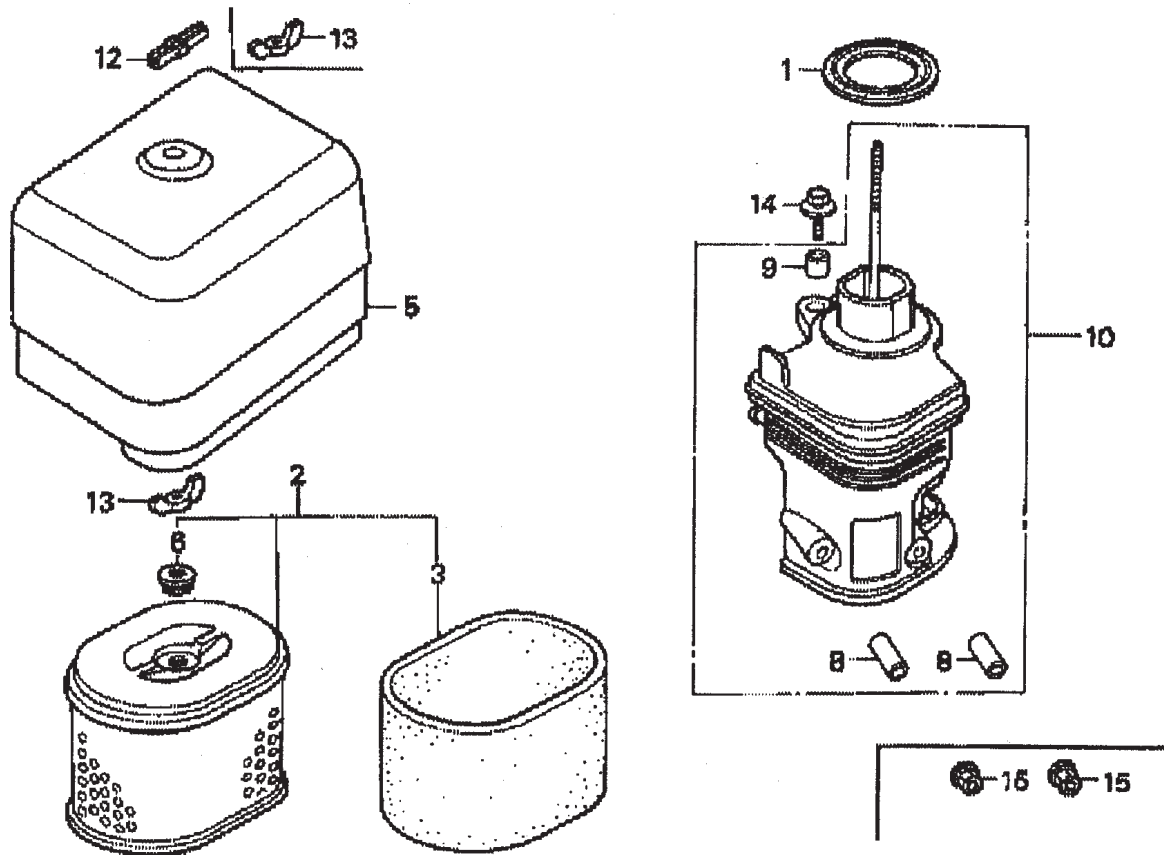

# HONDA GX240K1QA2 ENGINE — AIR CLEANER ASSY.

AIR CLEANER ASSY.

<u>NO.</u>	<u>PART NO.</u>	<u>PART NAME</u>	<u>QTY.</u>	<u>REMARKS</u>
1	16271ZE2000	GASKET, ELBOW .....	1 .....	INCLUDES ITEM W/*
2	17210ZE2515	ELEMENT, AIR CLEANER, DUAL	1	
3 *	17218ZE2505	FILTER, OUTER	1	
5	17231ZH9820	COVER, AIR CLEANER	1	
6	17232891000	GROMMET, AIR CLEANER	1	
8 #	17238ZE2310	COLLAR, AIR CLEANER	2	
9 #	17239ZE1000	COLLAR B, AIR CLEANER	1	
10	17410ZE2020	ELBOW COMP., AIR CLEANER .....	1 .....	INCLUDES ITEM W/#
12	0037806000	WINGNUT 6MM	1	
13	90325044000	WINGNUT, TOOL BOX SETTING	2	
14	90009ZE2003	BOLT- WASHER 6 X 22	1	
15	9405006000	NUT, FLANGE 6MM	2	

# HONDA GX240K1QA2 ENGINE — CAMSHAFT ASSY.

CAMSHAFT ASSY.

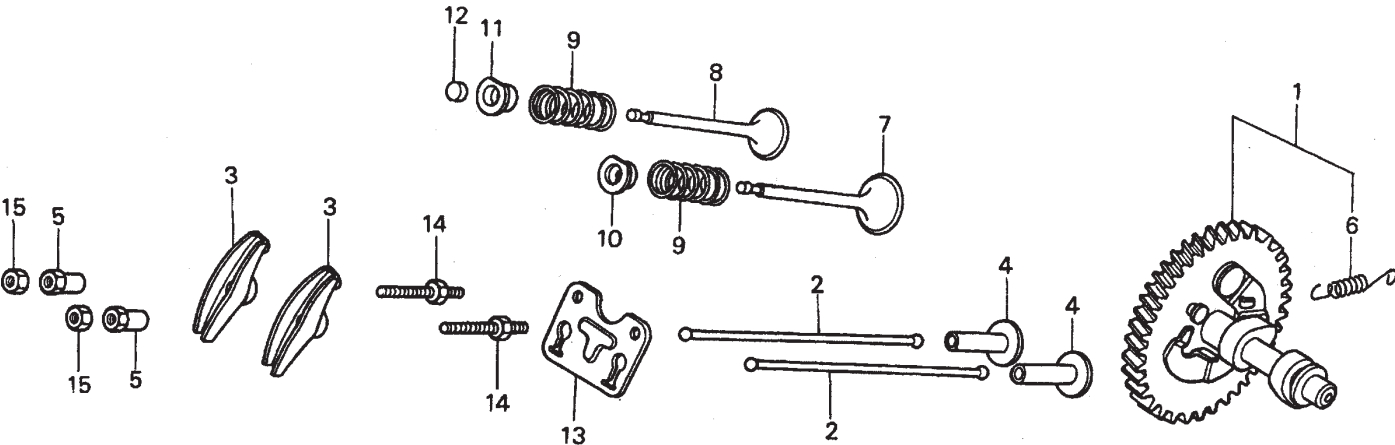

# HONDA GX240K1QA2 ENGINE — CAMSHAFT ASSY.

## CAMSHAFT ASSY.

<u>NO.</u>	<u>PART NO.</u>	<u>PART NAME</u>	<u>QTY.</u>	<u>REMARKS</u>
1	14100ZE2W01	CAMSHAFT ASSY. ....	1	INCLUDES ITEM W/*
1	14100ZE2306	CAMSHAFT	1	
2	14410ZE2013	ROD PUSH	2	
3	14431ZE2010	ARM VALVE ROCKER	2	
4	14441ZE2000	LIFTER VALVE	2	
5	14451ZE1013	PIVOT ROCKER ARM	2	
6*	14568ZE1000	SPRING, WEIGHT RETURN	1	
7	14711ZE2000	VALVE, IN.	1	
8	14721ZE2000	VALVE, EX.	1	
9	14751ZE2003	SPRING, VALVE	2	
10	14771ZE2000	RETAINER, IN. VALVE SPRING	1	
11	14773ZE2000	RETAINER, EX. VALVE SPRING	1	
12	14781ZE2000	ROTATOR, VALVE	1	
13	14791ZE2010	PLATE, PUSH ROD GUIDE	1	
14	90012ZE0010	BOLT, PIVOT 8MM	2	
15	90206ZE1000	NUT, PIVOT ADJ.	2	

# HONDA GX240K1QA2 ENGINE — CARBURETOR ASSY.

CARBURETOR ASSY.

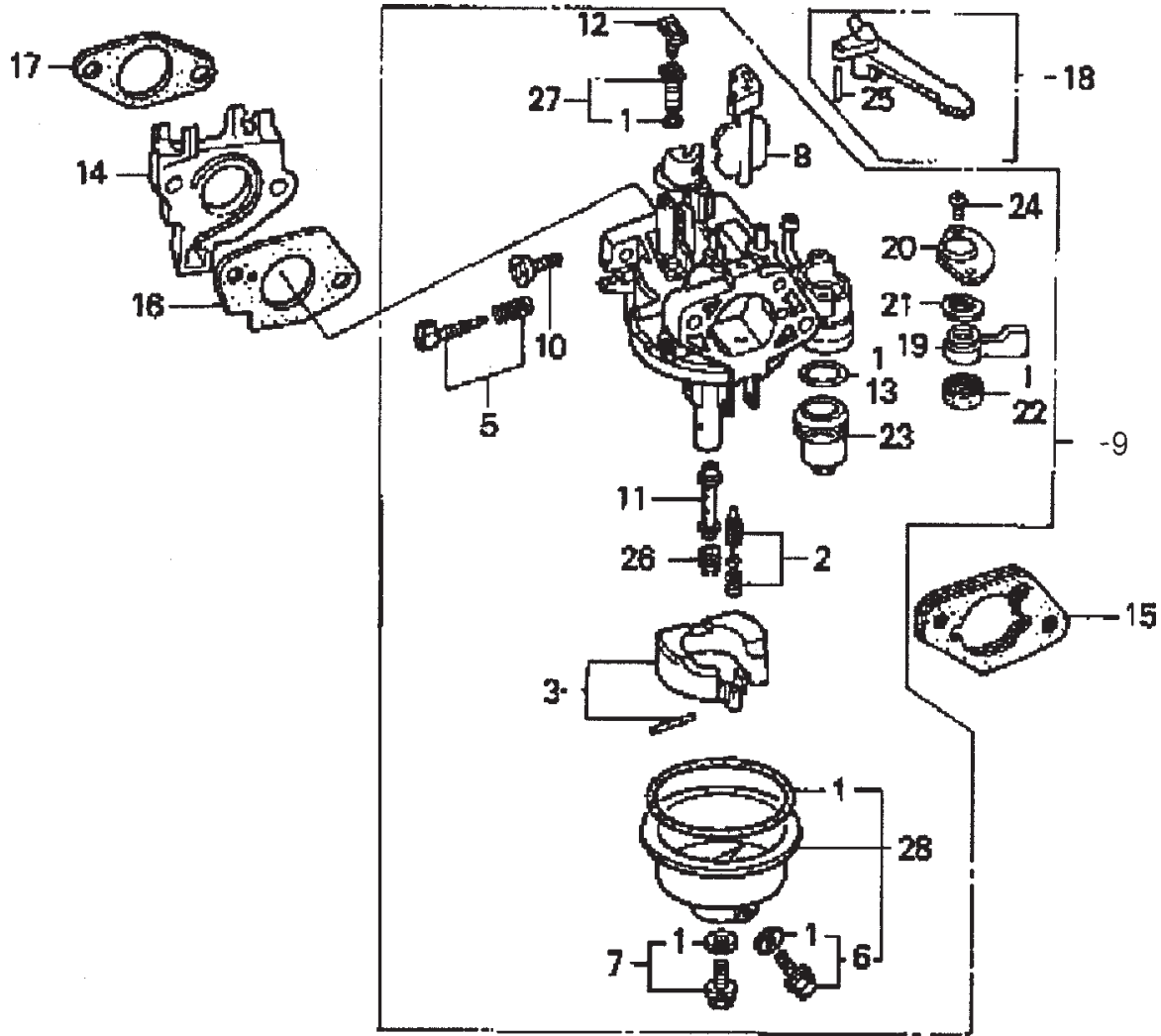

# HONDA GX240K1QA2 ENGINE — CARBURETOR ASSY.

## CARBURETOR ASSY.

<u>NO.</u>	<u>PART NO.</u>	<u>PART NAME</u>	<u>QTY.</u>	<u>REMARKS</u>
1*+	16010ZE2812	GASKET SET	1	
2*	16011ZA0931	VALVE SET, FLOAT	1	
3*	16013ZA0931	FLOAT SET	1	
5*	16016ZHW01	SCREW SET	1	
6*+	16024ZE1811	SCREW SET, DRAIN	1	
7*+	16028ZE0005	SCREW SET B	1	
8*	16028ZE2005	CHOKE SET	1	
9*	16100ZE2W71	CARBURETOR ASSY.....	1	..... INCLUDES ITEMS W/*
10*	16124ZE0005	SCREW, THROTTLE STOP	1	
11*	16166ZE2W70	NOZZLE, MAIN	1	
12*	16172ZE3W10	COLLAR, SET	1	
13*	16075GHBB00	O-RING	1	
14	16211ZE2000	INSULATOR, CARB.	1	
15	16220ZA0702	SPACER COMP., CARB.	1	
16	16221ZA0800	GASKET, CARBURETOR	1	
17	16223ZA0800	GASKET, INSULATOR	1	
18	16610ZE1000	LEVER COMP., CHOKE, STD.	1	
19*	16953ZE1812	LEVER, VALVE	1	
20*	16954ZE1811	PLATE, LEVER SETTING	1	
21*	16956ZE1811	SPRING, VALVE LEVER	1	
22*	16957ZE1812	GASKET, VALVE	1	
23*	16967ZE0811	CUP, FUEL STRAINER	1	
24*	93500030060H	SCREW, PAN 3 X 6	2	
25	9430520122	PIN, SPRING 2 X 12	1	
26*	99101ZH70820	JET, MAIN #82, OPTIONAL	1	
26*	99101ZH70850	JET, MAIN #85, OPTIONAL	1	
26*	99101ZH80880	JET, MAIN #88	1	
27*	99204ZE20400	JET SET, PILOT #40	1	
28*	16015ZE8005	CHAMBER SET, FLOAT .....	1	..... INCLUDES ITEMS W/+



# HONDA GX240K1QA2 ENGINE — CONTROL ASSY.

CONTROL ASSY.

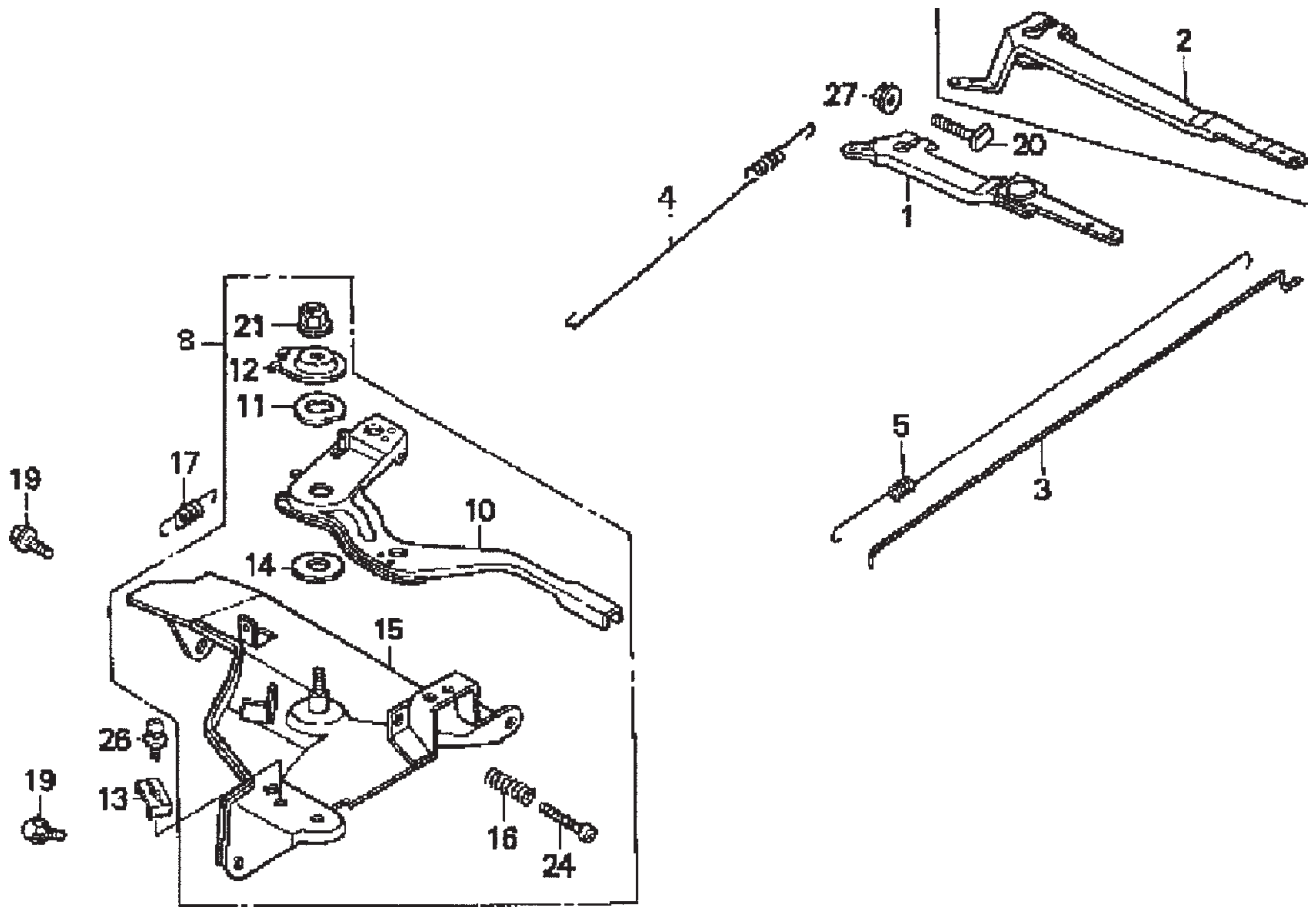

# HONDA GX240K1QA2 ENGINE — CONTROL ASSY.

CONTROL ASSY.

<u>NO.</u>	<u>PART NO.</u>	<u>PART NAME</u>	<u>QTY.</u>	<u>REMARKS</u>
2	16551ZE2000	ARM, GOVERNOR	1	
3	16555ZE2000	ROD, GOVERNOR	1	
4	16561ZE2000	SPRING, GOVERNOR	1	
5	16571ZE2000	SPRING, THROTTLE RETURN	1	
8	16570ZE2W20	CONTROL ASSEMBLY .....	1	INCLUDES ITEMS W/*
10*	16571ZE2W00	LEVER, CONTROL	1	
11*	16574ZE1000	SPRING, LEVER	1	
12*	16575ZE2W00	WASHER, CONTROL LEVER	1	
13	16576891000	HOLDER, CABLE		
14*	16578ZE1000	SPACER, CONTROL LEVER	1	
15*	16581ZE2W00	BASE, CONTROL	1	
16*	16584883300	SPRING, CONTROL ADJUSTING	1	
17	16592883310	SPRING, CABLE RETURN	1	
19	90013883000	BOLT, FLANGE (6 X 12) (CT200)	2	
20	90015ZE5010	BOLT, GOVERNOR ARM	1	
21*	90114SA0000	NUT, SELF- LOCK (6MM)	1	
24*	93500050280A	SCREW, PAN (5 X 28)	1	
26	93500050160A	SCREW, PAN (5 X 16)	1	
27	9405006000	NUT, FLANGE	1	

# HONDA GX240K1QA2 ENGINE — CRANKCASE COVER ASSY.

CRANKCASE COVER ASSY.

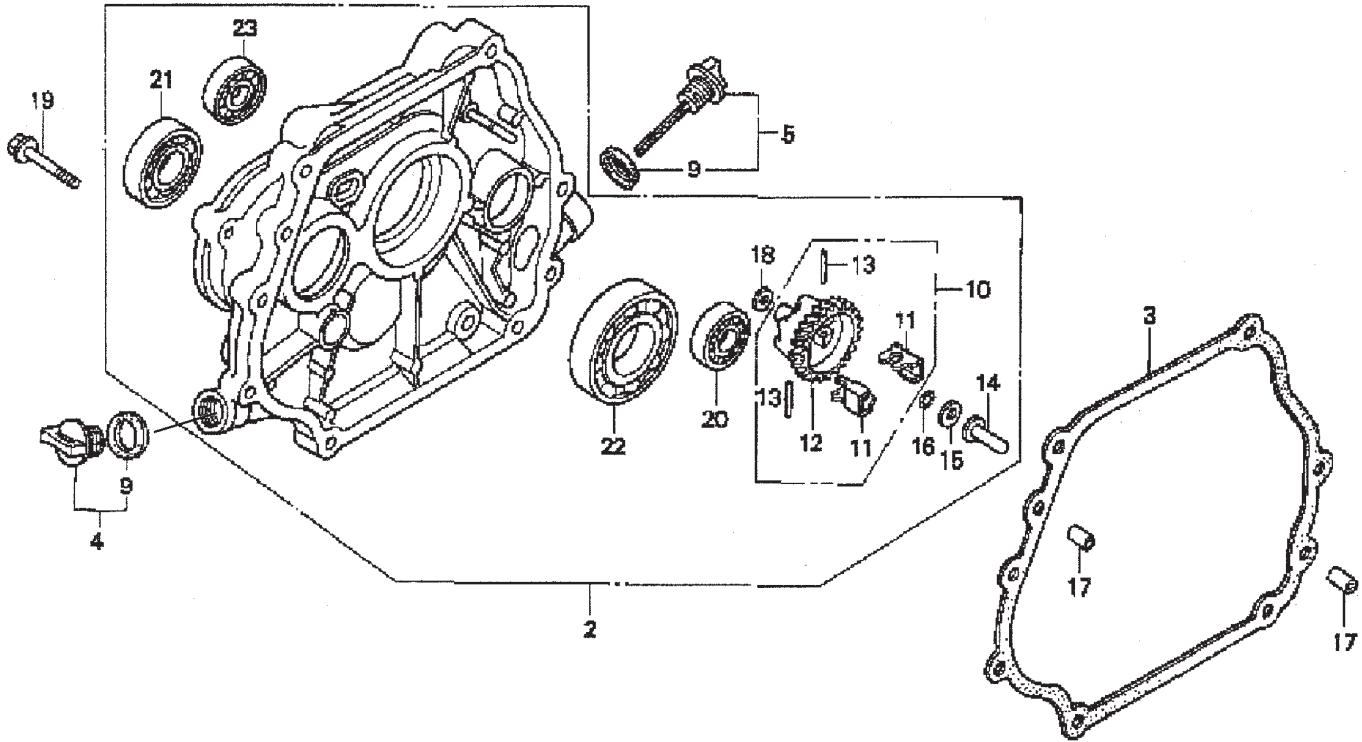

# HONDA GX240K1QA2 ENGINE — CRANKCASE COVER ASSY.

## CRANKCASE COVER ASSY.

<u>NO.</u>	<u>PART NO.</u>	<u>PART NAME</u>	<u>QTY.</u>	<u>REMARKS</u>
2	11400ZE2601	COVER ASSY., CRANKCASE ..... (Q- TYPE) (BALANCER)	1 .....	INCLUDES ITEMS W/*
3	11381ZE2801	GASKET, CASE COVER	1	
4	15600ZG4003	CAP ASSY., OIL FILLER .....	1 .....	INCLUDES ITEMS W/#
5	15600735003	CAP ASSY., OIL FILLER .....	1 .....	INCLUDES ITEMS W/#
9#	15625ZE1003	GASKET, OIL FILLER CAP	1	
10	16510ZE2811	GOVERNOR ASSEMBLY (BALANCER) .....	1 .....	INCLUDES ITEMS W/+
11*+	16511ZE2000	WEIGHT, GOVERNOR	2	
12*+	16512ZE2811	HOLDER, GOVERNOR WEIGHT	1	
13*+	16513ZE2000	PIN, GOVERNOR WEIGHT	2	
14*	16531ZE2000	SLIDER, GOVERNOR	1	
15*	90473147000	WASHER (6 X 16)	1	
16*	90602ZE1000	CLIP, GOVERNOR HOLDER	1	
17	90701HC4000	PIN, DOWEL (8 X 12)	2	
18*	58176	WASHER, PLAIN (6MM)	1	
19	957010803500	BOLT, FLANGE (8 X 35)	7	
20*	961006202000	BEARING, RADIAL BALL (6202)	1	
21*	961006204000	BEARING, RADIAL BALL (6204)	1	
22*	961006206000	BEARING, RADIAL BALL (6206)	1	
23*	961006302000	BEARING, RADIAL BALL (6302)	1	

# HONDA GX240K1 HA2ENGINE — CRANKSHAFT ASSY.

CRANKSHAFT ASSY.

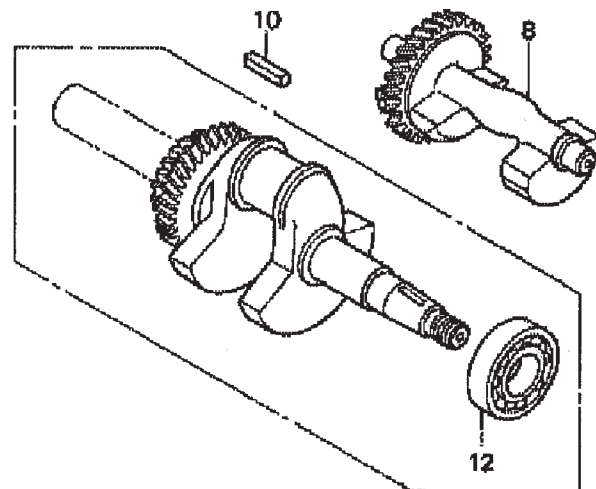
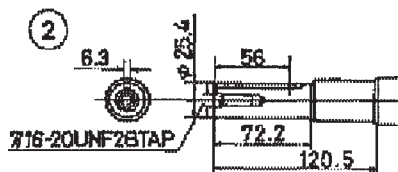

# HONDA GX240K1QA2 ENGINE — CRANKSHAFT ASSY.

CRANKSHAFT ASSY.

<u>NO.</u>	<u>PART NO.</u>	<u>PART NAME</u>	<u>QTY.</u>	<u>REMARKS</u>
2	13320ZE2601	CRANKSHAFT (Q-TYPE) .....	1 .....	INCLUDES ITEM W/*
8	13351ZE2010	WEIGHT BALANCER	1	
10	90745ZE2600	KEY 6.3 X 6.3 X 43 MM	1	
12*	961006206000	BEARING, RADIAL BALL (6206)	1	

# HONDA GX240K1QA2 ENGINE — CYLINDER BARREL ASSY.

CYLINDER BARREL ASSY.

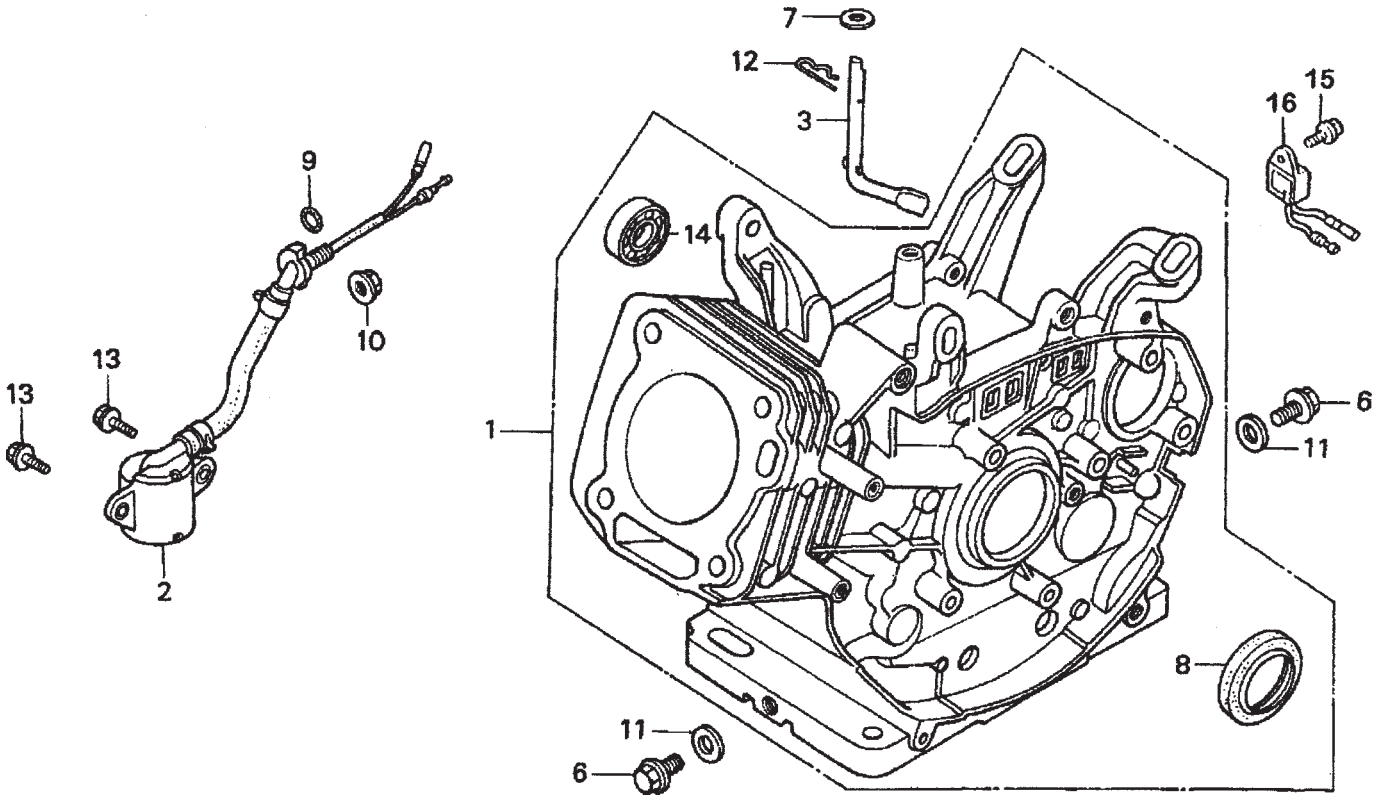

# HONDA GX240K1QA2 ENGINE — CYLINDER BARREL ASSY.

## CYLINDER BARREL ASSY.

<u>NO.</u>	<u>PART NO.</u>	<u>PART NAME</u>	<u>QTY.</u>	<u>REMARKS</u>
1	12000ZE2834	CYLINDER ASSY., BALANCER + OIL ALERT	1	INCLUDES ITEMS W/*
2	15510ZE2043	SWITCH ASSY., OIL LEVEL	1	
3	16541ZE2010	SHAFT, GOVERNOR ARM	1	
6	90131896650	BOLT, DRAIN PLUG	2	
7	90446KE1000	WASHER 8.2 X17X0.8	1	
8*	91201890003	OIL SEAL 30X46X8	1	
9	91353671003	O-RING 14MM ARAI	1	
10	9405010000	NUT FLANGE 10MM	1	
11	031112230	WASHER, DRAIN PLUG 12MM	2	
12	9425110000	PIN, LOCK 10MM	1	
13	957010601200	BOLT, FLANGE 6X12	2	
14*	961006202000	BEARING, RADIAL BALL 6202	1	
15	90013883000	BOLT, FLANGE 6X12 CT200	1	
16	34150ZH7003	ALERT UNIT, OIL	1	





# HONDA GX240K1QA2 ENGINE — CYLINDER HEAD ASSY.

## CYLINDER HEAD ASSY.

<u>NO.</u>	<u>PART NO.</u>	<u>PART NAME</u>	<u>QTY.</u>	<u>REMARKS</u>
1	12200ZH9000	CYLINDER HEAD COMP. ....	1	INCLUDES ITEMS W/*
2*	12204ZE2306	GUIDE, VALVE, OS, OPTIONAL	1	
3*	12205ZE2305	GUIDE, EX. VALVE, OS, OPTIONAL	1	
4*	12216ZE2300	CLIP, VALVE GUIDE	1	
5	12251ZE2800	GASKET, CYLINDER HEAD	1	
6	12310ZE2020	COVER COMP., HEAD	1	
7	12391ZE2020	GASKET, CYLINDER HEAD COVER	1	
8	14775ZE2010	SEAT, VALVE SPRING	1	
10	90014ZE2000	BOLT, HEAD COVER	1	
11	90042ZE2000	BOLT, STUD 8X123	2	
12	92900080320E	BOLT, STUD 8X47	2	
13	90441ZE2010	WASHER COMP., HEAD COVER	1	
14	9430112200	PIN A, DOWEL 12X20	2	
15	950051100130M	BULK HOSE, VACUUM 11X1000, 11X100	1	
16	957011008000	BOLT, FLANGE 10X80	4	
17	9807956846	SPARK PLUG, BPR6ES, NGK	1	
17	9807956855	SPARK PLUG, W20EPR-U, DENSO	1	

# HONDA GX240K1QA2 ENGINE — FAN COVER ASSY.

FAN COVER ASSY.

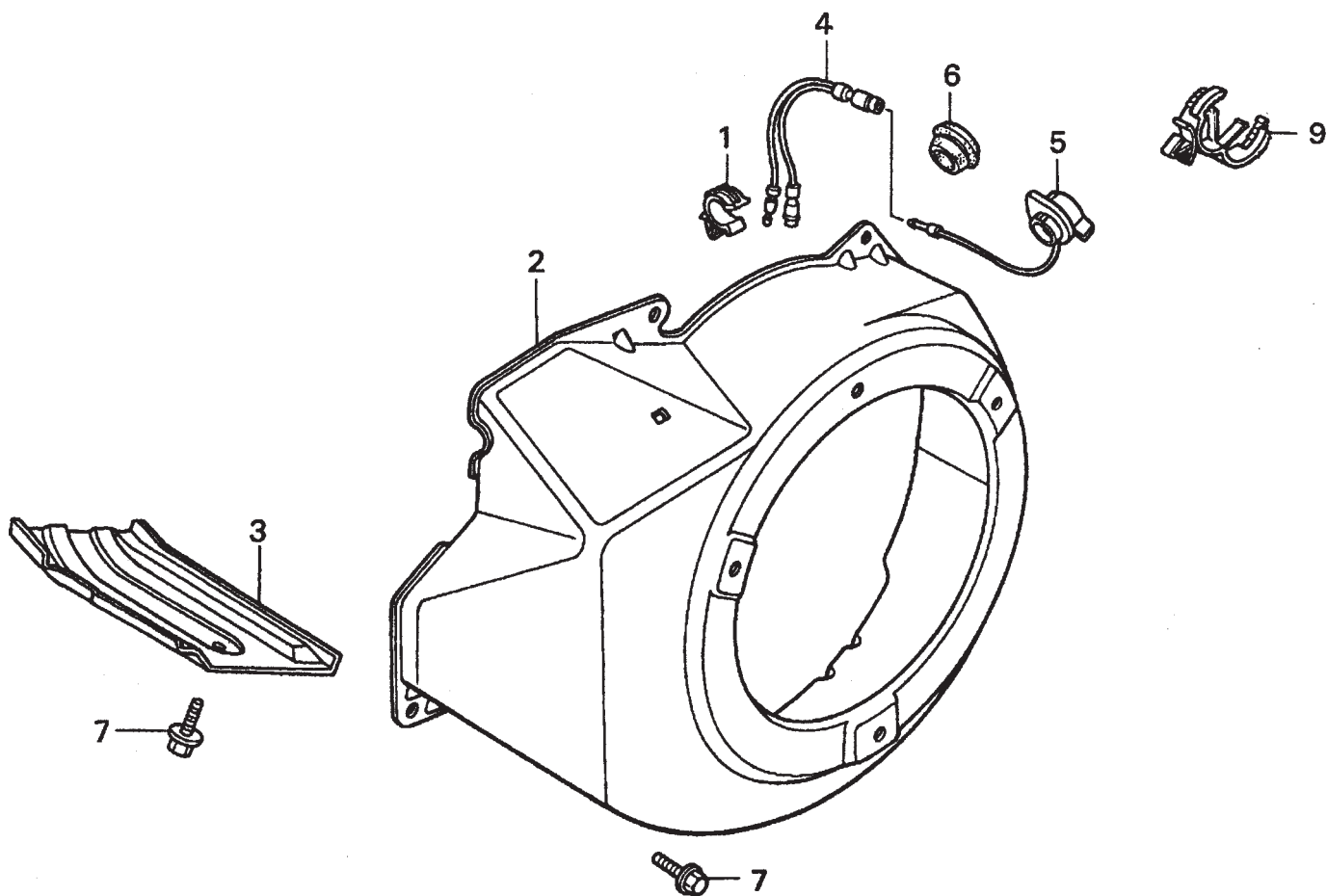

## HONDA GX240K1QA2 ENGINE — FAN COVER ASSY.

FAN COVER ASSY.

<u>NO.</u>	<u>PART NO.</u>	<u>PART NAME</u>	<u>QTY.</u>	<u>REMARKS</u>
1	16731ZE2003	CLIP, TUBE	1	
2	19610ZE2010ZC	COVER COMP., FAN *NH1* BLACK	1	
3	19631ZE2D00	SHROUD	1	
4	32197ZH8003	SUB-HARNESS	1	
5	36100ZE1015	SWITCH ASSY., ENGINE STOP	1	
7	90013883000	BOLT, FLANGE 6X12, CT200	6	
9	90684ZA0601	CLIP, WIRE HARNESS	1	

# HONDA GX240K1QA2 ENGINE — FLYWHEEL ASSY.

FLYWHEEL ASSY.

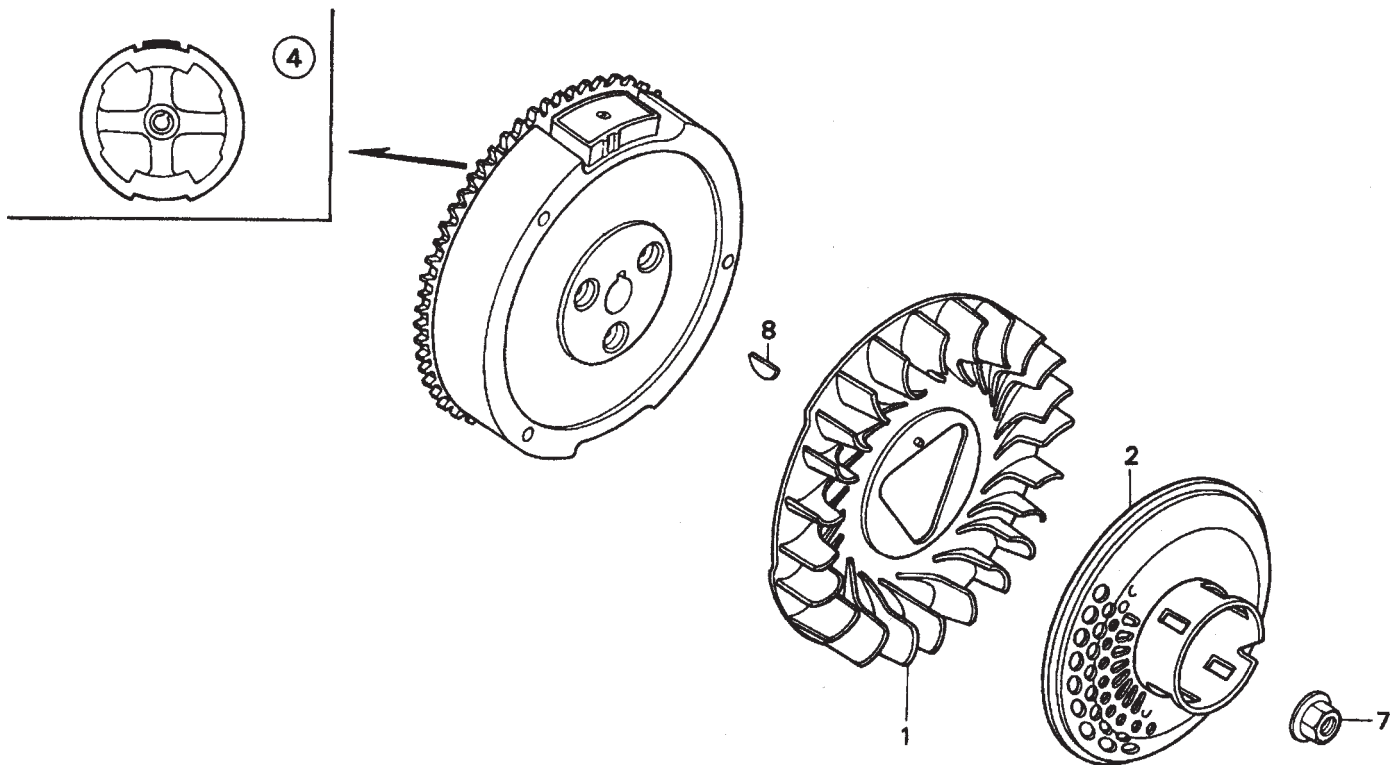

## HONDA GX240K1QA2 ENGINE — FLYWHEEL ASSY.

FLYWHEEL ASSY.

<u>NO.</u>	<u>PART NO.</u>	<u>PART NAME</u>	<u>QTY.</u>	<u>REMARKS</u>
1	19511ZE2000	FAN, COOLING	1	
2	28450ZE2W11	PULLEY COMP., STARTER, SCREEN GRID	1	
4	31100ZE2010	FLYWHEEL COMP.	1	
7	90201ZE3V00	NUT, SPECIAL 16MM	1	
8	90741ZE2000	KEY, SPECIAL WOODRUFF 25X18	1	

# HONDA GX240K1QA2 ENGINE — MUFFLER ASSY.

MUFFLER ASSY.

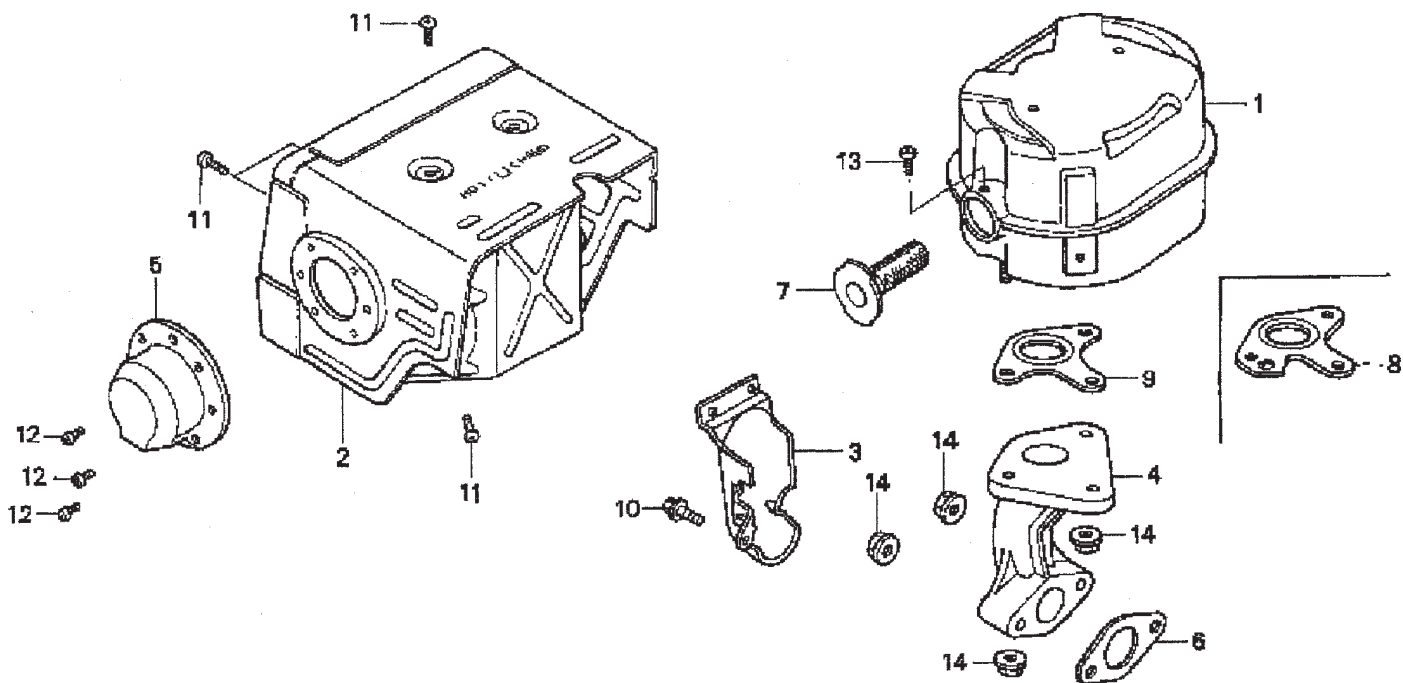

## HONDA GX240K1QA2 ENGINE — MUFFLER ASSY.

### MUFFLER ASSY.

<u>NO.</u>	<u>PART NO.</u>	<u>PART NAME</u>	<u>QTY.</u>	<u>REMARKS</u>
1	18310ZE2W00	MUFFLER	1	
2	18320ZE2W01	PROTECTOR, MUFFLER	1	
3	18323ZE2W00	PROTECTOR, EX. PIPE	1	
4	18330ZE2W00	PIPE, EX.	1	
5	18331ZE2810	CAP, MUFFLER	1	
6	18333ZK6Y00	GASKET, EX. PIPE	1	
7	18355ZE2010	ARRESTER, SPARK	1	
8	18381ZE2W10	GASKET, MUFFLER (ARRESTER)	1	
9	18381ZE2800	GASKET, MUFFLER	1	
10	90013883000	BOLT, FLANGE (6 X 12) (CT200)	1	
11	90050ZE1000	SCREW, TAPPING (5 X 8)	6	
12	90055ZE1000	SCREW, TAPPING (4 X 6)	3	
13	90050ZE1000	SCREW, TAPPING (5 X 8) (OPTIONAL)	1	
14	9405008000	NUT, FLANGE (8MM)	5	



# HONDA GX240K1QA2 ENGINE — FUEL TANK ASSY.

FUEL TANK ASSY.

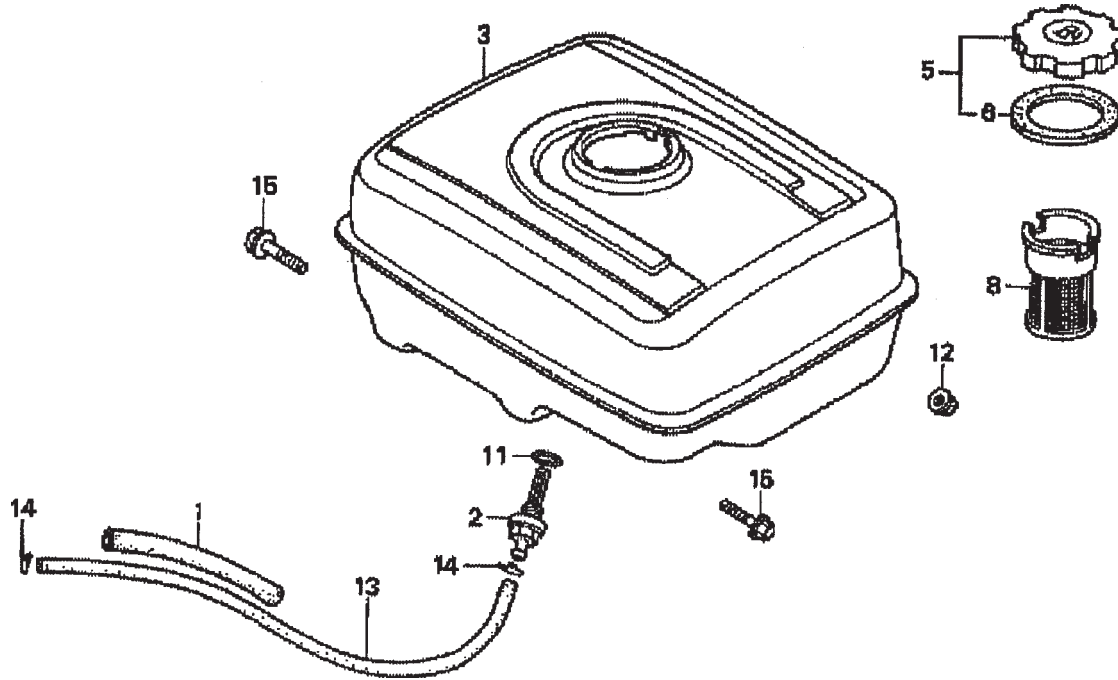

## HONDA GX240K1QA2 ENGINE — FUEL TANK ASSY.

### FUEL TANK ASSY.

<u>NO.</u>	<u>PART NO.</u>	<u>PART NAME</u>	<u>QTY.</u>	<u>REMARKS</u>
1	16854ZH8000	RUBBER SUPPORTER 107MM	1	
2	16955ZE1000	JOINT, FUEL TANK	1	
3	17510ZE2010ZD	TANK COMP., FUEL *NH1*, BLACK	1	
5	17620ZH7023	CAP COMP., FUEL FILLER .....	1	INCLUDES ITEMS W/*
6*	17631ZH7003	GASKET, FUEL FILLER CAP	1	
8	17672ZE2W01	FILTER, FUEL	1	
11	91353671003	O-RING 14MM, ARAI	1	
12	9405008000	NUT, FLANGE 8MM	2	
13	950014500360M	BULK HOSE, FUEL 4.5X3000, 4.5X222	1	
14	9500202080	CLIP, TUBE, B8	2	
15	957010802500	BOLT, FLANGE 8X25	2	

# HONDA GX240K1QA2 ENGINE — IGNITION ASSY.

IGNITION COIL ASSY.

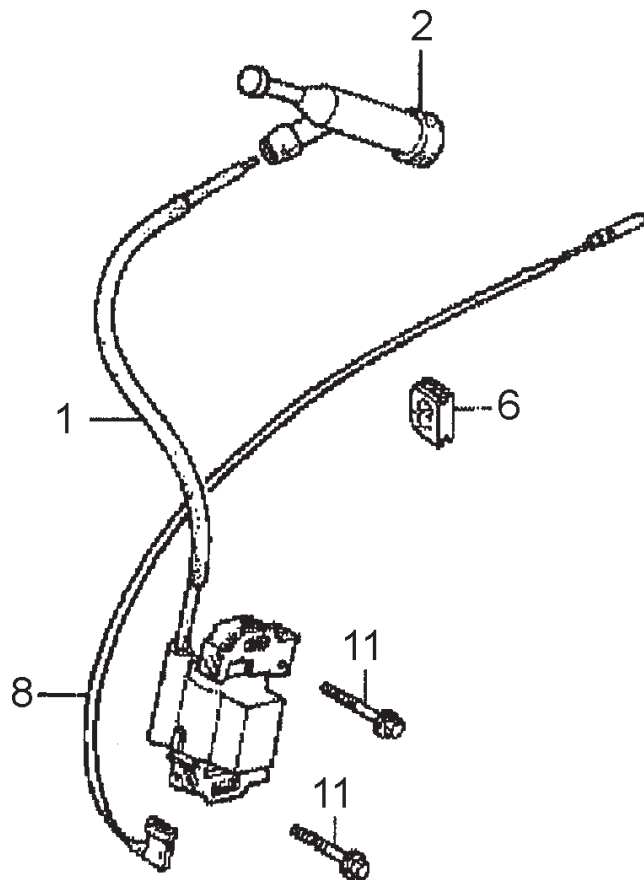

# HONDA GX240K1QA2 ENGINE — IGNITION ASSY.

## IGNITION COIL ASSY.

<u>NO.</u>	<u>PART NO.</u>	<u>PART NAME</u>	<u>QTY.</u>	<u>REMARKS</u>
1	30500ZF6W02	COIL ASSY., IGNITION	1	
2	30700ZE1013	CAP ASSY., NOISE SUPPRESSOR	1	
6	31512ZE2000	GROMMET, WIRE	1	
8	36101ZE1010	WIRE, STOP SWITCH 370MM	1	
11	90015883000	BOLT, FLANGE 6X28	2	

# HONDA GX240K1QA2 ENGINE — PISTON ASSY.

PISTON ASSY.

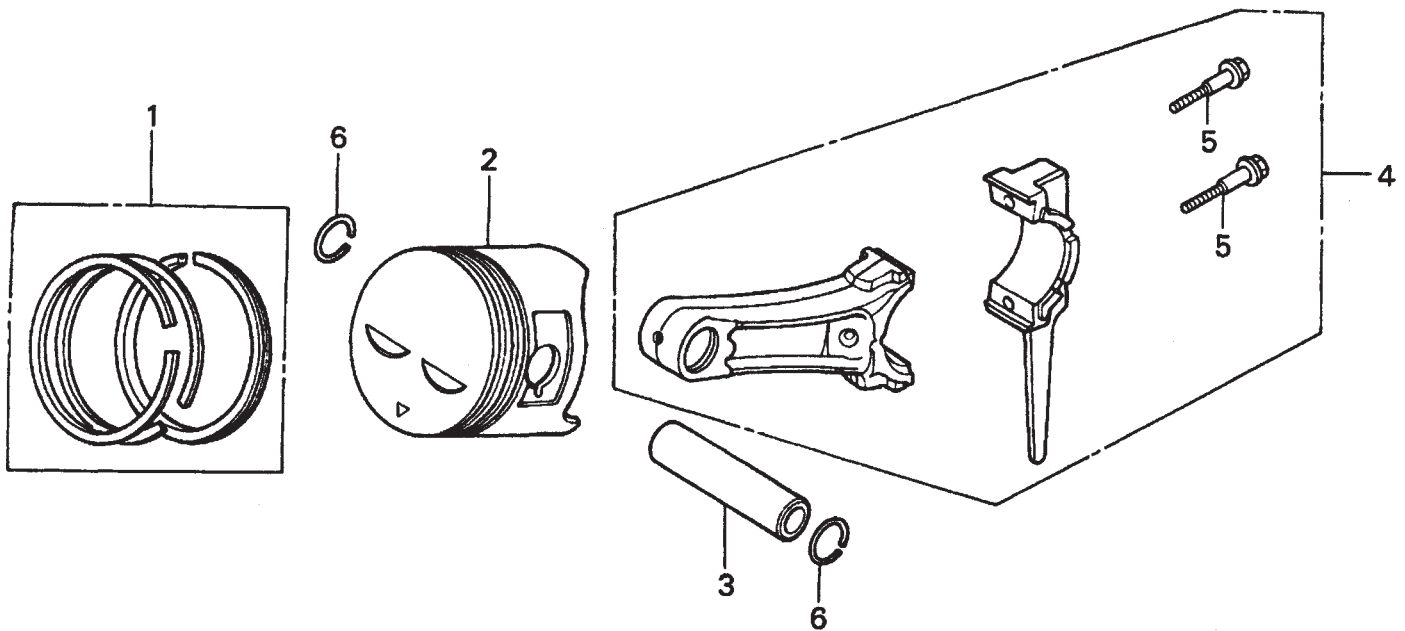

# HONDA GX240K1QA2 ENGINE — PISTON ASSY.

PISTON ASSY.

<u>NO.</u>	<u>PART NO.</u>	<u>PART NAME</u>	<u>QTY.</u>	<u>REMARKS</u>
1	13010ZE2013	RING SET, PISTON, STD.	1	
1	13011ZE2013	RING SET, PISTON, OS 0.25, OPTIONAL	1	
1	13012ZE2013	RING SET, PISTON, OS 0.50, OPTIONAL	1	
1	13013ZE2013	RING SET, PISTON, 0.75, OPTIONAL	1	
2	13101ZE2W00	PISTON, STANDARD	1	
2	13102ZE2W00	PISTON, OS 0.25, OPTIONAL	1	
2	13103ZE2W00	PISTON, OS 0.50, OPTIONAL	1	
2	13104ZE2W00	PISTON, 0.75, OPTIONAL	1	
3	13111ZE2000	PIN, PISTON	1	
4	13200ZE2000	ROD ASSY., CONNECTING STANDARD .....	1	INCLUDES ITEMS W/*
4	13200ZE2305	ROD ASSY., CONNECTING, US 0.25, OPT.	1	
5*	90001ZE8000	BOLT, CONNECTING ROD	2	
6	90551ZE1000	CLIP, PISTON PIN 18MM	2	

# HONDA GX240K1QA2 ENGINE — RECOIL STARTER ASSY.

RECOIL STARTER ASSY.

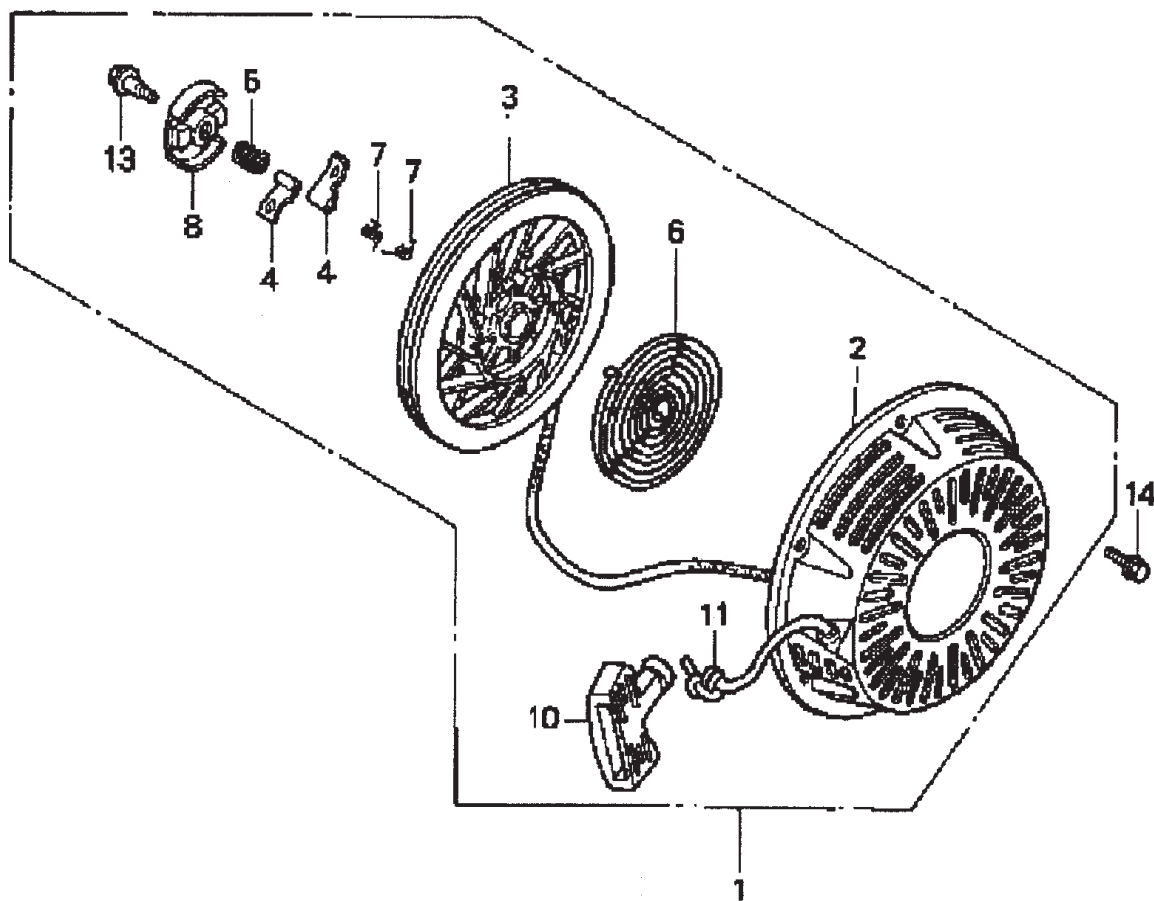

# HONDA GX240K1QA2 ENGINE — RECOIL STARTER ASSY.

## RECOIL STARTER ASSY.

<u>NO.</u>	<u>PART NO.</u>	<u>PART NAME</u>	<u>QTY.</u>	<u>REMARKS</u>
1	28400ZE2W01ZB	STARTER ASSY., RECOIL *NH1*, BLK .....	1 .....	INCLUDES ITEMS W/*
2*	28410ZE2W01ZB	CASE COMP., RECOIL STARTER *NH1*, BLK	1	
3*	28421ZE2W01	PULLEY, RECOIL STARTER	1	
4*	28422ZE2W01	RATCHET, STARTER	2	
5*	28441ZE2W01	SPRING, FRICTION	1	
6*	28442ZE2W01	SPRING, STARTER RETURN	1	
7*	28443ZE2W01	SPRING RATCHET	2	
8*	28444ZE2W01	RETAINER, SPRING	1	
10*	28461ZE2W02	GRIP, STARTER	1	
11*	28462ZE2W11	ROPE, RECOIL STARTER	1	
13*	90004ZE2W01	SCREW, CENTER	1	
14	90008ZE2003	BOLT, FLANGE 6X10	3	



# HONDA GX240K1QA2 ENGINE — LABEL ASSY.

LABEL ASSY.

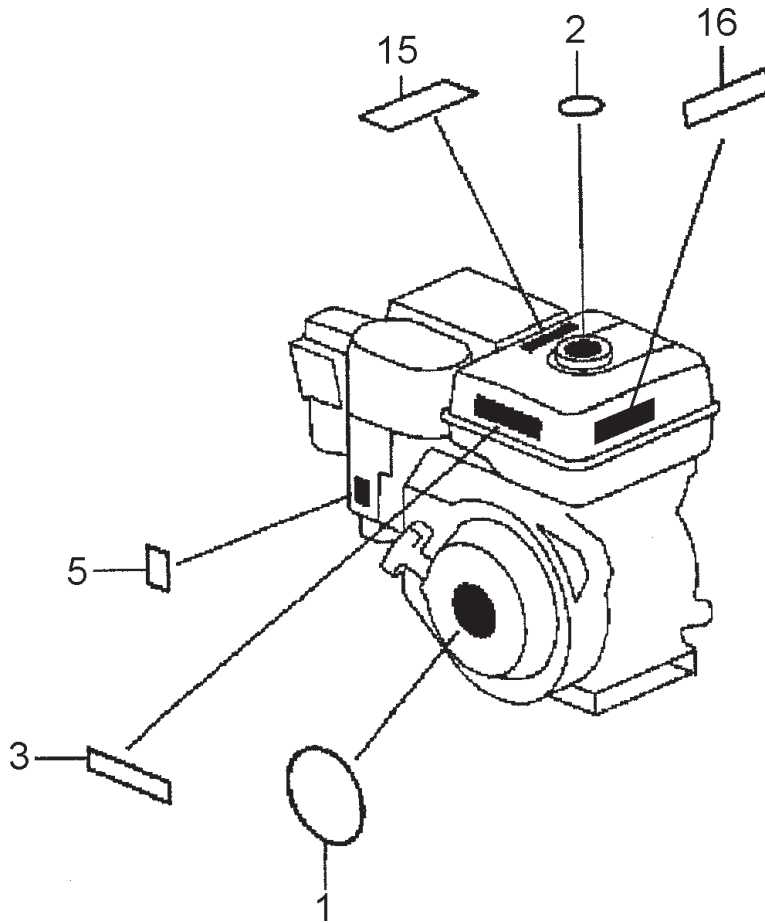

## HONDA GX240K1QA2 ENGINE — LABEL ASSY.

### LABELS ASSY.

<u>NO.</u>	<u>PART NO.</u>	<u>PART NAME</u>	<u>QTY.</u>	<u>REMARKS</u>
1	87521ZE2W01	EMBLEM, INTERNAL	1	
2	87522ZE1810	MARK, CAUTION, EXTERNAL	1	
3	87522ZH9000	LABEL, CAUTION	1	
5	87528ZE2810	MARK, CHOKE, EXTERNAL	1	
15	87586ZH7W00	LABEL, FUEL CAUTION	1	
16	87532ZH8810	MARK, OIL ALERT	1	